



QUICKSWITCH® PRODUCTS
HIGH-SPEED CMOS
24-BIT BUS-EXCHANGE SWITCH

IDTQS316212

FEATURES:

- Enhanced N channel FET with no inherent diode to Vcc
- Low propagation delay
- TTL-compatible input and output levels
- Undershoot clamp diodes on all switch and control inputs
- Available in TSSOP package

APPLICATIONS:

- Resource sharing
- Crossbar switching
- Hot-docking
- Voltage translation (5V to 3.3V)

DESCRIPTION:

The QS316212 provides a set of 24 high-speed CMOS TTL-compatible bus-exchange switches. The low ON resistance of the QS316212 allows inputs to be connected to outputs without adding propagation delay and without generating additional ground bounce noise. The device operates as a 24-bit bus switch or a 12-bit bus exchanger, which provides data exchanging between the four signal ports through the data-select (S0-S2) terminals.

The QS316212 is characterized for operation at -40°C to +85°C.

FUNCTIONAL BLOCK DIAGRAM

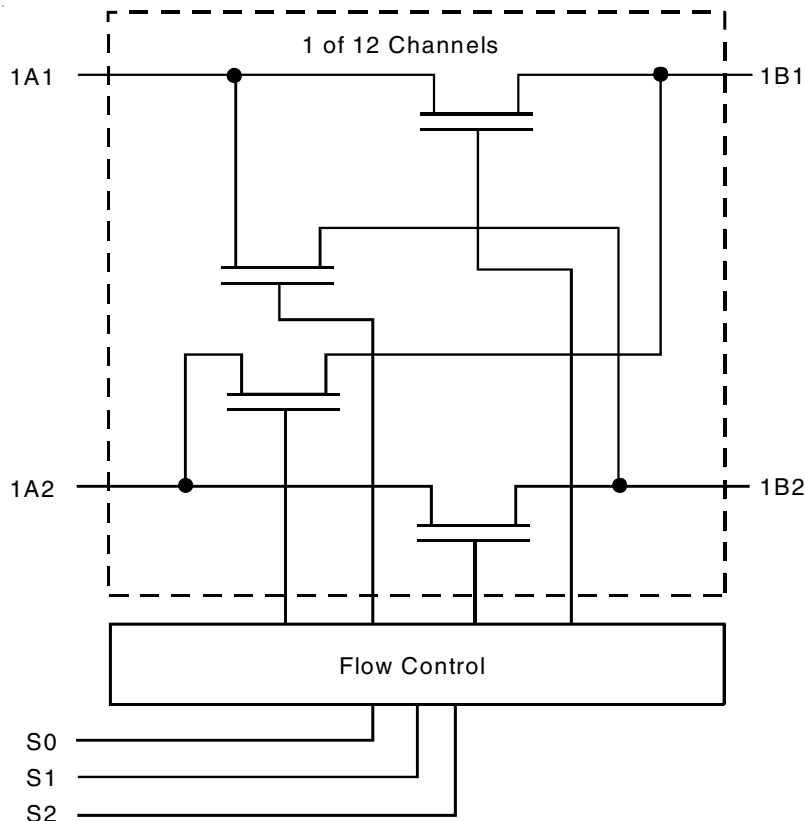

The IDT logo is a registered trademark of Integrated Device Technology, Inc.

PIN CONFIGURATION

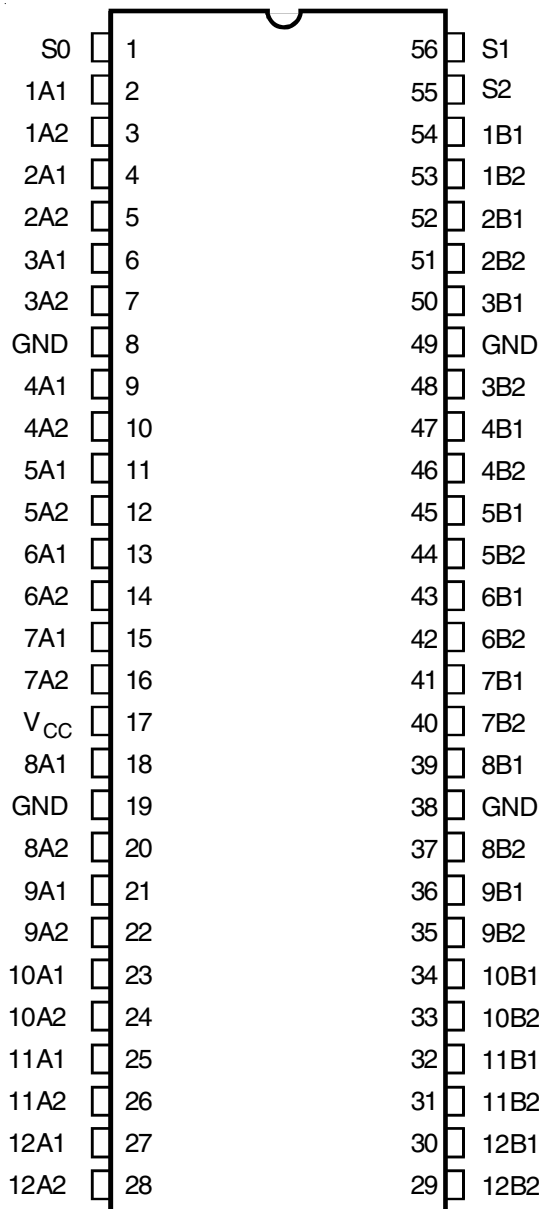

TSSOP
TOP VIEW

ABSOLUTE MAXIMUM RATINGS⁽¹⁾

| Symbol | Description | Max | Unit | |
|----------------------|---|-------------|------|---|
| VTERM ⁽²⁾ | Supply Voltage to Ground | -0.5 to +7 | V | |
| VTERM ⁽³⁾ | DC Switch Voltage V _S | -0.5 to +7 | V | |
| VTERM ⁽³⁾ | DC Input Voltage V _{IN} | -0.5 to +7 | V | |
| V _{AC} | AC Input Voltage (pulse width ≤20ns) | -3 | V | |
| I _{OUT} | DC Output Current | 120 | mA | |
| P _{MAX} | Maximum Power Dissipation (T _A = 85°C) | SSOP | 0.93 | W |
| | | TSSOP | 0.77 | |
| T _{STG} | Storage Temperature | -65 to +150 | °C | |

NOTES:

- Stresses greater than those listed under ABSOLUTE MAXIMUM RATINGS may cause permanent damage to the device. This is a stress rating only and functional operation of the device at these or any other conditions above those indicated in the operational sections of this specification is not implied. Exposure to absolute maximum rating conditions for extended periods may affect reliability.
- V_{CC} terminals.
- All terminals except V_{CC}.

CAPACITANCE (T_A = +25°C, f = 1MHz, V_{IN} = 0V, V_{OUT} = 0V)

| Pins | Typ. | Max. ⁽¹⁾ | Unit |
|-----------------------------------|------|---------------------|------|
| Control Inputs | 4 | 5 | pF |
| Quickswitch Channels (Switch OFF) | 7.5 | 9 | pF |

NOTE:

- This parameter is guaranteed but not production tested.

PIN DESCRIPTION

| Pin Names | I/O | Description |
|------------|-----|-------------|
| 1Ax - 12Ax | I/O | Bus A |
| 1Bx - 12Bx | I/O | Bus B |
| S0 - S2 | I | Data Select |

FUNCTION TABLE⁽¹⁾

| S2 | S1 | S0 | xA1 | xA2 | Function |
|----|----|----|-----|-----|------------------------|
| L | L | L | Z | Z | Disconnect |
| L | L | H | xB1 | Z | xA1 to xB1 |
| L | H | L | xB2 | Z | xA1 to xB2 |
| L | H | H | Z | xB1 | xA2 to xB1 |
| H | L | L | Z | xB2 | xA2 to xB2 |
| H | L | H | Z | Z | Disconnect |
| H | H | L | xB1 | xB2 | xA1 to xB1, xA2 to xB2 |
| H | H | H | xB2 | xB1 | xA1 to xB2, xA2 to xB1 |

NOTE:

- H = HIGH Voltage Level
L = LOW Voltage Level
Z = High-Impedance

DC ELECTRICAL CHARACTERISTICS OVER OPERATING RANGE

Following Conditions Apply Unless Otherwise Specified:

Industrial: $T_A = -40^{\circ}\text{C}$ to $+85^{\circ}\text{C}$, $V_{CC} = 5\text{V} \pm 10\%$

| Symbol | Parameter | Test Conditions | Min. | Typ. ⁽¹⁾ | Max. | Unit |
|----------|--|--|------|---------------------|---------|---------------|
| V_{IH} | Input HIGH Voltage | Guaranteed Logic HIGH for Control Inputs | 2 | — | — | V |
| V_{IL} | Input LOW Voltage | Guaranteed Logic LOW for Control Inputs | — | — | 0.8 | V |
| I_{IN} | Input Leakage Current (Control Inputs) | $0\text{V} \leq V_{IN} \leq V_{CC}$ | — | — | ± 1 | μA |
| I_{OZ} | Off-State Current (Hi-Z) | $0\text{V} \leq V_{OUT} \leq V_{CC}$, Switches OFF | — | — | ± 1 | μA |
| RON | Switch ON Resistance ⁽²⁾ | $V_{CC} = \text{Min.}$, $V_{IN} = 0\text{V}$, $I_{ON} = 30\text{mA}$ | — | 5 | 7 | Ω |
| | | $V_{CC} = \text{Min.}$, $V_{IN} = 2.4\text{V}$, $I_{ON} = 15\text{mA}$ | — | 10 | 12 | |
| V_P | Pass Voltage ⁽³⁾ | $V_{IN} = V_{CC} = 5\text{V}$, $I_{OUT} = -5\mu\text{A}$ | 3.7 | 4 | 4.2 | V |

NOTES:

1. Typical values are at $V_{CC} = 5\text{V}$ and $T_A = 25^{\circ}\text{C}$.
2. R_{ON} is guaranteed but not production tested.
3. Pass voltage is guaranteed but not production tested.

TYPICAL ON RESISTANCE vs V_{IN} AT $V_{CC} = 5\text{V}$

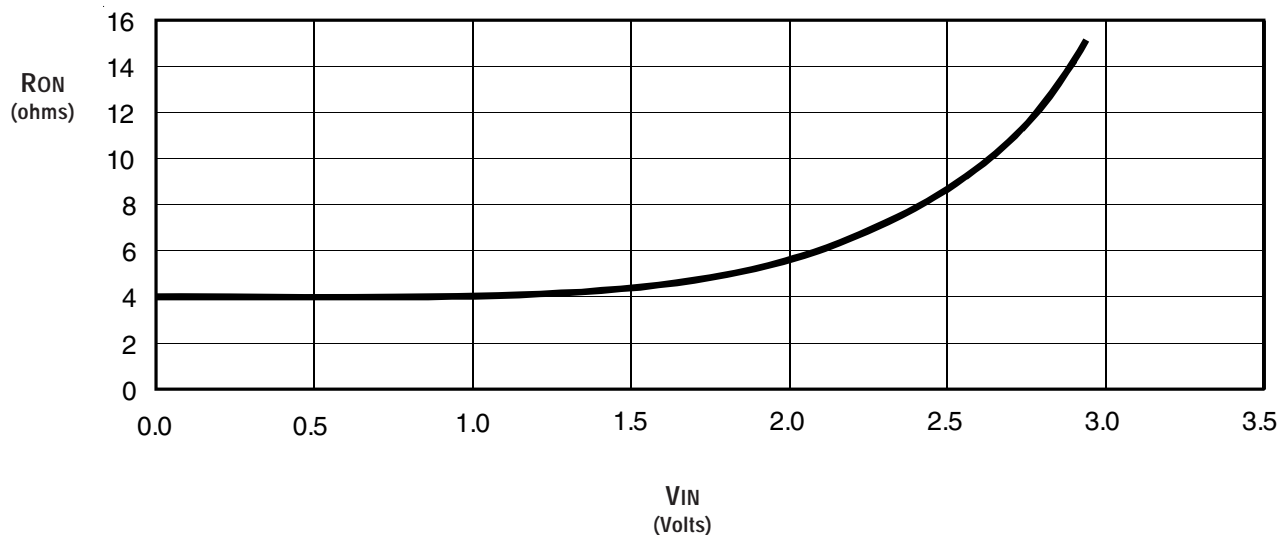

POWER SUPPLY CHARACTERISTICS

| Symbol | Parameter | Test Conditions ⁽¹⁾ | Max. | Unit |
|------------------|--|---|------|--------|
| I _{CCQ} | Quiescent Power Supply Current | V _{CC} = Max., V _{IN} = GND or V _{CC} , f = 0 | 3 | μA |
| ΔI _{CC} | Power Supply Current per Control Input HIGH ⁽²⁾ | V _{CC} = Max., V _{IN} = 3.4V, f = 0 | 2.5 | mA |
| I _{CCD} | Dynamic Power Supply Current per MHz ⁽³⁾ | V _{CC} = Max., A and B Pins Open, Control Inputs Toggling @ 50% Duty Cycle | 0.25 | mA/MHz |

NOTES:

- For conditions shown as Min. or Max., use the appropriate values specified under DC Electrical Characteristics.
- Per TTL-driven input (V_{IN} = 3.4V). A and B pins do not contribute to ΔI_{CC}.
- This current applies to the control inputs only and represents the current required to switch internal capacitance at the specified frequency. The A and B inputs generate no significant AC or DC currents as they transition. This parameter is guaranteed but not production tested.

SWITCHING CHARACTERISTICS OVER OPERATING RANGE

T_A = -40°C to +85°C, V_{CC} = 5V ± 10%

C_{LOAD} = 50pF, R_{LOAD} = 500Ω unless otherwise noted.

| Symbol | Parameter | Min. ⁽¹⁾ | Typ. | Max. | Unit |
|--------------------------------------|---|---------------------|------|---------------------|------|
| t _{PLH} t _{PHL} | Data Propagation Delay ⁽²⁾ xAx to xBx, xBx to xAx | — | — | 0.25 ⁽³⁾ | ns |
| t _{PZL} t _{PZH} | Switch Turn-On Delay Sx to xAx, xBx | 1.5 | — | 6.5 | ns |
| t _{PLZ} t _{PHZ} | Switch Turn-Off Delay ⁽²⁾ Sx to xAx, xBx | 1.5 | — | 6.2 | ns |

NOTES:

- Minimums are guaranteed but not production tested.
- This parameter is guaranteed but not production tested.
- The bus switch contributes no propagation delay other than the RC delay of the ON resistance of the switch and the load capacitance. The time constant for the switch alone is of the order of 0.25ns at C_L = 50pF. Since this time constant is much smaller than the rise and fall times of typical driving signals, it adds very little propagation delay to the system. Propagation delay of the bus switch, when used in a system, is determined by the driving circuit on the driving side of the switch and its interaction with the load on the driven side.

ORDERING INFORMATION

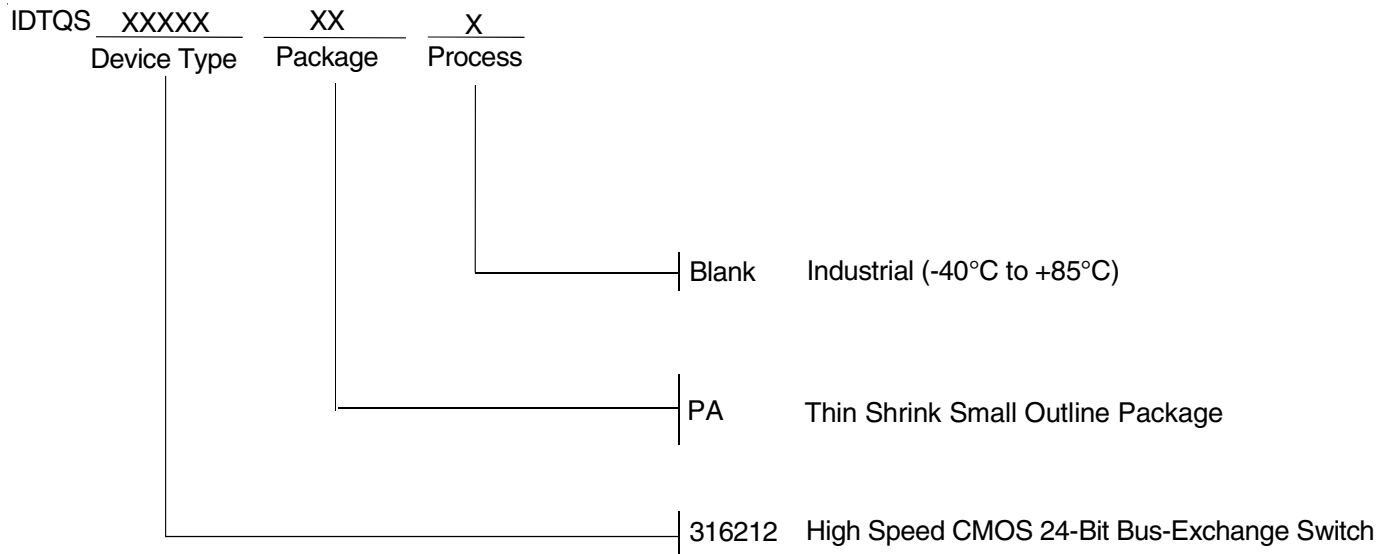

CORPORATE HEADQUARTERS
6024 Silver Creek Valley Road
San Jose, CA 95138

for SALES:
800-345-7015 or 408-284-8200
fax: 408-284-2775
www.idt.com

for Tech Support:
logichelp@idt.com