

12-Bit To 24-Bit Multiplexed D-Type Latch with 3-State Outputs

Product Features

- Designed for low voltage operation, V_{CC} from 1.65V to 3.6V
- Sub 2.0ns delays at 2.5V and 3.3V
- Dynamic Impedance Control on outputs, current drive $> \pm 24\text{mA}$ at 2.5V V_{CC}
- Patented noise reduction circuit
- I/O Tolerant to 3.6V, Inputs and Outputs for mixed voltage systems
- Supports live insertion
- Industrial operation at -40°C to $+85^{\circ}\text{C}$
- Available Packages:
 - 48-pin 240 mil wide plastic TSSOP (A48)
 - 48-pin 173 mil wide plastic TVSOP (K48)

Product Description

Pericom Semiconductor's PI74AVC series of logic circuits are produced using the Company's advanced 0.35 micron CMOS technology, achieving industry leading speed.

The 12-bit to 24-bit multiplexed D-type latch is used in applications where two separate datapaths must be multiplexed onto, or demultiplexed from, a single data path.

Typical applications include multiplexing and/or demultiplexing address and data information in microprocessor or bus-interface applications. This device is also useful in memory-interleaving applications.

Three 12-bit I/O ports (A1-A12, 1B1-1B12, and 2B1-2B12) are available for address and/or data transfer. The output-enable ($\overline{\text{OE1B}}$, $\overline{\text{OE2B}}$, and $\overline{\text{OEA}}$) inputs control the bus transceiver functions. The $\overline{\text{OE1B}}$ and $\overline{\text{OE2B}}$ control signals also allow bank control in the A-to-B direction.

Address and/or data information can be stored using the internal storage latches. The latch-enable (LE1B, LE2B, LEA1B, and LEA2B) inputs are used to control data storage. When the latch-enable input is HIGH, the latch is transparent. When the latch-enable input goes LOW, the data present at the inputs is latched and remains latched until the latch-enable input is returned HIGH.

To ensure the high-impedance state during power up or power down, $\overline{\text{OE}}$ should be tied to V_{CC} through a pullup resistor, the minimum value of the resistor is determined by the current-sinking capability of the driver.

Active bus-hold circuitry is provided to hold unused or floating data inputs at a valid logic level.

The PI74AVCH16260 has "Bus Hold" which retains the data input's last state whenever the data input goes to high-impedance preventing "floating" inputs and eliminating the need for pullup/down resistors.

Logic Block Diagram

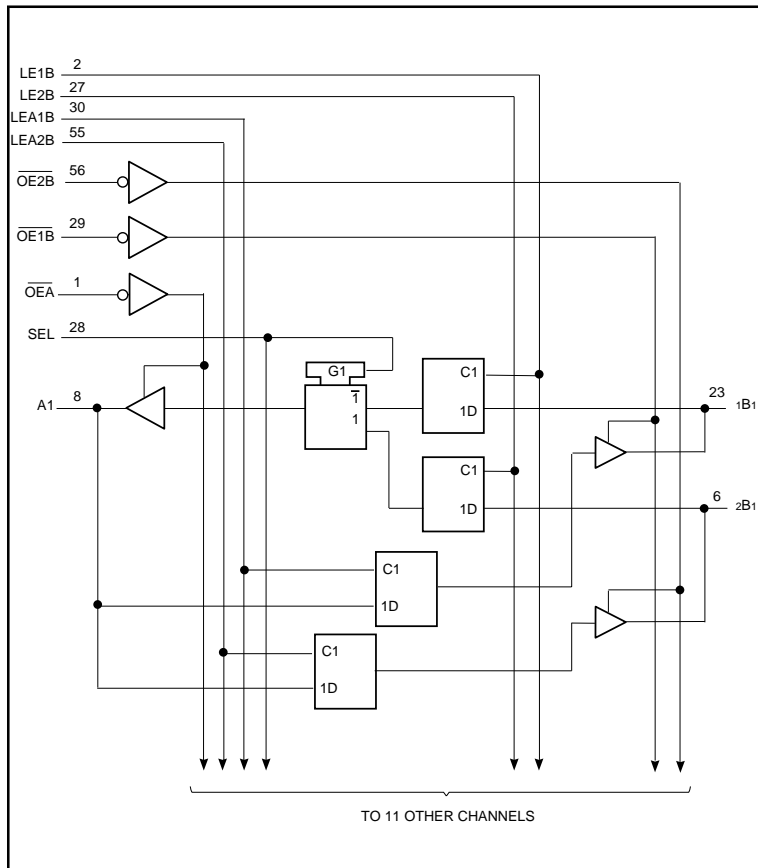

Product Pin Description

Pin Name	Description
\overline{OE}	Output Enable Input (Active LOW)
SEL	Select
LE	Latch Enable
A,1B,2B	Data Inputs
A,1B,2B	3-State Outputs
GND	Ground
Vcc	Power

Product Pin Configuration

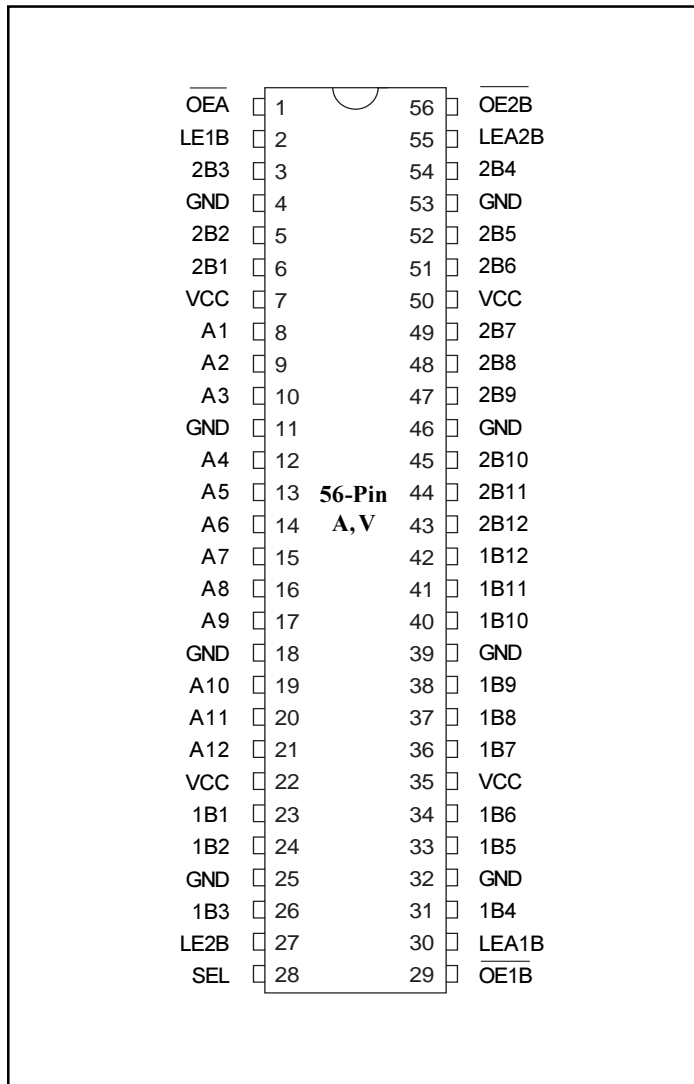

Truth Tables⁽¹⁾

B to A ($\overline{OE}B=H$)

Inputs						Output A
1B	2B	SEL	LE1B	LE2B	$\overline{OE}A$	
H	X	H	H	X	L	H
L	X	H	H	X	L	L
X	X	H	L	X	L	A0
X	H	L	X	H	L	H
X	L	L	X	H	L	L
X	X	L	X	L	L	A0
X	X	X	X	X	H	Z

A to B ($\overline{OE}A=H$)

INPUTS					OUTPUTS	
A	LEA1B	LEA2B	$\overline{OE}1B$	$\overline{OE}2B$	1B	2B
H	H	H	L	L	H	H
L	H	H	L	L	L	L
H	H	L	L	L	H	2B0
L	H	L	L	L	L	2B0
H	L	H	L	L	1B0	H
L	L	H	L	L	1B0	L
X	L	L	L	L	1B0	2B0
X	X	X	H	H	Z	Z
X	X	X	L	H	Active	Z
X	X	X	H	L	Z	Active
X	X	X	L	L	Active	Active

Note:

1. H = High Signal Level
- L = Low Signal Level
- X = Irrelevant
- Z = High Impedance



Maximum Ratings

(Above which the useful life may be impaired. For user guidelines, not tested.)

Storage Temperature	-65°C to +150°C
Ambient Temperature with Power Applied	-40°C to +85°C
Input Voltage Range, V _{IN}	-0.5V to V _{CC} +0.5V
Output Voltage Range, V _{OUT}	-0.5V to V _{CC} +0.5V
DC Input Voltage	-0.5V to +5.0V
DC Output Current	100 mA
Power Dissipation	1.0W

Note:

Stresses greater than those listed under MAXIMUM RATINGS may cause permanent damage to the device. This is a stress rating only and functional operation of the device at these or any other conditions above those indicated in the operational sections of this specification is not implied. Exposure to absolute maximum rating conditions for extended periods may affect reliability.

DC Electrical Characteristics (Over the Operating Range, T_A = -40°C to +85°C, V_{CC} = 3.3V ± 10%)

Parameters	Description	Test Conditions ⁽¹⁾	Min.	Typ. ⁽²⁾	Max.	Units
V _{CC}	Supply Voltage		2.3		3.6	
V _{IH} ⁽³⁾	Input HIGH Voltage	V _{CC} = 2.3V to 2.7V	1.7			
		V _{CC} = 2.7V to 3.6V	2.0			
V _{IL} ⁽³⁾	Input LOW Voltage	V _{CC} = 2.3V to 2.7V			0.7	
		V _{CC} = 2.7V to 3.6V			0.8	
V _{IN} ⁽³⁾	Input Voltage		0		V _{CC}	
V _{OUT} ⁽³⁾	Output Voltage		0		V _{CC}	
V _{OH}	Output HIGH Voltage	I _{OH} = -100µA, V _{CC} = Min. to Max.	V _{CC} -0.2			
		V _{IH} = 1.7V, I _{OH} = -6mA, V _{CC} = 2.3V	2.0			
		V _{IH} = 1.7V, I _{OH} = -12mA, V _{CC} = 2.3V	1.7			
		V _{IH} = 2.0V, I _{OH} = -12mA, V _{CC} = 2.7V	2.2			
		V _{IH} = 2.0V, I _{OH} = -12mA, V _{CC} = 3.0V	2.4			
		V _{IH} = 2.0V, I _{OH} = -24mA, V _{CC} = 3.0V	2.0			
V _{OL}	Output LOW Voltage	I _{OL} = 100µA, V _{IL} = Min. to Max.			0.2	
		V _{IL} = 0.7V, I _{OL} = 6mA, V _{CC} = 2.3V			0.4	
		V _{IL} = 0.7V, I _{OL} = 12mA, V _{CC} = 2.3V			0.7	
		V _{IL} = 0.8V, I _{OL} = 12mA, V _{CC} = 2.7V			0.4	
		V _{IL} = 0.8V, I _{OL} = 24mA, V _{CC} = 3.0V			0.55	
I _{OH} ⁽³⁾	Output HIGH Current	V _{CC} = 2.3V			-12	
		V _{CC} = 2.7V			-12	
		V _{CC} = 3.0V			-24	
I _{OL} ⁽³⁾	Output LOW Current	V _{CC} = 2.3V			12	
		V _{CC} = 2.7V			12	
		V _{CC} = 3.0V			24	

DC Electrical Characteristics-Continued (Over the Operating Range, $T_A = -40^{\circ}\text{C}$ to $+85^{\circ}\text{C}$, $V_{CC} = 3.3\text{V} \pm 10\%$)

Parameters	Description	Test Conditions ⁽¹⁾	Min.	Typ. ⁽²⁾	Max.	Units
I_{IN}	Input Current	$V_{IN} = V_{CC}$ or GND, $V_{CC} = 3.6\text{V}$			± 5	μA
$I_{IN (HOLD)}$	Input Hold Current	$V_{IN} = 0.7\text{V}$, $V_{CC} = 2.3\text{V}$	45			
		$V_{IN} = 1.7\text{V}$, $V_{CC} = 2.3\text{V}$	-45			
		$V_{IN} = 0.8\text{V}$, $V_{CC} = 3.0\text{V}$	75			
		$V_{IN} = 2.0\text{V}$, $V_{CC} = 3.0\text{V}$	-75			
		$V_{IN} = 0$ to 3.6V , $V_{CC} = 3.6\text{V}$			± 500	
I_{OZ}	Output Current (3-STATE Outputs)	$V_{OUT} = V_{CC}$ or GND, $V_{CC} = 3.6\text{V}$			± 10	pF
I_{CC}	Supply Current	$V_{CC} = 3.6\text{V}$, $I_{OUT} = 0\mu\text{A}$, $V_{IN} = \text{GND}$ or V_{CC}			40	
ΔI_{CC}	Supply Current per Input @ TTL HIGH	$V_{CC} = 3.0\text{V}$ to 3.6V One Input at $V_{CC} - 0.6\text{V}$ Other Inputs at V_{CC} or GND			750	
C_I	Control Inputs	$V_{IN} = V_{CC}$ or GND, $V_{CC} = 3.3\text{V}$		3.5		
C_O	Outputs	$V_O = V_{CC}$ or GND, $V_{CC} = 3.3\text{V}$		9		

Notes:

- For conditions shown as Max. or Min., use appropriate value specified under Electrical Characteristics for the applicable device type.
- Typical values are at $V_{CC} = 3.3\text{V}$, $+25^{\circ}\text{C}$ ambient and maximum loading.
- Unused Control Inputs must be held HIGH or LOW to prevent them from floating.

Timing Requirements over Operating Range

Parameters	Description	$V_{CC} = 2.5\text{V} \pm 0.2\text{V}$		$V_{CC} = 2.7\text{V}$		$V_{CC} = 3.3\text{V} \pm 0.3\text{V}$		Units
		Min.	Max.	Min.	Max.	Min.	Max.	
t_W	Pulse duration, LE1B, LE2B, LEA1B, or LEA2B High	3.3		3.3		3.3		ns
t_{SU}	Setup time, data before LE1B, LE2B, LEA1B, or LEA2B	1.4		1.1		1.1		
t_H	Hold time, data after LE1B, LE2B, LEA1B or LEA2B	1.6		1.9		1.5		
$\Delta t/\Delta V^{(1)}$	Input Transition Rise or Fall	0	10	0	10	0	10	ns/V

Note:

- Unused control inputs must be held HIGH or LOW to prevent them from floating.

Switching Characteristics over Operating Range⁽¹⁾

Parameters	From (INPUT)	To (OUTPUT)	V _{CC} = 2.5V ± 0.2V		V _{CC} = 2.7V		V _{CC} = 3.3V ± 0.3V		Units
			Min. ⁽²⁾	Max.	Min. ⁽²⁾	Max.	Min. ⁽²⁾	Max. ⁽²⁾	
t _{PD}	A or B	B or A	1.2	6.0		5.1	1.2	4.3	ns
	LE	A or B	1.0	6.2		5.2	1.0	4.4	
	SEL	A	1.2	7.5		6.6	1.1	5.6	
t _{EN}	$\overline{\text{OE}}$	A or B	1.0	7.2		6.4	1.0	5.4	
t _{DIS}	$\overline{\text{OE}}$	A or B	1.7	5.9		5.0	1.3	4.6	

Notes:

1. See test circuit and wave forms.
2. Minimum limits are guaranteed but not tested on Propagation Delays.

Operating Characteristics, T_A = 25°C

Parameter		Test Conditions	V _{CC} = 2.5V ±0.2V	V _{CC} = 3.3V ±0.3V	Units
			Typical		
C _{PD} Power Dissipation Capacitance	Outputs Enabled	C _L = 50pF, f = 10 MHz	87	120	pF
	Outputs Disabled		80.5	118	

Power Supply Characteristics

Parameters	Description	Test Conditions ⁽¹⁾	Min.	Typ ⁽²⁾	Max.	Units
I _{CC}	Quiescent Power Supply Current	V _{CC} = Max., I _{OUT} = 0V, V _{IN} = GND or V _{CC}			40	μA
ΔI _{CC}	Supply Current per Input @ TTL HIGH	V _{CC} = 3.0V to 3.6V, One input at V _{CC} - 0.6V Other inputs at V _{CC} or GND			750	μA

Note:

1. For conditions shown as Max. or Min., use appropriate value specified under Electrical Characteristics for the applicable device.