

TTL  
MSI

# TYPES SN54145, SN54LS145, SN74145, SN74LS145 BCD-TO-DECIMAL DECODERS/DRIVERS

BULLETIN NO. DL-S 7611815, MARCH 1974—REVISED OCTOBER 1976

FOR USE AS LAMP, RELAY, OR MOS DRIVERS

- Full Decoding of Input Logic
- SN54145, SN74145, and SN74LS145 Have 80-mA Sink-Current Capability
- All Outputs Are Off for Invalid BCD Input Conditions
- Low Power Dissipation of 'LS145 . . . 35 mW Typical

SN54145, SN54LS145 . . . J OR W PACKAGE  
SN74145, SN74LS145 . . . J OR N PACKAGE  
(TOP VIEW)

logic

FUNCTION TABLE

NO.	INPUTS				OUTPUTS									
	D	C	B	A	0	1	2	3	4	5	6	7	8	9
0	L	L	L	L	L	H	H	H	H	H	H	H	H	H
1	L	L	L	H	H	L	H	H	H	H	H	H	H	H
2	L	L	H	L	H	H	L	H	H	H	H	H	H	H
3	L	L	H	H	H	H	L	H	H	H	H	H	H	H
4	L	H	L	L	H	H	H	L	H	H	H	H	H	H
5	L	H	L	H	H	H	H	H	L	H	H	H	H	H
6	L	H	H	L	H	H	H	H	H	L	H	H	H	H
7	L	H	H	H	H	H	H	H	H	H	L	H	H	H
8	H	L	L	L	H	H	H	H	H	H	H	H	L	H
9	H	L	L	H	H	H	H	H	H	H	H	H	H	L
INVALID	H	L	H	L	H	H	H	H	H	H	H	H	H	H
	H	L	H	H	H	H	H	H	H	H	H	H	H	H
	H	H	L	L	H	H	H	H	H	H	H	H	H	H
	H	H	L	H	H	H	H	H	H	H	H	H	H	H
	H	H	H	L	H	H	H	H	H	H	H	H	H	H

H = high level (off), L = low level (on)

### description

These monolithic BCD-to-decimal decoder/drivers consist of eight inverters and ten four-input NAND gates. The inverters are connected in pairs to make BCD input data available for decoding by the NAND gates. Full decoding of valid BCD input logic ensures that all outputs remain off for all invalid binary input conditions. These decoders feature high-performance, n-p-n output transistors designed for use as indicator/relay drivers or as open-collector logic-circuit drivers. Each of the high-breakdown output transistors (15 volts) of the SN54145, SN74145, or SN74LS145 will sink up to 80 milliamperes of current. Each input is one Series 54/74 or Series 54LS/74LS standard load, respectively. Inputs and outputs are entirely compatible for use with TTL or DTL logic circuits, and the outputs are compatible for interfacing with most MOS integrated circuits. Power dissipation is typically 215 milliwatts for the '145 and 35 milliwatts for the 'LS145.

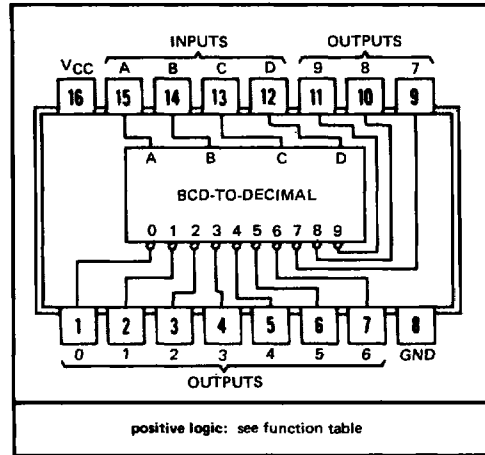

positive logic: see function table

### functional block diagram

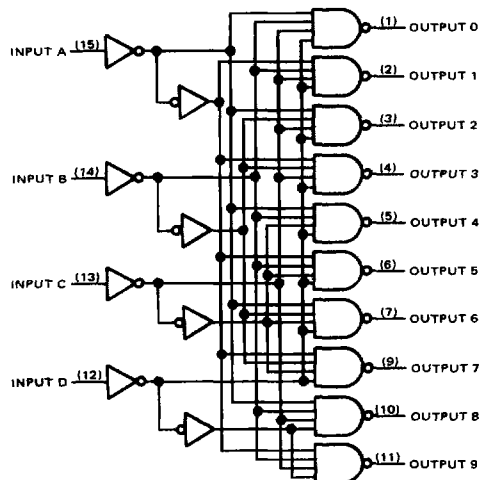

# TYPES SN54145, SN74145 BCD-TO-DECIMAL DECODERS/DRIVERS

absolute maximum ratings over operating free-air temperature range (unless otherwise noted)

Supply voltage, $V_{CC}$ (see Note 1)	7 V
Input voltage	5.5 V
Maximum current into any output (off-state)	1 mA
Operating free-air temperature range: SN54145	-55°C to 125°C
SN74145	0°C to 70°C
Storage temperature range	-65°C to 150°C

NOTE 1: Voltage values are with respect to network ground terminal.

recommended operating conditions

	SN54145			SN74145			UNIT
	MIN	NOM	MAX	MIN	NOM	MAX	
Supply voltage, $V_{CC}$	4.5	5	5.5	4.75	5	5.25	V
Off-state output voltage, $V_{O(off)}$	15			15			V
Operating free-air temperature, $T_A$	-55	125		0	70		°C

electrical characteristics over recommended operating free-air temperature range (unless otherwise noted)

PARAMETER	TEST CONDITIONS†	MIN	TYP‡	MAX	UNIT
$V_{IH}$ High-level input voltage		2			V
$V_{IL}$ Low-level input voltage		0.8			V
$V_{IK}$ Input clamp voltage	$V_{CC} = \text{MIN}$ , $I_I = -12 \text{ mA}$	-1.5			V
$I_{O(off)}$ Off-state output current	$V_{CC} = \text{MIN}$ , $V_{IH} = 2 \text{ V}$ , $V_{IL} = 0.8 \text{ V}$ , $V_{O(off)} = 15 \text{ V}$	250			$\mu\text{A}$
$V_{O(on)}$ On-state output voltage	$V_{CC} = \text{MIN}$ , $V_{IH} = 2 \text{ V}$ , $V_{IL} = 0.8 \text{ V}$	$I_{O(on)} = 80 \text{ mA}$	0.5	0.9	V
		$I_{O(on)} = 20 \text{ mA}$	0.4		
$I_I$ Input current at maximum input voltage	$V_{CC} = \text{MAX}$ , $V_I = 5.5 \text{ V}$	1			mA
$I_{IH}$ High-level input current	$V_{CC} = \text{MAX}$ , $V_I = 2.4 \text{ V}$	40			$\mu\text{A}$
$I_{IL}$ Low-level input current	$V_{CC} = \text{MAX}$ , $V_I = 0.4 \text{ V}$	-1.6			mA
$I_{CC}$ Supply current	$V_{CC} = \text{MAX}$ , See Note 2	SN54145	43	62	mA
		SN74145	43	70	

† For conditions shown as MIN or MAX, use the appropriate value specified under recommended operating conditions.

‡ All typical values are at  $V_{CC} = 5 \text{ V}$ ,  $T_A = 25^\circ\text{C}$ .

NOTE 2:  $I_{CC}$  is measured with all inputs grounded and outputs open.

switching characteristics,  $V_{CC} = 5 \text{ V}$ ,  $T_A = 25^\circ\text{C}$

PARAMETER	TEST CONDITIONS	MIN	MAX	UNIT
$t_{PLH}$ Propagation delay time, low-to-high-level output	$C_L = 15 \text{ pF}$ , $R_L = 100 \Omega$ , See Note 3	50		ns
$t_{PHL}$ Propagation delay time, high-to-low-level output		50		ns

NOTE 3: Load circuit and waveforms are shown on page 3-10.

schematics of inputs and outputs

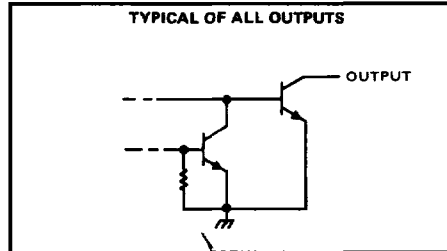
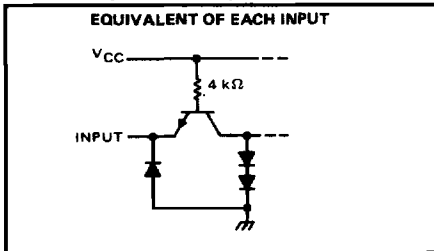

# TYPES SN54LS145, SN74LS145

## BCD-TO-DECIMAL DECODERS/DRIVERS

REVISED OCTOBER 1976

absolute maximum ratings over operating free-air temperature range (unless otherwise noted)

Supply voltage, $V_{CC}$ (see Note 1)	7 V
Input voltage	7 V
Operating free-air temperature range: SN54LS145	-55°C to 125°C
SN74LS145	0°C to 70°C
Storage temperature range	-65°C to 150°C

NOTE 1: Voltage values are with respect to network ground terminal.

recommended operating conditions

	SN54LS145			SN74LS145			UNIT
	MIN	NOM	MAX	MIN	NOM	MAX	
Supply voltage, $V_{CC}$	4.5	5	5.5	4.75	5	5.25	V
Off-state output voltage, $V_{O(off)}$	15			15			V
Operating free-air temperature, $T_A$	-55			0			70 °C

electrical characteristics over recommended operating free-air temperature range (unless otherwise noted)

PARAMETER	TEST CONDITIONS†	SN54LS145			SN74LS145			UNIT
		MIN	TYP‡	MAX	MIN	TYP‡	MAX	
$V_{IH}$ High-level input voltage		2			2			V
$V_{IL}$ Low-level input voltage		0.7			0.8			V
$V_{IK}$ Input clamp voltage	$V_{CC} = \text{MIN}, I_I = -18 \text{ mA}$	-1.5			-1.5			V
$I_{O(off)}$ Off-state output current	$V_{CC} = \text{MIN}, V_{IH} = 2 \text{ V}, V_{IL} = V_{IL \text{ max}}, V_{OH} = 15 \text{ V}$	250			250			$\mu\text{A}$
$V_{O(on)}$ On-state output voltage	$V_{CC} = \text{MIN}, V_{IH} = 2 \text{ V}, V_{IL} = V_{IL \text{ max}}$	$I_{OL} = 12 \text{ mA}$	0.25	0.4	0.25	0.4	V	
		$I_{OL} = 24 \text{ mA}$				0.35		0.5
		$I_{OL} = 80 \text{ mA}$				2.3		3
$I_I$ Input current at maximum input voltage	$V_{CC} = \text{MAX}, V_I = 7 \text{ V}$	0.1			0.1			mA
$I_{IH}$ High-level input current	$V_{CC} = \text{MAX}, V_I = 2.7 \text{ V}$	20			20			$\mu\text{A}$
$I_{IL}$ Low-level input current	$V_{CC} = \text{MAX}, V_I = 0.4 \text{ V}$	-0.4			-0.4			mA
$I_{CC}$ Supply current	$V_{CC} = \text{MAX},$ See Note 2	7	13	7	13	mA		

†For conditions shown as MIN or MAX, use the appropriate value specified under recommended operating conditions.

‡All typical values are at  $V_{CC} = 5 \text{ V}, T_A = 25^\circ\text{C}$ .

NOTE 2:  $I_{CC}$  is measured with all inputs grounded and outputs open.

switching characteristics,  $V_{CC} = 5 \text{ V}, T_A = 25^\circ\text{C}$

PARAMETER	TEST CONDITIONS	MIN	MAX	UNIT
$t_{PLH}$ Propagation delay time, low-to-high-level output	$C_L = 45 \text{ pF}, R_L = 665 \Omega,$ See Note 4			50 ns
$t_{PHL}$ Propagation delay time, high-to-low-level output				50 ns

NOTE 4: Load circuit and waveforms are shown on page 3-11.

schematic of inputs and outputs

