

Quad Analog Switch/Quad Multiplexer

The MC14016B quad bilateral switch is constructed with MOS P-channel and N-channel enhancement mode devices in a single monolithic structure. Each MC14016B consists of four independent switches capable of controlling either digital or analog signals. The quad bilateral switch is used in signal gating, chopper, modulator, demodulator and CMOS logic implementation.

- Diode Protection on All Inputs
- Supply Voltage Range = 3.0 Vdc to 18 Vdc
- Linearized Transfer Characteristics
- Low Noise — $12 \text{ nV}/\sqrt{\text{Cycle}}$, $f \geq 1.0 \text{ kHz}$ typical
- Pin-for-Pin Replacements for CD4016B, CD4066B (Note improved transfer characteristic design causes more parasitic coupling capacitance than CD4016)
- For Lower R_{ON} , Use The HC4016 High-Speed CMOS Device or The MC14066B
- This Device Has Inputs and Outputs Which Do Not Have ESD Protection. Antistatic Precautions Must Be Taken.

MAXIMUM RATINGS* (Voltages Referenced to V_{SS})

Symbol	Parameter	Value	Unit
V_{DD}	DC Supply Voltage	- 0.5 to + 18.0	V
V_{in}, V_{out}	Input or Output Voltage (DC or Transient)	- 0.5 to $V_{DD} + 0.5$	V
I_{in}	Input Current (DC or Transient), per Control Pin	± 10	mA
I_{sw}	Switch Through Current	± 25	mA
P_D	Power Dissipation, per Package†	500	mW
T_{stg}	Storage Temperature	- 65 to + 150	°C
T_L	Lead Temperature (8-Second Soldering)	260	°C

* Maximum Ratings are those values beyond which damage to the device may occur.

† Temperature Derating:

Plastic "P and D/DW" Packages: - 7.0 mW/°C From 65°C To 125°C

Ceramic "L" Packages: - 12 mW/°C From 100°C To 125°C

This device contains protection circuitry to guard against damage due to high static voltages or electric fields. However, precautions must be taken to avoid applications of any voltage higher than maximum rated voltages to this high-impedance circuit. For proper operation, V_{in} and V_{out} should be constrained to the range $V_{SS} \leq (V_{in} \text{ or } V_{out}) \leq V_{DD}$.

Unused inputs must always be tied to an appropriate logic voltage level (e.g., either V_{SS} or V_{DD}). Unused outputs must be left open.

LOGIC DIAGRAM (1/4 OF DEVICE SHOWN)

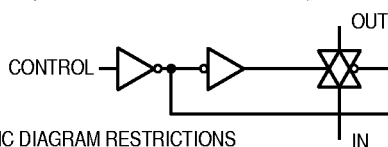

LOGIC DIAGRAM RESTRICTIONS

$$V_{SS} \leq V_{in} \leq V_{DD}$$

$$V_{SS} \leq V_{out} \leq V_{DD}$$

MC14016B

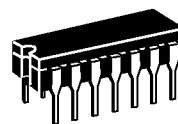

L SUFFIX
CERAMIC
CASE 632

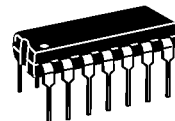

P SUFFIX
PLASTIC
CASE 646



D SUFFIX
SOIC
CASE 751A

ORDERING INFORMATION

MC14XXXBCP Plastic
MC14XXXBCL Ceramic
MC14XXXBD SOIC

$T_A = -55^\circ \text{ to } 125^\circ \text{C}$ for all packages.

BLOCK DIAGRAM

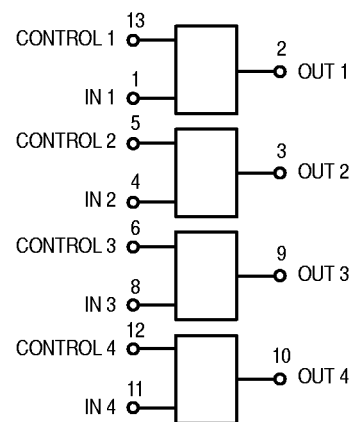

$V_{DD} = \text{PIN } 14$
 $V_{SS} = \text{PIN } 7$

Control	Switch
0 = V_{SS}	Off
1 = V_{DD}	On



ELECTRICAL CHARACTERISTICS (Voltages Referenced to V_{SS})

Characteristic	Figure	Symbol	V_{DD} Vdc	- 55°C		25°C			125°C		Unit
				Min	Max	Min	Typ #	Max	Min	Max	
Input Voltage Control Input	1	V_{IL}	5.0	—	—	—	1.5	0.9	—	—	Vdc
			10	—	—	—	1.5	0.9	—	—	
			15	—	—	—	1.5	0.9	—	—	
		V_{IH}	5.0	—	—	3.0	2.0	—	—	—	Vdc
			10	—	—	8.0	6.0	—	—	—	
			15	—	—	13	11	—	—	—	
Input Current Control	—	I_{in}	15	—	± 0.1	—	± 0.00001	± 0.1	—	± 1.0	μ Adc
Input Capacitance Control Switch Input Switch Output Feed Through	—	C_{in}	—	—	—	—	5.0	—	—	—	pF
			—	—	—	—	5.0	—	—	—	
			—	—	—	—	5.0	—	—	—	
			—	—	—	—	0.2	—	—	—	
Quiescent Current (Per Package)	2,3	I_{DD}	5.0	—	0.25	—	0.0005	0.25	—	7.5	μ Adc
			10	—	0.5	—	0.0010	0.5	—	15	
			15	—	1.0	—	0.0015	1.0	—	30	
"ON" Resistance ($V_C = V_{DD}$, $R_L = 10\text{ k}\Omega$) ($V_{in} = + 5.0\text{ Vdc}$) ($V_{in} = - 5.0\text{ Vdc}$) $V_{SS} = - 5.0\text{ Vdc}$ ($V_{in} = \pm 0.25\text{ Vdc}$) ($V_{in} = + 7.5\text{ Vdc}$) ($V_{in} = - 7.5\text{ Vdc}$) $V_{SS} = - 7.5\text{ Vdc}$ ($V_{in} = \pm 0.25\text{ Vdc}$) ($V_{in} = + 10\text{ Vdc}$) ($V_{in} = + 0.25\text{ Vdc}$) $V_{SS} = 0\text{ Vdc}$ ($V_{in} = + 5.6\text{ Vdc}$) ($V_{in} = + 15\text{ Vdc}$) ($V_{in} = + 0.25\text{ Vdc}$) $V_{SS} = 0\text{ Vdc}$ ($V_{in} = + 9.3\text{ Vdc}$)	4,5,6	R_{ON}	5.0	—	600	—	300	660	—	840	Ohms
			5.0	—	600	—	300	660	—	840	
			5.0	—	600	—	280	660	—	840	
			7.5	—	360	—	240	400	—	520	
			7.5	—	360	—	240	400	—	520	
			7.5	—	360	—	180	400	—	520	
			10	—	600	—	260	660	—	840	
			10	—	600	—	310	660	—	840	
			10	—	600	—	310	660	—	840	
			15	—	360	—	260	400	—	520	
			15	—	360	—	260	400	—	520	
			15	—	360	—	300	400	—	520	
Δ "ON" Resistance Between any 2 circuits in a common package ($V_C = V_{DD}$) ($V_{in} = \pm 5.0\text{ Vdc}$, $V_{SS} = - 5.0\text{ Vdc}$) ($V_{in} = \pm 7.5\text{ Vdc}$, $V_{SS} = - 7.5\text{ Vdc}$)	—	ΔR_{ON}	5.0	—	—	—	15	—	—	—	Ohms
			7.5	—	—	—	10	—	—	—	
Input/Output Leakage Current ($V_C = V_{SS}$) ($V_{in} = + 7.5$, $V_{out} = - 7.5\text{ Vdc}$) ($V_{in} = - 7.5$, $V_{out} = + 7.5\text{ Vdc}$)	—	—	7.5	—	± 0.1	—	± 0.0015	± 0.1	—	± 1.0	μ Adc
			7.5	—	± 0.1	—	± 0.0015	± 0.1	—	± 1.0	

NOTE: All unused inputs must be returned to V_{DD} or V_{SS} as appropriate for the circuit application.

#Data labelled "Typ" is not to be used for design purposes but is intended as an indication of the IC's potential performance.

** For voltage drops across the switch (ΔV_{switch}) > 600 mV (> 300 mV at high temperature), excessive V_{DD} current may be drawn; i.e., the current out of the switch may contain both V_{DD} and switch input components. The reliability of the device will be unaffected unless the Maximum Ratings are exceeded. (See first page of this data sheet.) Reference Figure 14.

ELECTRICAL CHARACTERISTICS* ($C_L = 50 \text{ pF}$, $T_A = 25^\circ\text{C}$)

Characteristic	Figure	Symbol	V _{DD} Vdc	Min	Typ #	Max	Unit			
Propagation Delay Time ($V_{SS} = 0 \text{ Vdc}$) V_{in} to V_{out} ($V_C = V_{DD}$, $R_L = 10 \text{ k}\Omega$)	7	t_{PLH}	5.0	—	15	45	ns			
		t_{PHL}	10	—	7.0	15				
			15	—	6.0	12				
Control to Output ($V_{in} \leq 10 \text{ Vdc}$, $R_L = 10 \text{ k}\Omega$)	8	t_{PHZ}	5.0	—	34	90	ns			
		t_{PLZ}	10	—	20	45				
		t_{PZH}	15	—	15	35				
		t_{PZL}	15	—	15	35				
Crosstalk, Control to Output ($V_{SS} = 0 \text{ Vdc}$) ($V_C = V_{DD}$, $R_{in} = 10 \text{ k}\Omega$, $R_{out} = 10 \text{ k}\Omega$, $f = 1.0 \text{ kHz}$)	9	—	5.0	—	30	—	mV			
			10	—	50	—				
			15	—	100	—				
Crosstalk between any two switches ($V_{SS} = 0 \text{ Vdc}$) ($R_L = 1.0 \text{ k}\Omega$, $f = 1.0 \text{ MHz}$, crosstalk = $20 \log_{10} \frac{V_{out1}}{V_{out2}}$)	—	—	5.0	—	-80	—	dB			
Noise Voltage ($V_{SS} = 0 \text{ Vdc}$) ($V_C = V_{DD}$, $f = 100 \text{ Hz}$) ($V_C = V_{DD}$, $f = 100 \text{ kHz}$)	10,11	—	5.0	—	24	—	nV/ $\sqrt{\text{Cycle}}$			
			10	—	25	—				
			15	—	30	—				
			5.0	—	12	—				
			10	—	12	—				
15	—	15	—							
Second Harmonic Distortion ($V_{SS} = -5.0 \text{ Vdc}$) ($V_{in} = 1.77 \text{ Vdc}$, RMS Centered @ 0.0 Vdc , $R_L = 10 \text{ k}\Omega$, $f = 1.0 \text{ kHz}$)	—	—	5.0	—	0.16	—	%			
Insertion Loss ($V_C = V_{DD}$, $V_{in} = 1.77 \text{ Vdc}$, $V_{SS} = -5.0 \text{ Vdc}$, RMS centered = 0.0 Vdc , $f = 1.0 \text{ MHz}$) $I_{loss} = 20 \log_{10} \frac{V_{out}}{V_{in}}$ ($R_L = 1.0 \text{ k}\Omega$) ($R_L = 10 \text{ k}\Omega$) ($R_L = 100 \text{ k}\Omega$) ($R_L = 1.0 \text{ M}\Omega$)	12	—	5.0	—	2.3	—	dB			
								—	0.2	—
								—	0.1	—
								—	0.05	—
								—	0.05	—
Bandwidth (-3.0 dB) ($V_C = V_{DD}$, $V_{in} = 1.77 \text{ Vdc}$, $V_{SS} = -5.0 \text{ Vdc}$, RMS centered @ 0.0 Vdc) ($R_L = 1.0 \text{ k}\Omega$) ($R_L = 10 \text{ k}\Omega$) ($R_L = 100 \text{ k}\Omega$) ($R_L = 1.0 \text{ M}\Omega$)	12,13	BW	5.0	—	54	—	MHz			
								—	40	—
								—	38	—
								—	37	—
								—	37	—
OFF Channel Feedthrough Attenuation ($V_{SS} = -5.0 \text{ Vdc}$) ($V_C = V_{SS}$, $20 \log_{10} \frac{V_{out}}{V_{in}} = -50 \text{ dB}$) ($R_L = 1.0 \text{ k}\Omega$) ($R_L = 10 \text{ k}\Omega$) ($R_L = 100 \text{ k}\Omega$) ($R_L = 1.0 \text{ M}\Omega$)	—	—	5.0	—	1250	—	kHz			
								—	140	—
								—	18	—
								—	2.0	—
								—	2.0	—

#Data labelled "Typ" is not to be used for design purposes but is intended as an indication of the IC's potential performance.

PIN ASSIGNMENT

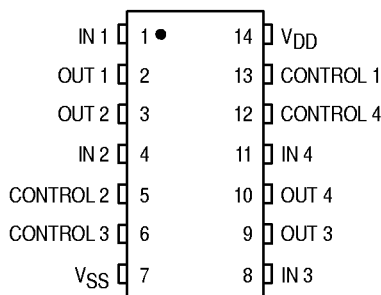

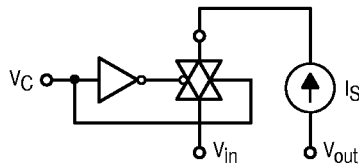

V_{IL} : V_C is raised from V_{SS} until $V_C = V_{IL}$.
 at $V_C = V_{IL}$: $I_S = \pm 10 \mu A$ with $V_{in} = V_{SS}$, $V_{out} = V_{DD}$ or $V_{in} = V_{DD}$, $V_{out} = V_{SS}$.
 V_{IH} : When $V_C = V_{IH}$ to V_{DD} , the switch is ON and the R_{ON} specifications are met.

Figure 1. Input Voltage Test Circuit

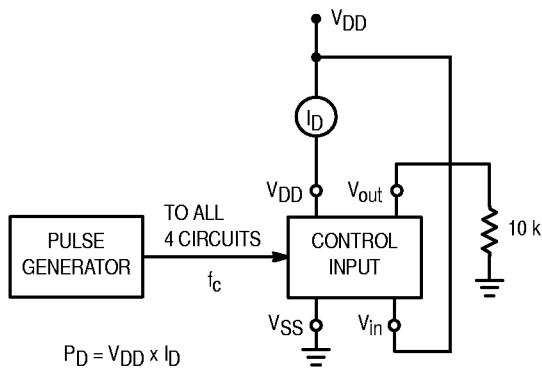

Figure 2. Quiescent Power Dissipation Test Circuit

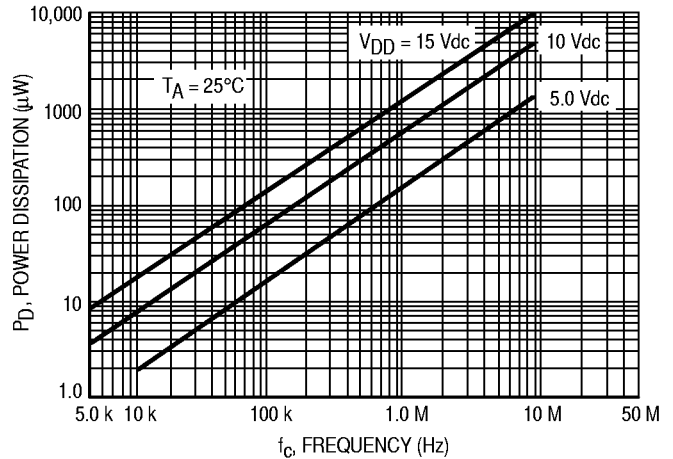

Figure 3. Typical Power Dissipation per Circuit (1/4 of device shown)

TYPICAL R_{ON} versus INPUT VOLTAGE

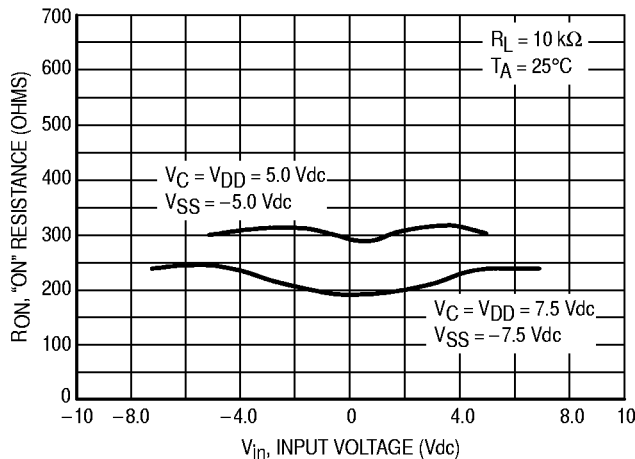

Figure 4. $V_{SS} = -5.0 V$ and $-7.5 V$

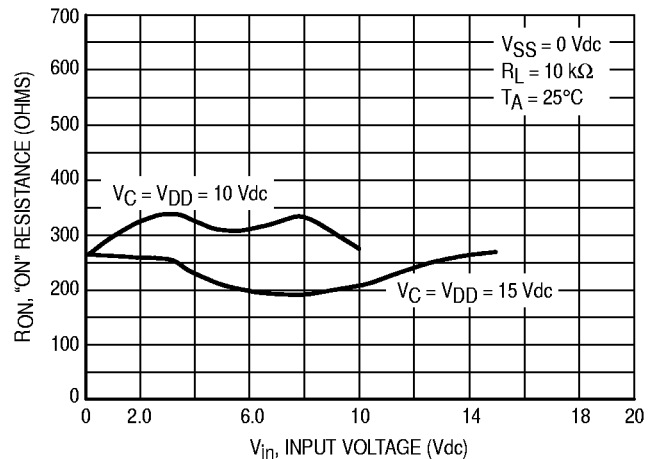

Figure 5. $V_{SS} = 0 V$

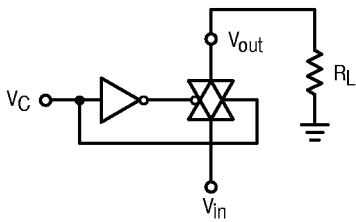

Figure 6. R_{ON} Characteristics Test Circuit

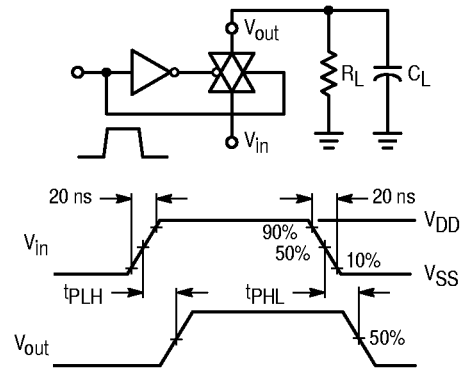

Figure 7. Propagation Delay Test Circuit and Waveforms

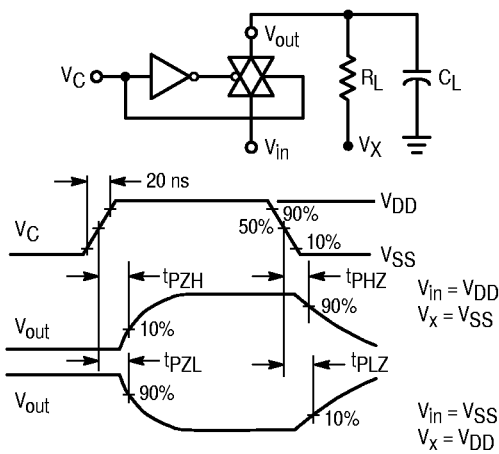

Figure 8. Turn-On Delay Time Test Circuit and Waveforms

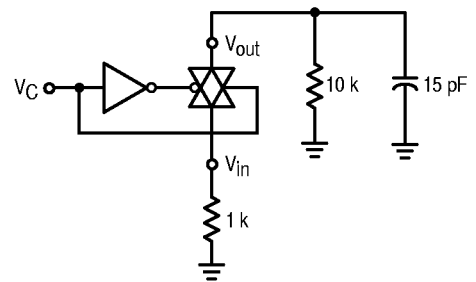

Figure 9. Crosstalk Test Circuit

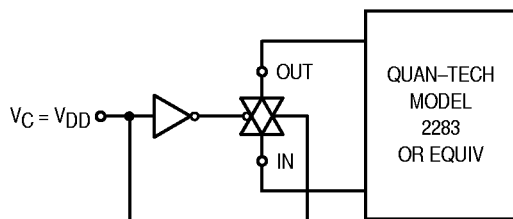

Figure 10. Noise Voltage Test Circuit

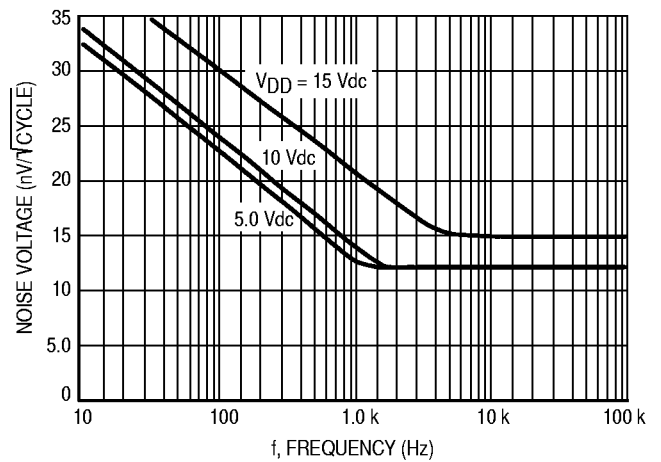

Figure 11. Typical Noise Characteristics

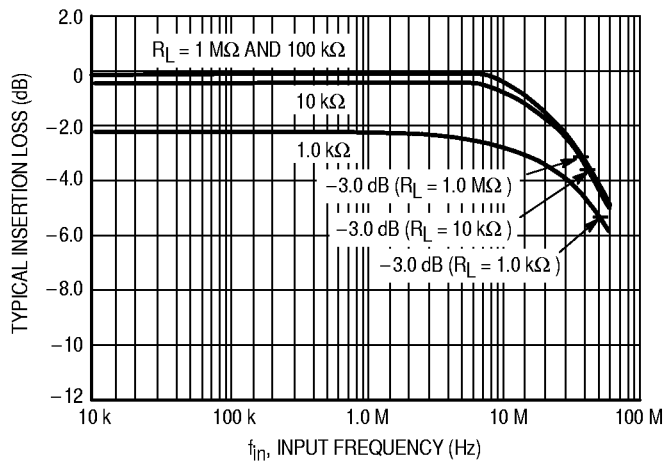

Figure 12. Typical Insertion Loss/Bandwidth Characteristics

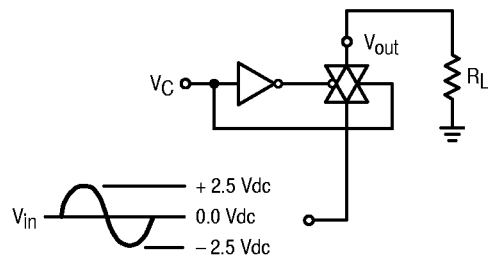

Figure 13. Frequency Response Test Circuit

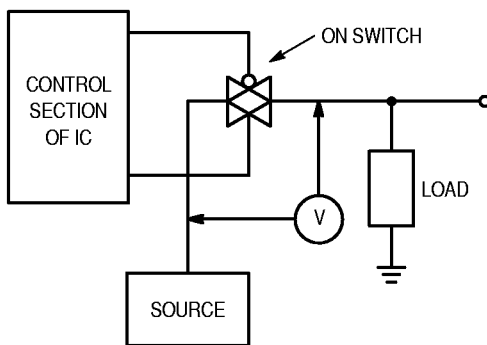

Figure 14. ΔV Across Switch

APPLICATIONS INFORMATION

Figure A illustrates use of the Analog Switch. The 0-to-5 V Digital Control signal is used to directly control a 5 V_{p-p} analog signal.

The digital control logic levels are determined by V_{DD} and V_{SS}. The V_{DD} voltage is the logic high voltage; the V_{SS} voltage is logic low. For the example, V_{DD} = +5 V logic high at the control inputs; V_{SS} = GND = 0 V logic low.

The maximum analog signal level is determined by V_{DD} and V_{SS}. The analog voltage must not swing higher than V_{DD} or lower than V_{SS}.

The example shows a 5 V_{p-p} signal which allows no margin at either peak. If voltage transients above V_{DD} and/or below V_{SS} are anticipated on the analog channels, external diodes (D_x) are recommended as shown in Figure B. These diodes should be small signal types able to absorb the maximum anticipated current surges during clipping.

The *absolute* maximum potential difference between V_{DD} and V_{SS} is 18.0 V. Most parameters are specified up to 15 V which is the *recommended* maximum difference between V_{DD} and V_{SS}.

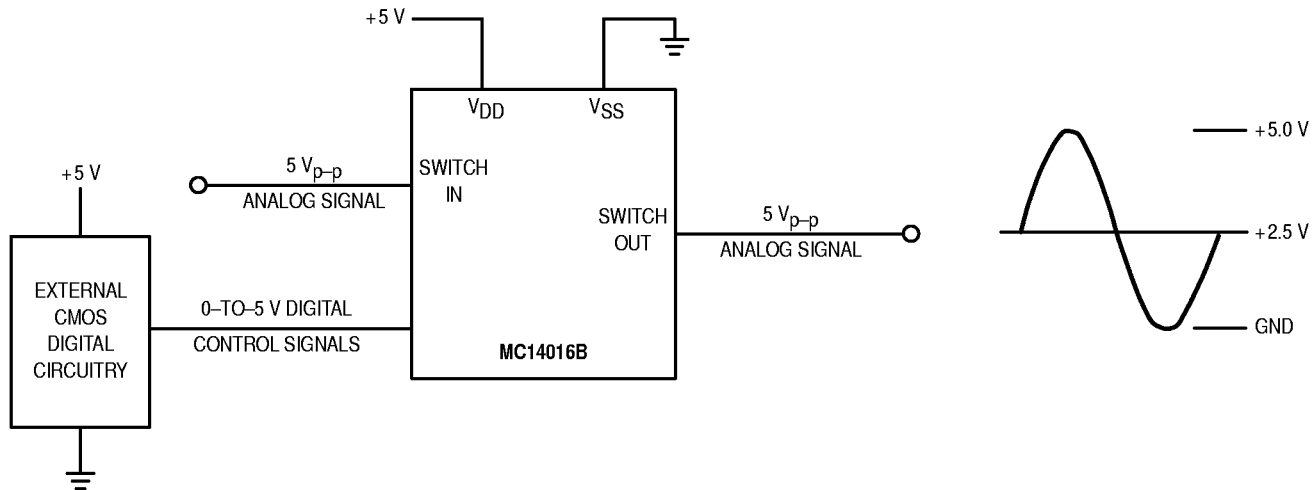

Figure A. Application Example



Figure B. External Germanium or Schottky Clipping Diodes

OUTLINE DIMENSIONS

L SUFFIX CERAMIC DIP PACKAGE CASE 632-08 ISSUE Y

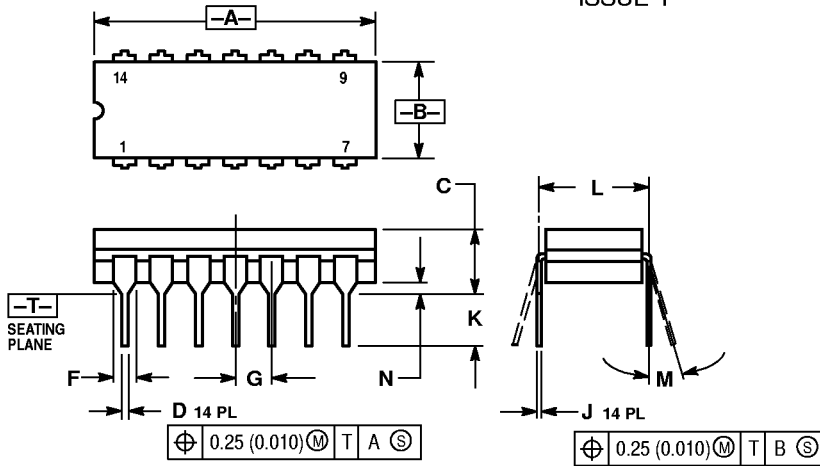

- NOTES:
1. DIMENSIONING AND TOLERANCING PER ANSI Y14.5M, 1982.
 2. CONTROLLING DIMENSION: INCH.
 3. DIMENSION L TO CENTER OF LEAD WHEN FORMED PARALLEL.
 4. DIMENSION F MAY NARROW TO 0.76 (0.030) WHERE THE LEAD ENTERS THE CERAMIC BODY.

P SUFFIX PLASTIC DIP PACKAGE CASE 646-06 ISSUE L

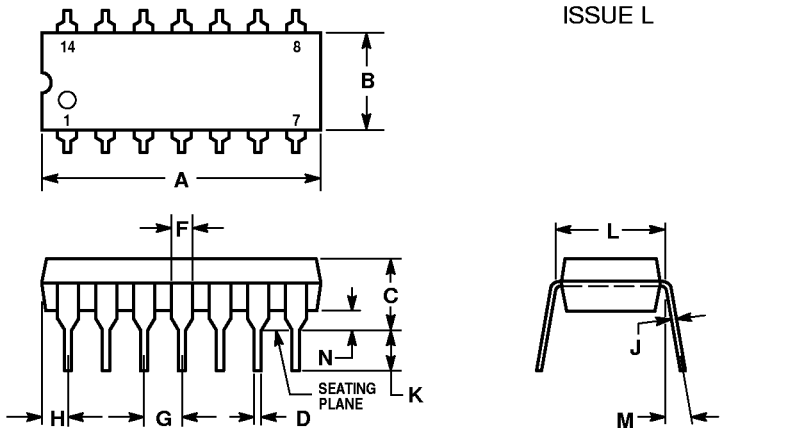

- NOTES:
1. LEADS WITHIN 0.13 (0.005) RADIUS OF TRUE POSITION AT SEATING PLANE AT MAXIMUM MATERIAL CONDITION.
 2. DIMENSION L TO CENTER OF LEADS WHEN FORMED PARALLEL.
 3. DIMENSION B DOES NOT INCLUDE MOLD FLASH.
 4. ROUNDED CORNERS OPTIONAL.

OUTLINE DIMENSIONS

D SUFFIX PLASTIC SOIC PACKAGE CASE 751A-03 ISSUE F

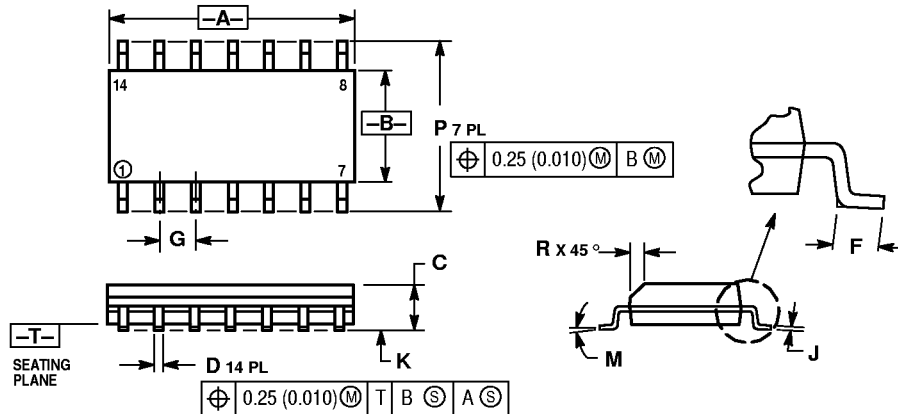

NOTES:

1. DIMENSIONING AND TOLERANCING PER ANSI Y14.5M, 1982.
2. CONTROLLING DIMENSION: MILLIMETER.
3. DIMENSIONS A AND B DO NOT INCLUDE MOLD PROTRUSION.
4. MAXIMUM MOLD PROTRUSION 0.15 (0.006) PER SIDE.
5. DIMENSION D DOES NOT INCLUDE DAMBAR PROTRUSION. ALLOWABLE DAMBAR PROTRUSION SHALL BE 0.127 (0.005) TOTAL IN EXCESS OF THE D DIMENSION AT MAXIMUM MATERIAL CONDITION.

DIM	MILLIMETERS		INCHES	
	MIN	MAX	MIN	MAX
A	8.55	8.75	0.337	0.344
B	3.80	4.00	0.150	0.157
C	1.35	1.75	0.054	0.068
D	0.35	0.49	0.014	0.019
F	0.40	1.25	0.016	0.049
G	1.27 BSC		0.050 BSC	
J	0.19	0.25	0.008	0.009
K	0.10	0.25	0.004	0.009
M	0°	7°	0°	7°
P	5.80	6.20	0.228	0.244
R	0.25	0.50	0.010	0.019

Motorola reserves the right to make changes without further notice to any products herein. Motorola makes no warranty, representation or guarantee regarding the suitability of its products for any particular purpose, nor does Motorola assume any liability arising out of the application or use of any product or circuit, and specifically disclaims any and all liability, including without limitation consequential or incidental damages. "Typical" parameters which may be provided in Motorola data sheets and/or specifications can and do vary in different applications and actual performance may vary over time. All operating parameters, including "Typicals" must be validated for each customer application by customer's technical experts. Motorola does not convey any license under its patent rights nor the rights of others. Motorola products are not designed, intended, or authorized for use as components in systems intended for surgical implant into the body, or other applications intended to support or sustain life, or for any other application in which the failure of the Motorola product could create a situation where personal injury or death may occur. Should Buyer purchase or use Motorola products for any such unintended or unauthorized application, Buyer shall indemnify and hold Motorola and its officers, employees, subsidiaries, affiliates, and distributors harmless against all claims, costs, damages, and expenses, and reasonable attorney fees arising out of, directly or indirectly, any claim of personal injury or death associated with such unintended or unauthorized use, even if such claim alleges that Motorola was negligent regarding the design or manufacture of the part. Motorola and  are registered trademarks of Motorola, Inc. Motorola, Inc. is an Equal Opportunity/Affirmative Action Employer.

How to reach us:

USA/EUROPE/Locations Not Listed: Motorola Literature Distribution;
P.O. Box 20912; Phoenix, Arizona 85036. 1-800-441-2447 or 602-303-5454

MFAX: RMFAX0@email.sps.mot.com – TOUCHTONE 602-244-6609
INTERNET: <http://Design-NET.com>

JAPAN: Nippon Motorola Ltd.; Tatsumi-SPD-JLDC, 6F Seibu-Butsuryu-Center,
3-14-2 Tatsumi Koto-Ku, Tokyo 135, Japan. 03-81-3521-8315

ASIA/PACIFIC: Motorola Semiconductors H.K. Ltd.; 8B Tai Ping Industrial Park,
51 Ting Kok Road, Tai Po, N.T., Hong Kong. 852-26629298



MC14016B/D

