

# SN74F112

## DUAL NEGATIVE-EDGE-TRIGGERED J-K FLIP-FLOP WITH CLEAR AND PRESET

SDFS048A - D2932, MARCH 1987 - REVISED OCTOBER 1993

- Package Options Include Plastic Small-Outline Packages and Standard Plastic 300-mil DIPs

### description

The SN74F112 contains two independent J-K negative-edge-triggered flip-flops. A low level at the preset ( $\overline{PRE}$ ) or clear ( $\overline{CLR}$ ) inputs sets or resets the outputs regardless of the levels of the other inputs. When  $\overline{PRE}$  and  $\overline{CLR}$  are inactive (high), data at the J and K inputs meeting the setup time requirements is transferred to the outputs on the negative-going edge of the clock pulse. Clock triggering occurs at a voltage level and is not directly related to the rise time of the clock pulse. Following the hold-time interval, data at the J and K inputs may be changed without affecting the levels at the outputs. The SN74F112 can perform as a toggle flip-flop by tying J and K high.

The SN74F112 is characterized for operation from 0°C to 70°C.

### D OR N PACKAGE (TOP VIEW)

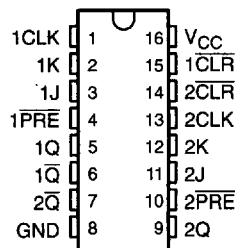

FUNCTION TABLE

INPUTS					OUTPUTS	
$\overline{PRE}$	$\overline{CLR}$	CLK	J	K	Q	$\overline{Q}$
L	H	X	X	X	H	L
H	L	X	X	X	L	H
L	L	X	X	X	H†	H†
H	H	↓	L	L	Q <sub>0</sub>	$\overline{Q}_0$
H	H	↓	H	L	H	L
H	H	↓	L	H	L	H
H	H	↓	H	H	Toggle	
H	H	H	X	X	Q <sub>0</sub>	$\overline{Q}_0$

† The output levels in this configuration are not guaranteed to meet the minimum levels for  $V_{OH}$ . Furthermore, this configuration is nonstable; that is, it will not persist when either PRE or CLR returns to its inactive (high) level.

# SN74F112

## DUAL NEGATIVE-EDGE-TRIGGERED J-K FLIP-FLOP WITH CLEAR AND PRESET

SDFS048A - D2932, MARCH 1987 - REVISED OCTOBER 1993

### logic symbol†

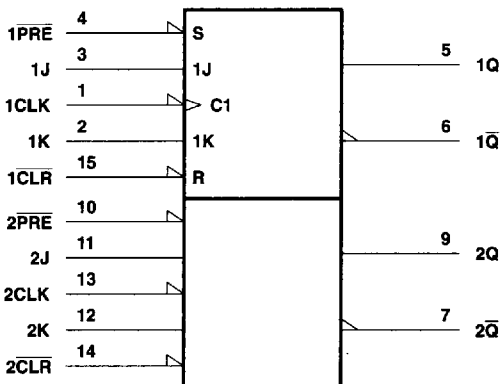

† This symbol is in accordance with ANSI/IEEE Std 91-1984 and IEC Publication 617-12.

### logic diagram, each flip-flop (positive logic)

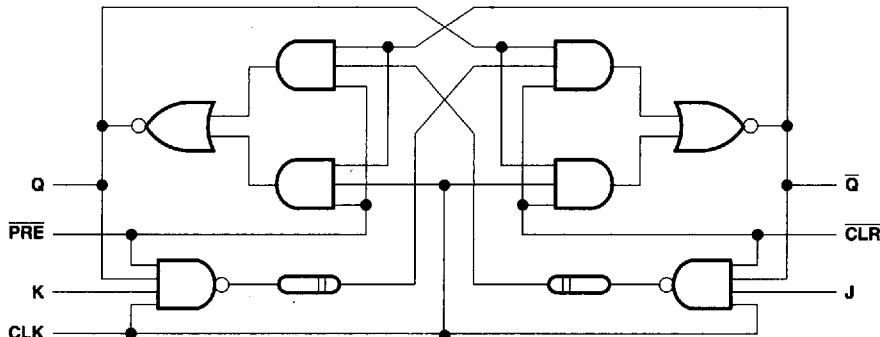

### absolute maximum ratings over operating free-air temperature range (unless otherwise noted)‡

Supply voltage range, $V_{CC}$ .....	-0.5 V to 7 V
Input voltage range, $V_I$ (see Note 1) .....	-1.2 V to 7 V
Input current range .....	-30 mA to 5 mA
Voltage range applied to any output in the high state .....	-0.5 V to $V_{CC}$
Current into any output in the low state .....	40 mA
Operating free-air temperature range .....	0°C to 70°C
Storage temperature range .....	-65°C to 150°C

‡ Stresses beyond those listed under "absolute maximum ratings" may cause permanent damage to the device. These are stress ratings only and functional operation of the device at these or any other conditions beyond those indicated under "recommended operating conditions" is not implied. Exposure to absolute-maximum-rated conditions for extended periods may affect device reliability.

NOTE 1: The input voltage ratings may be exceeded provided the input current ratings are observed.

8961723 0096366 051



POST OFFICE BOX 655303 • DALLAS, TEXAS 75265

# SN74F112

## DUAL NEGATIVE-EDGE-TRIGGERED J-K FLIP-FLOP WITH CLEAR AND PRESET

SDFS048A - D2932, MARCH 1987 - REVISED OCTOBER 1993

### recommended operating conditions

		MIN	NOM	MAX	UNIT
V <sub>CC</sub>	Supply voltage	4.5	5	5.5	V
V <sub>IH</sub>	High-level input voltage	2			V
V <sub>IL</sub>	Low-level input voltage			0.8	V
I <sub>IK</sub>	Input clamp current			-18	mA
I <sub>OH</sub>	High-level output current			-1	mA
I <sub>OL</sub>	Low-level output current			20	mA
T <sub>A</sub>	Operating free-air temperature	0		70	°C

### electrical characteristics over recommended operating free-air temperature range (unless otherwise noted)

PARAMETER		TEST CONDITIONS		MIN	TYP†	MAX	UNIT
V <sub>IK</sub>		V <sub>CC</sub> = 4.5 V,	I <sub>I</sub> = -18 mA			-1.2	V
V <sub>OH</sub>		V <sub>CC</sub> = 4.5 V,	I <sub>OH</sub> = -1 mA	2.5	3.4		V
		V <sub>CC</sub> = 4.75 V,	I <sub>OH</sub> = -1 mA	2.7			
V <sub>OL</sub>		V <sub>CC</sub> = 4.5 V,	I <sub>OL</sub> = 20 mA		0.3	0.5	V
I <sub>I</sub>		V <sub>CC</sub> = 5.5 V,	V <sub>I</sub> = 7 V			0.1	mA
I <sub>IH</sub>		V <sub>CC</sub> = 5.5 V,	V <sub>I</sub> = 2.7 V			20	μA
I <sub>IL</sub>	J or K	V <sub>CC</sub> = 5.5 V,	V <sub>I</sub> = 0.5 V			-0.6	mA
	PRE or CLR					-3	
	CLK					-2.4	
I <sub>OS</sub> ‡		V <sub>CC</sub> = 5.5 V,	V <sub>O</sub> = 0	-60		-150	mA
I <sub>CC</sub>		V <sub>CC</sub> = 5.5 V,	See Note 2		12	19	mA

† All typical values are at V<sub>CC</sub> = 5 V, T<sub>A</sub> = 25°C.

‡ Not more than one output should be shorted at a time, and the duration of the short circuit should not exceed one second.

NOTE 2: I<sub>CC</sub> is measured with all outputs open, the Q and  $\bar{Q}$  outputs alternately high and the clock input grounded at the time of measurement.

### timing requirements over recommended ranges of supply voltage and operating free-air temperature (unless otherwise noted)

		V <sub>CC</sub> = 5 V, T <sub>A</sub> = 25°C		MIN	MAX	UNIT
		MIN	MAX			
f <sub>clock</sub>	Clock frequency	0	110	0	100	MHz
t <sub>w</sub>	Pulse duration	CLK high or low	4.5	5		ns
		CLR or PRE low	4.5	5		
t <sub>su</sub>	Setup time, data before CLK↓	High	4	5		ns
		Low	3	3.5		
t <sub>h</sub>	Hold time, data after CLK↓	High	0	0		ns
		Low	0	0		
t <sub>su</sub>	Setup time, inactive state, data before CLK↓§	CLR or PRE high	4	5		ns

§ Inactive-state setup time is also referred to as recovery time.

**SN74F112**  
**DUAL NEGATIVE-EDGE-TRIGGERED J-K FLIP-FLOP**  
**WITH CLEAR AND PRESET**

SDFS048A - D2932, MARCH 1987 - REVISED OCTOBER 1993

**switching characteristics (see Note 3)**

PARAMETER	FROM (INPUT)	TO (OUTPUT)	V <sub>CC</sub> = 5 V, C <sub>L</sub> = 50 pF, R <sub>L</sub> = 500 Ω, T <sub>A</sub> = 25°C			V <sub>CC</sub> = 4.5 V to 5.5 V, C <sub>L</sub> = 50 pF, R <sub>L</sub> = 500 Ω, T <sub>A</sub> = MIN to MAX†		UNIT
			MIN	TYP	MAX	MIN	MAX	
f <sub>max</sub>			110	130		100		MHz
t <sub>PLH</sub>	CLK	Q or $\bar{Q}$	1.2	4.6	6.5	1.2	7.5	ns
t <sub>PHL</sub>			1.2	4.6	6.5	1.2	7.5	
t <sub>PLH</sub>	$\overline{\text{PRE}}$ or $\overline{\text{CLR}}$	Q or $\bar{Q}$	1.2	4.1	6.5	1.2	7.5	ns
t <sub>PHL</sub>			1.2	4.1	6.5	1.2	7.5	

† For conditions shown as MIN or MAX, use the appropriate value specified under recommended operating conditions.

NOTE 3: Load circuits and waveforms are shown in Section 1.

8961723 0096368 924



POST OFFICE BOX 855303 • DALLAS, TEXAS 75265