



3.3V CMOS HEX SCHMITT-TRIGGER INVERTER WITH 5 VOLT TOLERANT I/O

IDT74LVC14A

FEATURES:

- 0.5 MICRON CMOS Technology
- ESD > 2000V per MIL-STD-883, Method 3015; > 200V using machine model (C = 200pF, R = 0)
- Vcc = 3.3V ± 0.3V, Normal Range
- Vcc = 2.7V to 3.6V, Extended Range
- CMOS power levels (0.4µ W typ. static)
- Rail-to-Rail output swing for increased noise margin
- All inputs, outputs, and I/Os are 5V tolerant
- Supports hot insertion
- Available in SOIC, SSOP, and TSSOP packages

DRIVE FEATURES:

- High Output Drivers: ±24mA
- Reduced system switching noise

DESCRIPTION:

The LVC14A Hex Schmitt-trigger inverter is built using advanced dual metal CMOS technology. This device contains six independent inverters and performs the Boolean function $Y = \bar{A}$.

Inputs can be driven from either 3.3V or 5V devices. This feature allows the use of this device as a translator in a mixed 3.3V/5V supply system.

The LVC14A has been designed with a ±24mA output driver. This driver is capable of driving a moderate to heavy load while maintaining speed performance.

APPLICATIONS:

- 5V and 3.3V mixed voltage systems
- Data communication and telecommunication systems

FUNCTIONAL BLOCK DIAGRAM

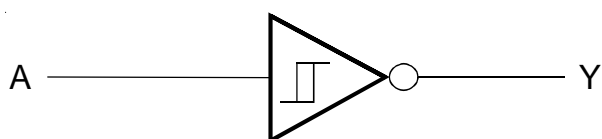

PIN CONFIGURATION

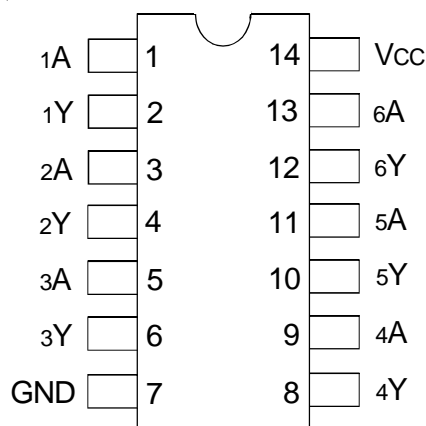

SOIC/ SSOP/ TSSOP
TOP VIEW

PIN DESCRIPTION

Pin Names	Description
x A	Inputs
x Y	Outputs

FUNCTION TABLE (EACH INVERTER)⁽¹⁾

Inputs	Outputs
x A	x Y
H	L
L	H

NOTE:

1. H = HIGH Voltage Level
L = LOW Voltage Level

ABSOLUTE MAXIMUM RATINGS⁽¹⁾

Symbol	Description	Max	Unit
V _{TERM}	Terminal Voltage with Respect to GND	-0.5 to +6.5	V
T _{STG}	Storage Temperature	-65 to +150	°C
I _{OUT}	DC Output Current	-50 to +50	mA
I _{IK} I _{OK}	Continuous Clamp Current, V _I < 0 or V _O < 0	-50	mA
I _{CC} I _{SS}	Continuous Current through each V _{CC} or GND	±100	mA

NOTE:

1. Stresses greater than those listed under ABSOLUTE MAXIMUM RATINGS may cause permanent damage to the device. This is a stress rating only and functional operation of the device at these or any other conditions above those indicated in the operational sections of this specification is not implied. Exposure to absolute maximum rating conditions for extended periods may affect reliability.

CAPACITANCE (T_A = +25°C, F = 1.0MHz)

Symbol	Parameter ⁽¹⁾	Conditions	Typ.	Max.	Unit
C _{IN}	Input Capacitance	V _{IN} = 0V	4.5	6	pF
C _{OUT}	Output Capacitance	V _{OUT} = 0V	5.5	8	pF
C _{I/O}	I/O Port Capacitance	V _{IN} = 0V	6.5	8	pF

NOTE:

1. As applicable to the device type.

DC ELECTRICAL CHARACTERISTICS OVER OPERATING RANGE

Following Conditions Apply Unless Otherwise Specified:

Operating Condition: T_A = -40°C to +85°C

Symbol	Parameter	Test Conditions	Min.	Typ. ⁽¹⁾	Max.	Unit
V _{IH}	Input HIGH Voltage Level	V _{CC} = 2.3V to 2.7V	1.7	—	—	V
		V _{CC} = 2.7V to 3.6V	2	—	—	
V _{IL}	Input LOW Voltage Level	V _{CC} = 2.3V to 2.7V	—	—	0.7	V
		V _{CC} = 2.7V to 3.6V	—	—	0.8	
I _{IH} I _{IL}	Input Leakage Current	V _{CC} = 3.6V V _I = 0 to 5.5V	—	—	±5	μA
I _{OFF}	Input/Output Power Off Leakage	V _{CC} = 0V, V _{IN} or V _O ≤ 5.5V	—	—	±50	μA
V _{IK}	Clamp Diode Voltage	V _{CC} = 2.3V, I _{IN} = -18mA	—	-0.7	-1.2	V
I _{CC} I _{CH}	Quiescent Power Supply Current	V _{CC} = 3.6V, V _{IN} = GND or V _{CC}	—	—	10	μA
ΔI _{CC}	Quiescent Power Supply Current Variation	One input at V _{CC} - 0.6V, other inputs at V _{CC} or GND	—	—	500	μA

NOTE:

1. Typical values are at V_{CC} = 3.3V, +25°C ambient.

OUTPUT DRIVE CHARACTERISTICS

Symbol	Parameter	Test Conditions ⁽¹⁾		Min.	Max.	Unit
VOH	Output HIGH Voltage	VCC = 2.3V to 3.6V	IOH = - 0.1mA	VCC - 0.2	—	V
		VCC = 2.3V	IOH = - 6mA	2	—	
		VCC = 2.3V	IOH = - 12mA	1.7	—	
		VCC = 2.7V		2.2	—	
		VCC = 3V		2.4	—	
		VCC = 3V	IOH = - 24mA	2.2	—	
VOL	Output LOW Voltage	VCC = 2.3V to 3.6V	IOL = 0.1mA	—	0.2	V
		VCC = 2.3V	IOL = 6mA	—	0.4	
			IOL = 12mA	—	0.7	
		VCC = 2.7V	IOL = 12mA	—	0.4	
		VCC = 3V	IOL = 24mA	—	0.55	

NOTE:
1. VIH and VIL must be within the min. or max. range shown in the DC ELECTRICAL CHARACTERISTICS OVER OPERATING RANGE table for the appropriate VCC range.
TA = - 40°C to + 85°C.

HYSTERESIS CHARACTERISTICS

Parameter	Test Conditions	VCC	Min.	Typ.	Max.	Unit
VT+ Positive-going threshold	Input Voltage, from VIL to VIH, in a linear ramp observing the output transition.	2.7V	0.8		2	V
		3V	0.8		2	
		3.6V	0.8		2	
VT+ Negative-going threshold	Input Voltage, from VIH to VIL, in a linear ramp observing the output transition.	2.7V	0.4		1.4	V
		3V	0.6		1.5	
		3.6V	0.8		1.8	
ΔVT Hysteresis (VT+ - VT-)	$\Delta V_{T \min} = V_{T+ \min} - V_{T- \max} $ $\Delta V_{T \max} = V_{T+ \max} - V_{T- \min} $	2.7V	0.3		1.1	V
		3V	0.3		1.2	
		3.6V	0.3		1.2	

OPERATING CHARACTERISTICS, VCC = 3.3V ± 0.3V, TA = 25°C

Symbol	Parameter	Test Conditions	Typical	Unit
CPD	Power Dissipation Capacitance per Inverter	CL = 0pF, f = 10Mhz	7	pF

SWITCHING CHARACTERISTICS⁽¹⁾

Symbol	Parameter	VCC = 2.7V		VCC = 3.3V ± 0.3V		Unit
		Min.	Max.	Min.	Max.	
tPLH	Propagation Delay	—	7.5	1	6.4	ns
tPHL	xA to xY					
tsk(0)	Output Skew ⁽²⁾	—	—	—	1	ns

NOTES:
1. See TEST CIRCUITS AND WAVEFORMS. TA = - 40°C to + 85°C.
2. Skew between any two outputs of the same package and switching in the same direction.

TEST CIRCUITS AND WAVEFORMS
TEST CONDITIONS

Symbol	V _{CC} ⁽¹⁾ = 2.5V ± 0.2V	V _{CC} ⁽²⁾ = 3.3V ± 0.3V & 2.7V	Unit
V _{LOAD}	2 x V _{CC}	6	V
V _{IH}	V _{CC}	2.7	V
V _T	V _{CC} / 2	1.5	V
V _{LZ}	150	300	mV
V _{HZ}	150	300	mV
C _L	30	50	pF

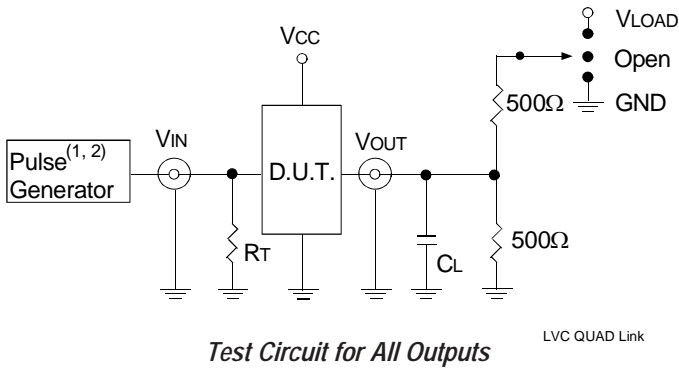

DEFINITIONS:

C_L = Load capacitance: includes jig and probe capacitance.
R_T = Termination resistance: should be equal to Z_{out} of the Pulse Generator.

NOTES:

1. Pulse Generator for All Pulses: Rate ≤ 10MHz; t_r ≤ 2ns; t_r ≤ 2ns.
2. Pulse Generator for All Pulses: Rate ≤ 10MHz; t_r ≤ 2.5ns; t_r ≤ 2.5ns.

SWITCH POSITION

Test	Switch
Open Drain Disable Low Enable Low	V _{LOAD}
Disable High Enable High	GND
All Other Tests	Open

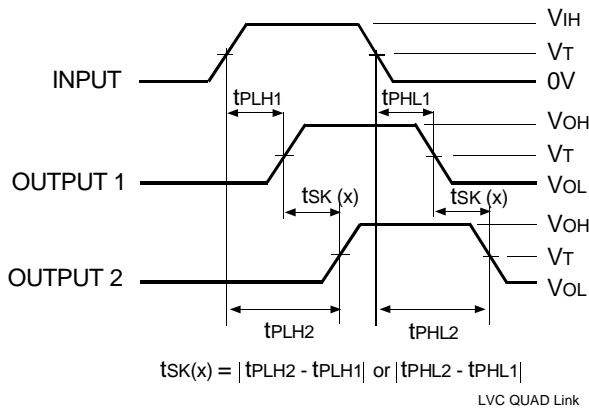

NOTES:

1. For tsk(o) OUTPUT1 and OUTPUT2 are any two outputs.
2. For tsk(b) OUTPUT1 and OUTPUT2 are in the same bank.

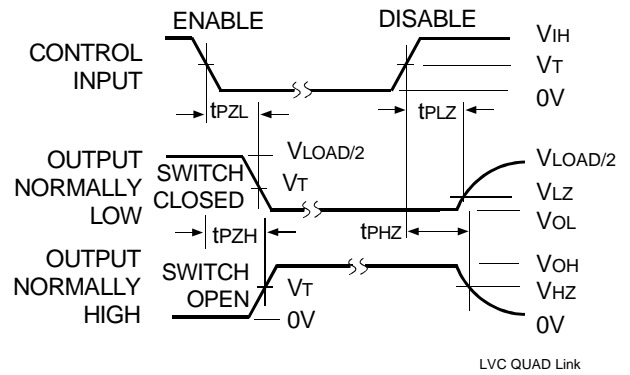
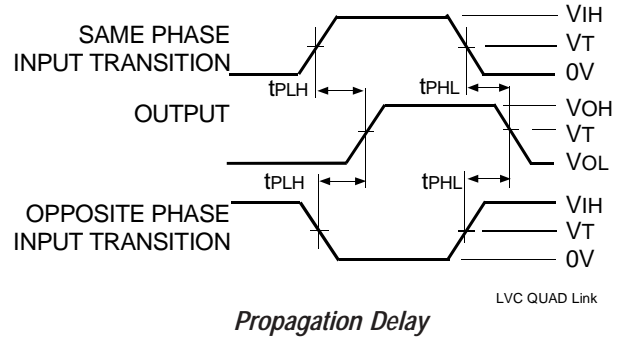

NOTE:

1. Diagram shown for input Control Enable-LOW and input Control Disable-HIGH.

Enable and Disable Times

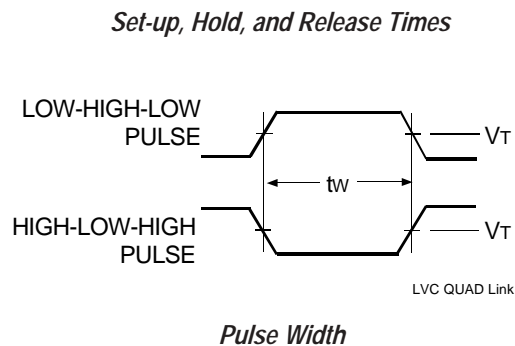
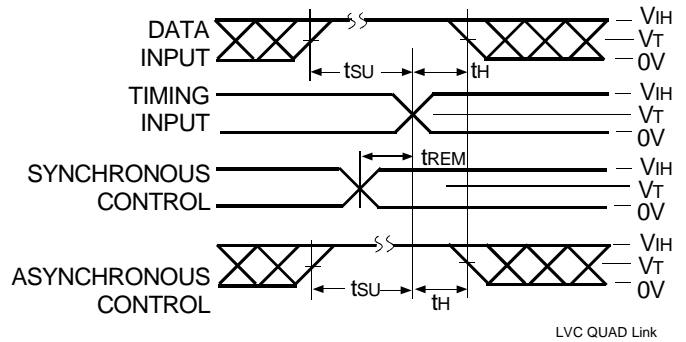

ORDERING INFORMATION

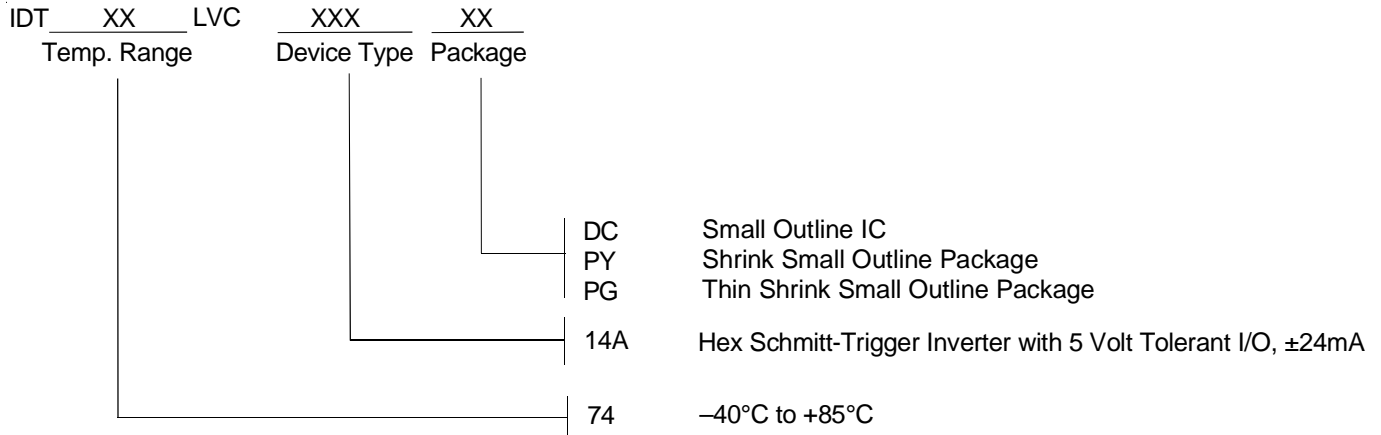

CORPORATE HEADQUARTERS
2975 Stender Way
Santa Clara, CA 95054

for SALES:
800-345-7015 or 408-727-6116
fax: 408-492-8674
www.idt.com

for Tech Support:
logichelp@idt.com
(408) 654-6459