



DATA SHEET

1F1G~1F7G

GLASS PASSIVATED JUNCTION FAST RECOVERY RECTIFIERS

VOLTAGE 50 to 1000 Volts **CURRENT** 1.0 Amperes

R-1 Unit: inch(mm)

FEATURES

- High current capability.
- Plastic package has Underwriters Laboratories Flammability Classification 94V-O utilizing Flame Retardant Epoxy Molding Compound.
- Low leakage.
- Fast switching for high efficiency.
- Exceeds environmental standards of MIL-S-19500/228
- Pb free product are available : 99% Sn above can meet Rohs environment substance directive request

MECHANICAL DATA

Case: Molded plastic, R-1
 Terminals: Axial leads, solderable per MIL-STD-202G, Method 208
 Polarity: Band denotes cathode
 Mounting Position: Any
 Weight: 0.0064 ounce, 0.181 gram

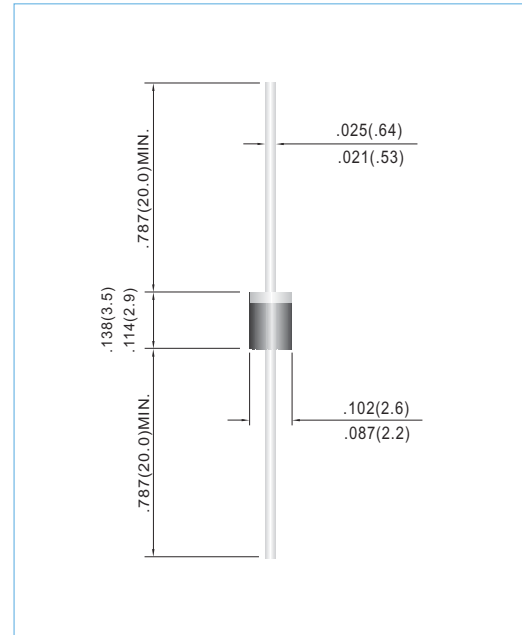

MAXIMUM RATINGS AND ELECTRICAL CHARACTERISTICS

Ratings at 25°C ambient temperature unless otherwise specified. Resistive or inductive load, 60Hz.

PARAMETER	SYMBOL	1F1G	1F2G	1F3G	1F4G	1F5G	1F6G	1F7G	UNITS
Maximum Recurrent Peak Reverse Voltage	V_{RRM}	50	100	200	400	600	800	1000	V
Maximum RMS Voltage	V_{RMS}	35	70	140	280	420	560	700	V
Maximum DC Blocking Voltage	V_{DC}	50	100	200	400	600	800	1000	V
Maximum Average Forward Current .375"(9.5mm) lead length at $T_A=55^\circ\text{C}$	I_{AV}	1.0							A
Peak Forward Surge Current : 8.3 ms single half sine-wave superimposed on rated load(JEDEC method)	I_{FSM}	30							A
Maximum Forward Voltage at 1.0A	V_F	1.3							V
Maximum DC Reverse Current $T_A=25^\circ\text{C}$ at Rated DC Blocking Voltage $T_A=100^\circ\text{C}$	I_R	5.0 150							μA
Typical Junction capacitance (Note 1)	C_J	12							pF
Maximum Reverse Recovery Time	T_{RR}	150					250	500	ns
Typical Thermal Resistance	$R_{\theta JA}$	67							$^\circ\text{C} / \text{W}$
Operating Junction and Storage Temperature Range	T_J, T_{STG}	-55 TO +150							$^\circ\text{C}$

NOTES: 1. Reverse Recovery Test Conditions: $I_F=.5\text{A}$, $I_R=1\text{A}$, $I_{rr}=.25\text{A}$
 2. Measured at 1 MHz and applied reverse voltage of 4.0 VDC
 3. Thermal resistance from junction to ambient and from junction to lead length 0.375"(9.5mm) P.C.B. mounted with 0.22 x 0.22" (5.5 x 5.5mm) copper pads.



RATING AND CHARACTERISTIC CURVES

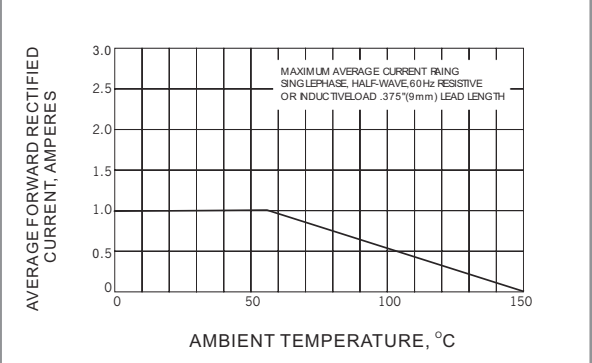

Fig.1 FORWARD CURRENT DERATING CURVE

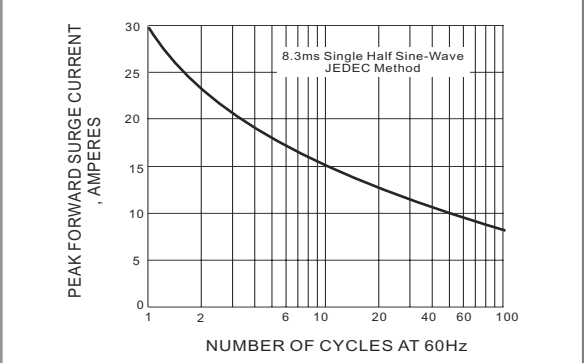

Fig.2-MAXIMUM NON-REPETITIVE PEAK FORWARD SURGE CURRENT

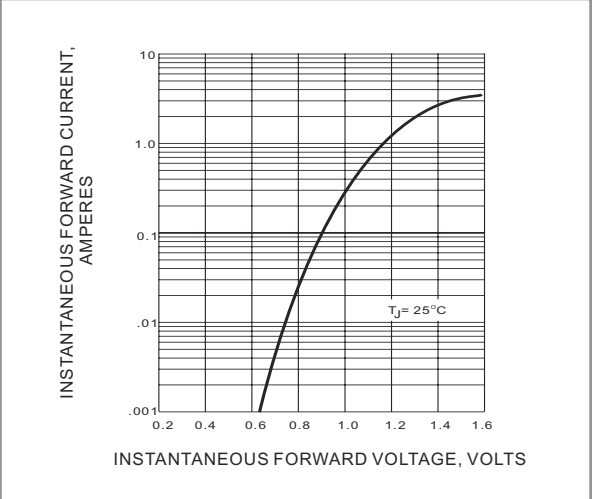

Fig.3-TYPICAL INSTANTANEOUS FORWARD CHARACTERISTICS

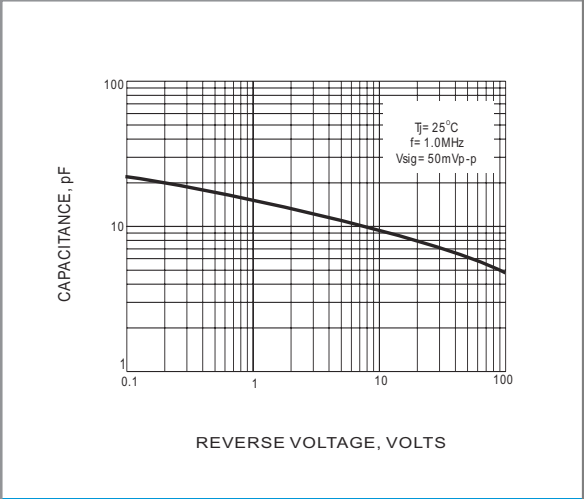

Fig.4 TYPICAL JUNCTION CAPACITANCE