

**74VHC4051**  
**8-Channel Analog Multiplexer**  
**74VHC4052**  
**Dual 4-Channel Analog Multiplexer**  
**74VHC4053**  
**Triple 2-Channel Analog Multiplexer**

### General Description

These multiplexers are digitally controlled analog switches implemented in advanced silicon-gate CMOS technology. These switches have low "on" resistance and low "off" leakages. They are bidirectional switches, thus any analog input may be used as an output and vice-versa. Also these switches contain linearization circuitry which lowers the on resistance and increases switch linearity. These devices allow control of up to  $\pm 6V$  (peak) analog signals with digital control signals of 0 to 6V. Three supply pins are provided for  $V_{CC}$ , ground, and  $V_{EE}$ . This enables the connection of 0–5V logic signals when  $V_{CC}=5V$  and an analog input range of  $\pm 5V$  when  $V_{EE}=5V$ . All three devices also have an inhibit control which when high will disable all switches to their off state. All analog inputs and outputs and digital inputs are protected from electrostatic damage by diodes to  $V_{CC}$  and ground.

**74VHC4051:** This device connects together the outputs of 8 switches, thus achieving an 8 channel Multiplexer. The binary code placed on the A, B, and C select lines determines which one of the eight switches is "on", and connects one of the eight inputs to the common output.

**74VHC4052:** This device connects together the outputs of 4 switches in two sets, thus achieving a pair of 4-channel

multiplexers. The binary code placed on the A, and B select lines determine which switch in each 4 channel section is "on", connecting one of the four inputs in each section to its common output. This enables the implementation of a 4-channel differential multiplexer.

**74VHC4053:** This device contains 6 switches whose outputs are connected together in pairs, thus implementing a triple 2 channel multiplexer, or the equivalent of 3 single-pole-double throw configurations. Each of the A, B, or C select lines independently controls one pair of switches, selecting one of the two switches to be "on".

### Features

- Wide analog input voltage range:  $\pm 6V$
- Low "on" resistance: 50 typ. ( $V_{CC}-V_{EE}=4.5V$ )  
30 typ. ( $V_{CC}-V_{EE}=9V$ )
- Logic level translation to enable 5V logic with  $\pm 5V$  analog signals
- Low quiescent current: 80  $\mu A$  maximum
- Matched Switch characteristic
- Pin and function compatible with the 74HC4051/4052/4053

**Ordering Code:** See Section 6

Commercial	Package Number	Package Description
74VHC4051M	M16A	16-Lead Molded JEDEC SOIC (0.150" Wide)
74VHC4051WM	M16B	16-Lead Molded JEDEC SOIC (0.300" Wide)
74VHC4051N	N16E	16-Lead Molded DIP
74VHC4052M	M16A	16-Lead Molded JEDEC SOIC (0.150" Wide)
74VHC4052WM	M16B	16-Lead Molded JEDEC SOIC (0.300" Wide)
74VHC4052N	N16E	16-Lead Molded DIP
74VHC4053M	M16A	16-Lead Molded JEDEC SOIC (0.150" Wide)
74VHC4053WM	M16B	16-Lead Molded JEDEC SOIC (0.300" Wide)
74VHC4053N	N16E	16-Lead Molded DIP

**Note:** Surface mount packages are also available on Tape and Reel. Specify by appending the suffix letter "X" to the ordering code.

### Connection Diagrams

### Truth Tables

Pin Assignments for SOIC and PDIP

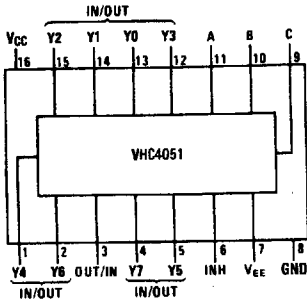

Top View

TL/F/11674-1

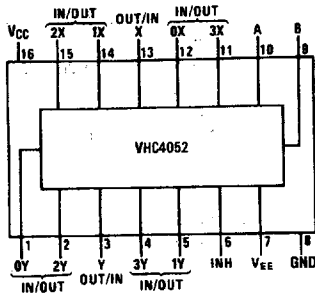

Top View

TL/F/11674-2

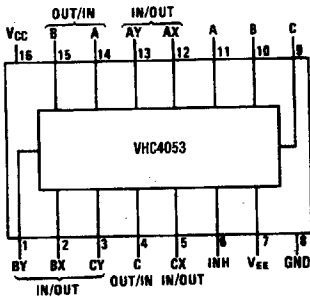

Top View

TL/F/11674-3

'4051

Inh	Input			"ON" Channel
	C	B	A	
H	X	X	X	None
L	L	L	L	Y0
L	L	L	H	Y1
L	L	H	L	Y2
L	L	H	H	Y3
L	H	L	L	Y4
L	H	L	H	Y5
L	H	H	L	Y6
L	H	H	H	Y7

'4052

Inh	Inputs		"ON" Channels	
	B	A	X	Y
H	X	X	None	None
L	L	L	0X	0Y
L	L	H	1X	1Y
L	H	L	2X	2Y
L	H	H	3X	3Y

'4053

Inh	Input			"ON" Channels		
	C	B	A	C	b	a
H	X	X	X	None	None	None
L	L	L	L	CX	BX	AX
L	L	L	H	CX	BX	AY
L	L	H	L	CX	BY	AX
L	L	H	H	CX	BY	AY
L	H	L	L	CY	BX	AX
L	H	L	H	CY	BX	AY
L	H	H	L	CY	BY	AX
L	H	H	H	CY	BY	AY

# Logic Diagrams

4051 / 4052 / 4053

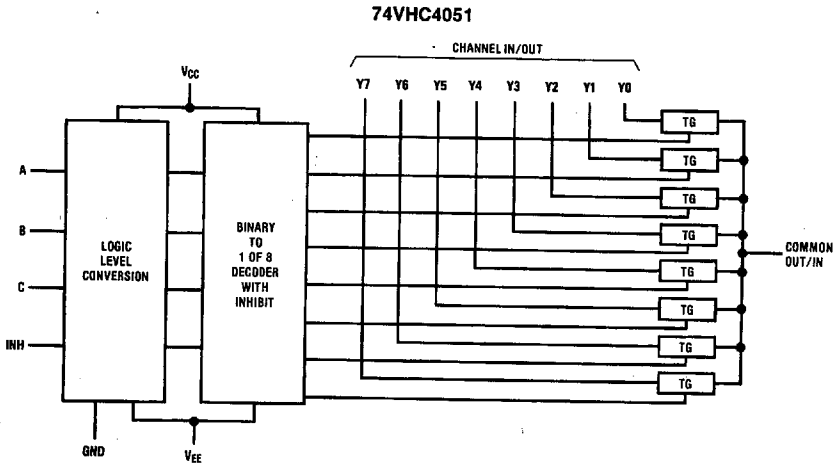

TL/F/11674-12

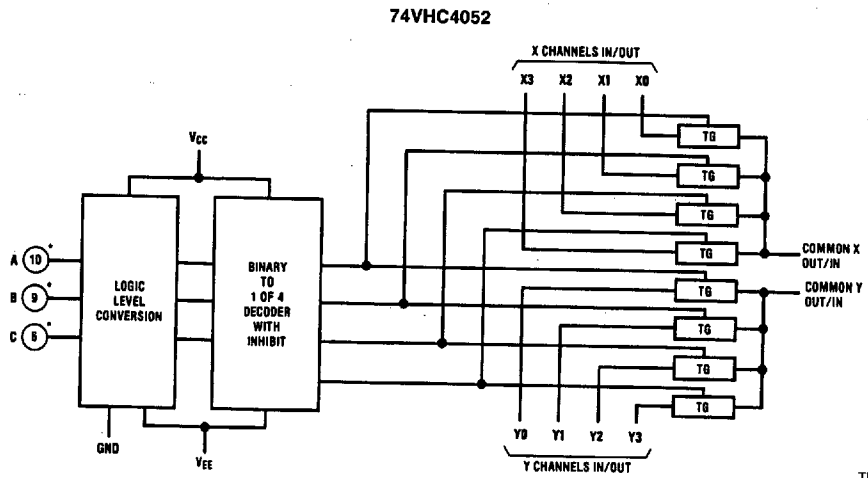

TL/F/11674-13

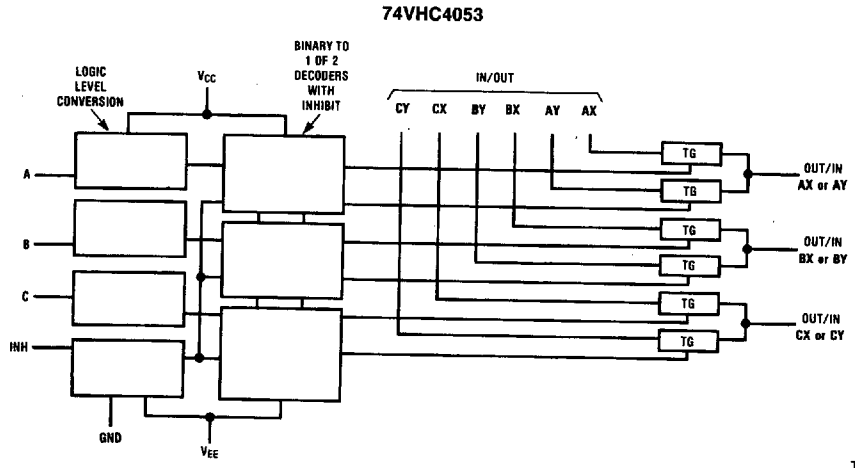

TL/F/11674-14

### Absolute Maximum Ratings (Notes 1 & 2)

Supply Voltage (V <sub>CC</sub> )	-0.5 to +7.5V
Supply Voltage (V <sub>EE</sub> )	+0.5 to -7.5V
Control Input Voltage (V <sub>IN</sub> )	-1.5 to V <sub>CC</sub> +1.5V
Switch I/O Voltage (V <sub>IO</sub> )	V <sub>EE</sub> -0.5 to V <sub>CC</sub> +0.5V
Clamp Diode Current (I <sub>IK</sub> , I <sub>OK</sub> )	±20 mA
Output Current, per pin (I <sub>OUT</sub> )	±25 mA
V <sub>CC</sub> or GND Current, per pin (I <sub>CC</sub> )	±50 mA
Storage Temperature Range (T <sub>STG</sub> )	-65°C to +150°C
Power Dissipation (P <sub>D</sub> ) (Note 3)	600 mW
S.O. Package only	500 mW
Lead Temp. (T <sub>L</sub> ) (Soldering 10 seconds)	260°C

### Operating Conditions

	Min	Max	Units
Supply Voltage (V <sub>CC</sub> )	2	6	V
Supply Voltage (V <sub>EE</sub> )	0	-6	V
DC Input or Output Voltage (V <sub>IN</sub> , V <sub>OUT</sub> )	0	V <sub>CC</sub>	V
Operating Temp. Range (T <sub>A</sub> ) 74VHC	-40	+85	°C
Input Rise or Fall Times (t <sub>r</sub> , t <sub>f</sub> )	V <sub>CC</sub> =2.0V	1000	ns
	V <sub>CC</sub> =4.5V	500	ns
	V <sub>CC</sub> =6.0V	400	ns

### DC Electrical Characteristics (Note 4)

Symbol	Parameter	Conditions	V <sub>EE</sub>	V <sub>CC</sub>	T <sub>A</sub> = 25°C		74VHC T <sub>A</sub> = -40 to 85°C		Units
					Typ	Guaranteed Limits			
V <sub>IH</sub>	Minimum High Level Input Voltage			2.0V	1.5	1.5	V		
				4.5V	3.15	3.15	V		
				6.0V	4.2	4.2	V		
V <sub>IL</sub>	Maximum Low Level Input Voltage			2.0V	0.5	0.5	V		
				4.5V	1.35	1.35	V		
				6.0V	1.8	1.8	V		
R <sub>ON</sub>	Maximum "ON" Resistance (Note 5)	V <sub>INH</sub> = V <sub>IL</sub> , I <sub>S</sub> = 2.0 mA V <sub>IS</sub> = V <sub>CC</sub> to V <sub>EE</sub> (Figure 1)	GND	4.5V	40	160	200	Ω	
			-4.5V	4.5V	30	120	150	Ω	
			-6.0V	6.0V	20	100	125	Ω	
		V <sub>INH</sub> = V <sub>IL</sub> , I <sub>S</sub> = 2.0 mA V <sub>IS</sub> = V <sub>CC</sub> or V <sub>EE</sub> (Figure 1)	GND	2.0V	100	230	280	Ω	
			GND	4.5V	40	110	140	Ω	
			-4.5V	4.5V	20	90	120	Ω	
-6.0V	6.0V	15	80	100	Ω				
R <sub>ON</sub>	Maximum "ON" Resistance Matching	V <sub>CTL</sub> = V <sub>IL</sub> V <sub>IS</sub> = V <sub>CC</sub> to GND	GND	4.5V	10	20	25	Ω	
			-4.5V	4.5V	5	10	15	Ω	
			-6.0V	6.0V	5	10	12	Ω	
I <sub>N</sub>	Maximum Control Input Current	V <sub>IN</sub> = V <sub>CC</sub> or GND V <sub>CC</sub> = 2-6V				±.05	±0.5	μA	
I <sub>CC</sub>	Maximum Quiescent Supply Current	V <sub>IN</sub> = V <sub>CC</sub> or GND I <sub>OUT</sub> = 0 μA	GND	6.0V		4	40	μA	
			-6.0V	6.0V		8	80	μA	
I <sub>IZ</sub>	Maximum Switch "OFF" Leakage Current (Switch Input)	V <sub>OS</sub> = V <sub>CC</sub> or V <sub>EE</sub> V <sub>IS</sub> = V <sub>EE</sub> or V <sub>CC</sub> V <sub>INH</sub> = V <sub>IH</sub> (Figure 2)	GND	6.0V		±60	±300	nA	
			-6.0V	6.0V		±100	±500	nA	
I <sub>IZ</sub>	Maximum Switch "ON" Leakage Current	V <sub>IS</sub> = V <sub>CC</sub> to V <sub>EE</sub> V <sub>INH</sub> = V <sub>IL</sub> (Figure 3)	GND	6.0V		±0.1	±1.0	μA	
			-6.0V	6.0V		±0.2	±2.0	μA	
			VHC4051						
		V <sub>IS</sub> = V <sub>CC</sub> to V <sub>EE</sub> V <sub>INH</sub> = V <sub>IL</sub> (Figure 3)	GND	6.0V		±0.050	±0.5	μA	
-6.0V	6.0V			±0.1	±1.0	μA			
VHC4052									
		V <sub>IS</sub> = V <sub>CC</sub> to V <sub>EE</sub> V <sub>INH</sub> = V <sub>IL</sub> (Figure 3)	GND	6.0V		±0.05	±0.5	μA	
-6.0V	6.0V			±0.5	±0.5	μA			
VHC4053									

## DC Electrical Characteristics (Note 4) (Continued)

Symbol	Parameter		Conditions	V <sub>EE</sub>	V <sub>CC</sub>	T <sub>A</sub> = 25°C		74VHC T <sub>A</sub> = -40 to 85°C		Units	
						Typ	Guaranteed Limits				
I <sub>IZ</sub>	Maximum Switch "OFF" Leakage Current (Common Pin)	VHC4051	V <sub>OS</sub> = V <sub>CC</sub> or V <sub>EE</sub> V <sub>IS</sub> = V <sub>EE</sub> or V <sub>CC</sub> V <sub>INH</sub> = V <sub>IH</sub>	GND -6.0V	6.0V 6.0V		±0.1 ±0.2	±1.0 ±2.0	μA μA		
		VHC4052	V <sub>OS</sub> = V <sub>CC</sub> or V <sub>EE</sub> V <sub>IS</sub> = V <sub>EE</sub> or V <sub>CC</sub> V <sub>INH</sub> = V <sub>IH</sub>	GND -6.0V	6.0V 6.0V		±0.05 ±0.1	±0.5 ±1.0	μA μA		
		VHC4053	V <sub>OS</sub> = V <sub>CC</sub> or V <sub>EE</sub> V <sub>IS</sub> = V <sub>EE</sub> or V <sub>CC</sub> V <sub>INH</sub> = V <sub>IH</sub>	GND -6.0V	6.0V 6.0V		±0.05 ±0.05	±0.5 ±0.5	μA μA		

**Note 1:** Absolute Maximum Ratings are those values beyond which damage to the device may occur.

**Note 2:** Unless otherwise specified all voltages are referenced to ground.

**Note 3:** Power Dissipation temperature derating — plastic "N" package: -12 mW/°C from 65°C to 85°C.

**Note 4:** For a power supply of 5V ±10% the worst case on resistances (R<sub>ON</sub>) occurs for VHC at 4.5V. Thus the 4.5V values should be used when designing with this supply. Worst case V<sub>IH</sub> and V<sub>IL</sub> occur at V<sub>CC</sub> = 5.5V and 4.5V respectively. (The V<sub>IH</sub> value at 5.5V is 3.85V.) The worst case leakage current occur for CMOS at the higher voltage and so the 5.5V values should be used.

**Note 5:** At supply voltages (V<sub>CC</sub>-V<sub>EE</sub>) approaching 2V the analog switch on resistance becomes extremely non-linear. Therefore it is recommended that these devices be used to transmit digital only when using these supply voltages.

**Note 6:** Adjust 0 dB for f = 1 kHz (Null R1/R<sub>ON</sub> Attenuation).

## AC Electrical Characteristics V<sub>CC</sub> = 2.0V-6.0V, V<sub>EE</sub> = 0V-6V, C<sub>L</sub> = 50 pF (unless otherwise specified)

Symbol	Parameter		Conditions	V <sub>EE</sub>	V <sub>CC</sub>	T <sub>A</sub> = 25°C		74VHC T <sub>A</sub> = -40 to 85°C		Units	
						Typ	Guaranteed Limits				
t <sub>PHL</sub> , t <sub>PLH</sub>	Maximum Propagation Delay Switch In to Out			GND	3.3V	25	35	40	ns		
				GND	4.5V	5	12	15	ns		
				-4.5V	4.5V	4	8	12	ns		
				-6.0V	6.0V	3	7	11	ns		
t <sub>PZL</sub> , t <sub>PZH</sub>	Maximum Switch Turn "ON" Delay	R <sub>L</sub> = 1 kΩ		GND	3.3V	92	200	250	ns		
				GND	4.5V		69	87	ns		
				-4.5V	4.5V	16	46	58	ns		
				-6.0V	6.0V	15	41	51	ns		
t <sub>PHZ</sub> , t <sub>PLZ</sub>	Maximum Switch Turn "OFF" Delay			GND	3.3V	65	170	210	ns		
				GND	4.5V	28	58	73	ns		
				-4.5V	4.5V	18	37	46	ns		
				-6.0V	6.0V	16	32	41	ns		
f <sub>MAX</sub>	Minimum Switch Frequency Response 20 log (V <sub>I</sub> /V <sub>O</sub> ) = 3 dB			GND	4.5V	30			MHz		
				-4.5V	4.5V	35			MHz		
	Control to Switch Feedthrough Noise	R <sub>L</sub> = 600Ω, f = 1 MHz, C <sub>L</sub> = 50 pF	V <sub>IS</sub> = 4 V <sub>PP</sub> V <sub>IS</sub> = 8 V <sub>PP</sub>	0V	4.5V	1080			mV		
-4.5V				4.5V	250			mV			
	Crosstalk between any Two Switches	R <sub>L</sub> = 600Ω, f = 1 MHz	V <sub>IS</sub> = 4 V <sub>PP</sub> V <sub>IS</sub> = 8 V <sub>PP</sub>	0V	4.5	-52			dB		
-4.5V				4.5V	-50			dB			
	Switch OFF Signal Feedthrough Isolation	R <sub>L</sub> = 600Ω, f = 1 MHz, V <sub>CTL</sub> = V <sub>IL</sub>	V <sub>IS</sub> = 4 V <sub>PP</sub> V <sub>IS</sub> = 8 V <sub>PP</sub>	0V	4.5V	-42			dB		
-4.5V				4.5V	-44			dB			
THD	Sinewave Harmonic Distortion	R <sub>L</sub> = 10 kΩ, C <sub>L</sub> = 50 pF, f = 1 kHz	V <sub>IS</sub> = 4 V <sub>PP</sub> V <sub>IS</sub> = 8 V <sub>PP</sub>	0V	4.5V	0.013			%		
				-4.5V	4.5V	0.008			%		

# AC Electrical Characteristics

$V_{CC} = 2.0V - 6.0V$ ,  $V_{EE} = 0V - 6V$ ,  $C_L = 50 \text{ pF}$  (unless otherwise specified) (Continued)

Symbol	Parameter	Conditions	$V_{EE}$	$V_{CC}$	$T_A = 25^\circ\text{C}$		$74\text{VHC}$ $T_A = -40 \text{ to } 85^\circ\text{C}$		Units
					Typ	Guaranteed Limits			
$C_{IN}$	Maximum Control Input Capacitance				5	10	10		pF
$C_{IN}$	Maximum Switch Input Capacitance	Input 4051 Common 4052 Common 4053 Common			15 90 45 30				pF
$C_{IN}$	Maximum Feedthrough Capacitance				5				pF

## AC Test Circuits and Switching Time Waveforms

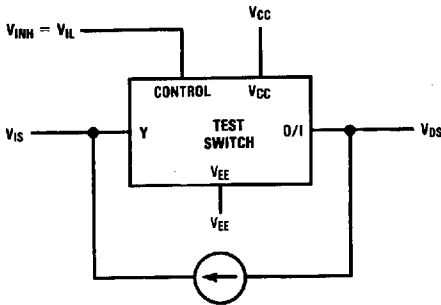

FIGURE 1. "ON" Resistance

TL/F/11674-4

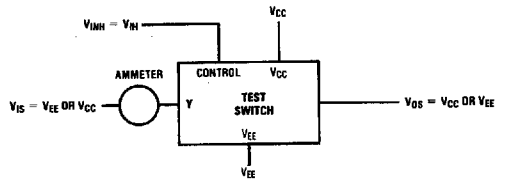

FIGURE 2. "OFF" Channel Leakage Current

TL/F/11674-5

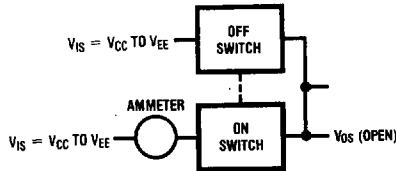

FIGURE 3. "ON" Channel Leakage Current

TL/F/11674-6

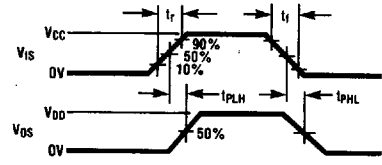
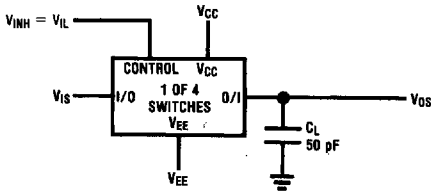

FIGURE 4.  $t_{PLH}$ ,  $t_{PLH}$  Propagation Delay Time Signal Input to Signal Output

TL/F/11674-7

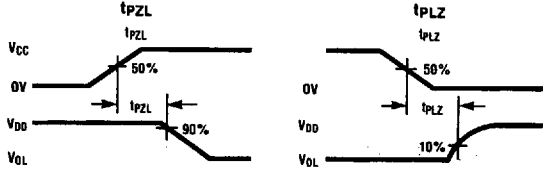
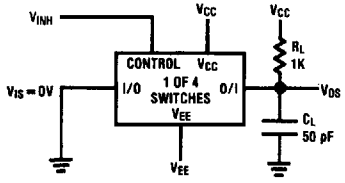

FIGURE 5.  $t_{PZL}$ ,  $t_{PLZ}$  Propagation Delay Time Control to Signal Output

TL/F/11674-8

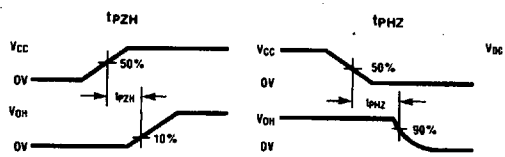
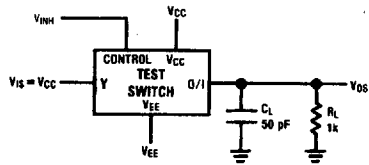

FIGURE 6.  $t_{PZH}$ ,  $t_{PHZ}$  Propagation Delay Time Control to Signal Output

TL/F/11674-9

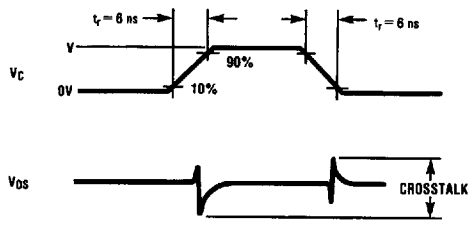
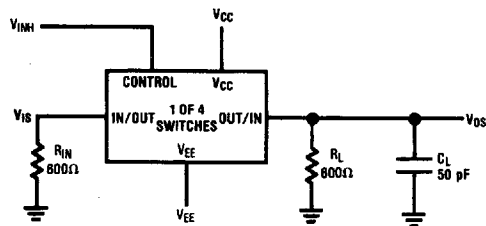

FIGURE 7. Crosstalk: Control Input to Signal Output

TL/F/11674-10

AC Test Circuits and Switching Time Waveforms (Continued)

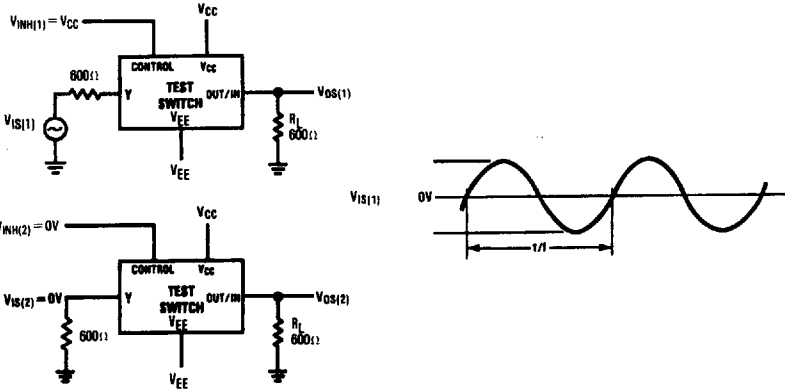
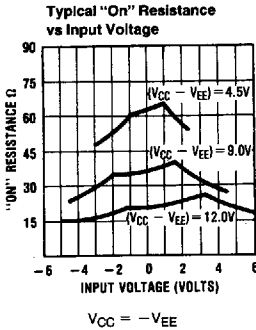

FIGURE 8. Crosstalk Between Any Two Switches

TL/F/11674-11

Typical Performance Characteristics



TL/F/11674-15

Special Considerations

In certain applications the external load-resistor current may include both  $V_{CC}$  and signal line components. To avoid drawing  $V_{CC}$  current when switch current flows into the analog switch pins, the voltage drop across the switch must not exceed 1.2V (calculated from the ON resistance).