

54F/74F533

Octal Transparent Latch with TRI-STATE® Outputs

General Description

The 'F533 consists of eight latches with TRI-STATE outputs for bus organized system applications. The flip-flops appear transparent to the data when Latch Enable (LE) is HIGH. When LE is LOW, the data that meets the setup times is latched. Data appears on the bus when the Output Enable ($\bar{O}E$) is LOW. When $\bar{O}E$ is HIGH the bus output is in the high impedance state. The 'F533 is the same as the 'F373, except that the outputs are inverted.

Features

- Eight latches in a single package
- TRI-STATE outputs for bus interfacing
- Inverted version of the 'F373
- Guaranteed 4000V minimum ESD protection

Ordering Code: See Section 11

Commercial	Military	Package Number	Package Description
74F533PC		N20A	20-Lead (0.300" Wide) Molded Dual-In-Line
	54F533DM (Note 2)	J20A	20-Lead Ceramic Dual-In-Line
74F533SC (Note 1)		M20B	20-Lead (0.300" Wide) Molded Small Outline, JEDEC
74F533SJ (Note 1)		M20D	20-Lead (0.300" Wide) Molded Small Outline, EIAJ
	54F533FM (Note 2)	W20A	20-Lead Cerpack
	54F533LM (Note 2)	E20A	20-Lead Ceramic Leadless Chip Carrier, Type C

Note 1: Devices also available in 13" reel. Use suffix = SCX and SJX.

Note 2: Military grade device with environmental and burn-in processing. Use suffix = DMQB, FMQB and LMQB.

Logic Symbols

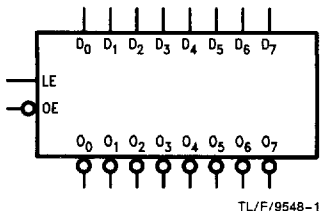
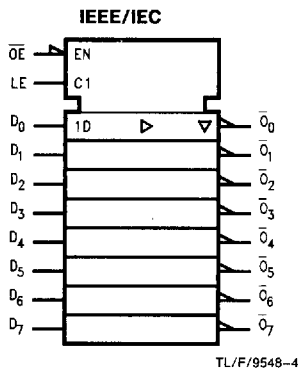

Connection Diagrams

Pin Assignment for DIP, SOIC and Flatpak

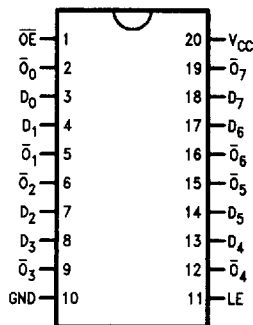

Pin Assignment for LCC

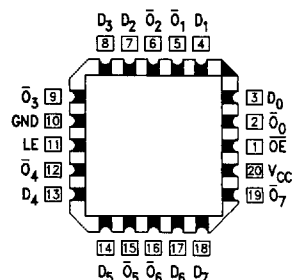

Unit Loading/Fan Out: See Section 2 for U.L. definitions

Pin Names	Description	54F/74F	
		U.L. HIGH/LOW	Input I_{IH}/I_{IL} Output I_{OH}/I_{OL}
D_0-D_7	Data Inputs	1.0/1.0	$20 \mu A / -0.6 \text{ mA}$
LE	Latch Enable Input (Active HIGH)	1.0/1.0	$20 \mu A / -0.6 \text{ mA}$
\overline{OE}	Output Enable Input (Active LOW)	1.0/1.0	$20 \mu A / -0.6 \text{ mA}$
$\overline{O}_0-\overline{O}_7$	Complementary TRI-STATE Outputs	150/40 (33.3)	$-3 \text{ mA} / 24 \text{ mA} (20 \text{ mA})$

Function Table

Inputs			Output
LE	\overline{OE}	D	\overline{O}
H	L	H	L
H	L	L	H
L	L	X	\overline{O}_0
X	H	X	Z

H = HIGH Voltage Level
 L = LOW Voltage Level
 X = Immaterial

Functional Description

The 'F533 contains eight D-type latches with TRI-STATE output buffers. When the Latch Enable (LE) input is HIGH, data on the D_n inputs enters the latches. In this condition the latches are transparent, i.e., a latch output will change state each time its D input changes. When LE is LOW, the latches store the information that was present on the D in-

puts a setup time preceding the HIGH-to-LOW transition of LE. The TRI-STATE buffers are controlled by the Output Enable (\overline{OE}) input. When \overline{OE} is LOW, the buffers are in the bi-state mode. When \overline{OE} is HIGH the buffers are in the high impedance mode but this does not interfere with entering new data into the latches.

Logic Diagram

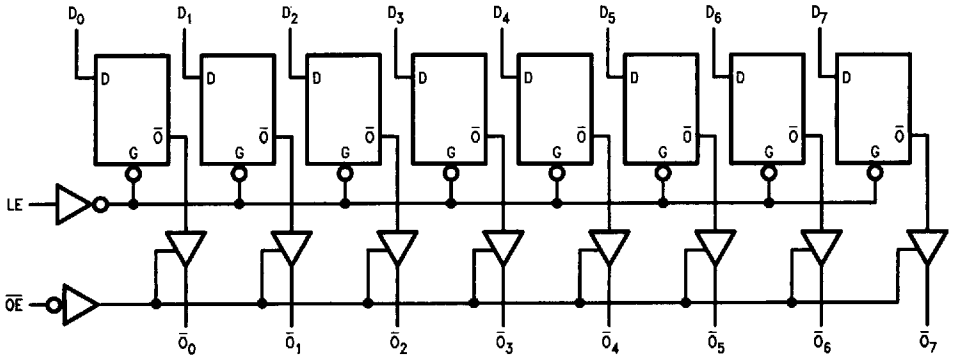

TL/F/9548-5

Please note that this diagram is provided only for the understanding of logic operations and should not be used to estimate propagation delays.

Absolute Maximum Ratings (Note 1)

If Military/Aerospace specified devices are required, please contact the National Semiconductor Sales Office/Distributors for availability and specifications.

Storage Temperature	-65°C to +150°C
Ambient Temperature under Bias	-55°C to +125°C
Junction Temperature under Bias	-55°C to +175°C
Plastic	-55°C to +150°C
V _{CC} Pin Potential to Ground Pin	-0.5V to +7.0V
Input Voltage (Note 2)	-0.5V to +7.0V
Input Current (Note 2)	-30 mA to +5.0 mA
Voltage Applied to Output in HIGH State (with V _{CC} = 0V)	
Standard Output	-0.5V to V _{CC}
TRI-STATE Output	-0.5V to +5.5V
Current Applied to Output in LOW State (Max)	twice the rated I _{OL} (mA)
ESD Last Passing Voltage (Min)	4000V

Note 1: Absolute maximum ratings are values beyond which the device may be damaged or have its useful life impaired. Functional operation under these conditions is not implied.

Note 2: Either voltage limit or current limit is sufficient to protect inputs.

Recommended Operating Conditions

Free Air Ambient Temperature	
Military	-55°C to +125°C
Commercial	0°C to +70°C
Supply Voltage	
Military	+4.5V to +5.5V
Commercial	+4.5V to +5.5V

DC Electrical Characteristics

Symbol	Parameter	54F/74F			Units	V _{CC}	Conditions
		Min	Typ	Max			
V _{IH}	Input HIGH Voltage	2.0			V		Recognized as a HIGH Signal
V _{IL}	Input LOW Voltage			0.8	V		Recognized as a LOW Signal
V _{CD}	Input Clamp Diode Voltage			-1.2	V	Min	I _{IN} = -18 mA
V _{OH}	Output HIGH Voltage	54F 10% V _{CC} 54F 10% V _{CC} 74F 10% V _{CC} 74F 10% V _{CC} 74F 5% V _{CC} 74F 5% V _{CC}	2.5 2.4 2.5 2.4 2.7 2.7		V	Min	I _{OH} = -1 mA I _{OH} = -3 mA I _{OH} = -1 mA I _{OH} = -3 mA I _{OH} = -1 mA I _{OH} = -3 mA
V _{OL}	Output LOW Voltage	54F 10% V _{CC} 74F 10% V _{CC}		0.5 0.5	V	Min	I _{OL} = 20 mA I _{OL} = 24 mA
I _{IH}	Input HIGH Current	54F 74F		20.0 5.0	μA	Max	V _{IN} = 2.7V
I _{BV1}	Input HIGH Current Breakdown Test	54F 74F		100 7.0	μA	Max	V _{IN} = 7.0V
I _{BVIT}	Input HIGH Current Breakdown (I/O)	54F 74F		1.0 0.5	mA	Max	V _{IN} = 5.5V
I _{CEX}	Output HIGH Leakage Current	54F 74F		250 50	μA	Max	V _{OUT} = V _{CC}
V _{ID}	Input Leakage Test	74F	4.75		V	0.0	I _{ID} = 1.9 μA All Other Pins Grounded
I _{OD}	Output Leakage Circuit Current	74F		3.75	μA	0.0	V _{IOD} = 150 mV All Other Pins Grounded
I _{IL}	Input LOW Current			-0.6	mA	Max	V _{IN} = 0.5V
I _{OZH}	Output Leakage Current			50	μA	Max	V _{OUT} = 2.7V
I _{OZL}	Output Leakage Current			-50	μA	Max	V _{OUT} = 0.5V
I _{OS}	Output Short-Circuit Current		-60	-150	mA	Max	V _{OUT} = 0V
I _{ZZ}	Bus Drainage Test			500	μA	0.0V	V _{OUT} = 5.25V
I _{CCZ}	Power Supply Current		41	61	mA	Max	V _O = HIGH Z

AC Electrical Characteristics: See Section 2 for Waveforms and Load Configurations

Symbol	Parameter	74F			54F		74F		Units	Fig. No.
		T _A = +25°C V _{CC} = +5.0V C _L = 50 pF			T _A , V _{CC} = Mil C _L = 50 pF		T _A , V _{CC} = Com C _L = 50 pF			
		Min	Typ	Max	Min	Max	Min	Max		
t _{PLH}	Propagation Delay	4.0	6.7	9.0	4.0	12.0	4.0	10.0	ns	2-3
t _{PHL}	D _n to \bar{O}_n	2.5	4.4	7.0	2.5	9.0	2.5	8.0		
t _{PLH}	Propagation Delay	5.0	7.1	11.0	5.0	14.0	5.0	13.0	ns	2-3
t _{PHL}	LE to \bar{O}_n	3.0	4.7	7.0	3.0	9.0	3.0	8.0		
t _{PZH}	Output Enable Time	2.0	5.9	10.0	2.0	12.5	2.0	11.0	ns	2-5
t _{PZL}		2.0	5.6	7.5	2.0	10.5	2.0	8.5		
t _{PHZ}	Output Disable Time	1.5	3.4	6.5	1.5	8.5	1.5	7.0	ns	2-5
t _{PLZ}		1.5	2.7	5.5	1.5	7.5	1.5	6.5		

AC Operating Requirements: See Section 2 for Waveforms

Symbol	Parameter	74F		54F		74F		Units	Fig. No.
		T _A = +25°C V _{CC} = +5.0V		T _A , V _{CC} = Mil		T _A , V _{CC} = Com			
		Min	Max	Min	Max	Min	Max		
t _s (H)	Setup Time, HIGH or LOW	2.0		2.0		2.0		ns	2-6
t _s (L)	D _n to LE	2.0		2.0		2.0			
t _h (H)	Hold Time, HIGH or LOW	3.0		3.0		3.0		ns	2-6
t _h (L)	D _n to LE	3.0		3.0		3.0			
t _w (H)	LE Pulse Width, HIGH	6.0		6.0		6.0		ns	2-4