

SN54ALS30A, SN54AS30, SN74ALS30A, SN74AS30 8-INPUT POSITIVE-NAND GATES

SDAS010B - MARCH 1984 - REVISED DECEMBER 1994

- Package Options Include Plastic Small-Outline (D) Packages, Ceramic Chip Carriers (FK), and Standard Plastic (N) and Ceramic (J) 300-mil DIPs

description

These devices contain an 8-input positive-NAND gate and perform the following Boolean functions in positive logic:

$$Y = \overline{A \cdot B \cdot C \cdot D \cdot E \cdot F \cdot G \cdot H}$$

$$Y = \overline{A} + \overline{B} + \overline{C} + \overline{D} + \overline{E} + \overline{F} + \overline{G} + \overline{H}$$

The SN54ALS30A and SN54AS30 are characterized for operation over the full military temperature range of -55°C to 125°C. The SN74ALS30A and SN74AS30 are characterized for operation from 0°C to 70°C.

FUNCTION TABLE

INPUTS A-H	OUTPUT Y
All inputs H	L
One or more inputs L	H

SN54ALS30A, SN54AS30 ... J PACKAGE
SN74ALS30A, SN74AS30 ... D OR N PACKAGE
(TOP VIEW)

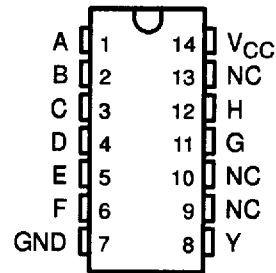

SN54ALS30A, SN54AS30 ... FK PACKAGE
(TOP VIEW)

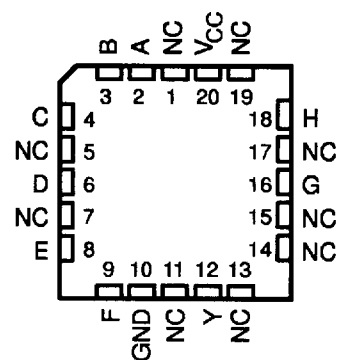

NC - No internal connection

logic symbol†

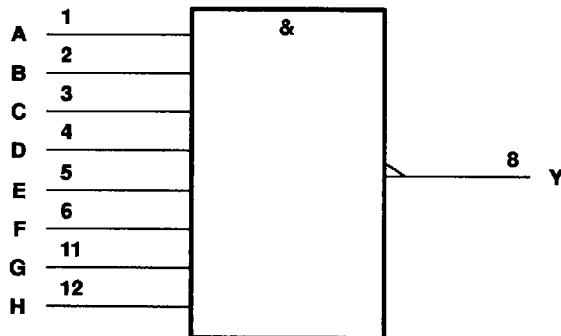

logic diagram (positive logic)

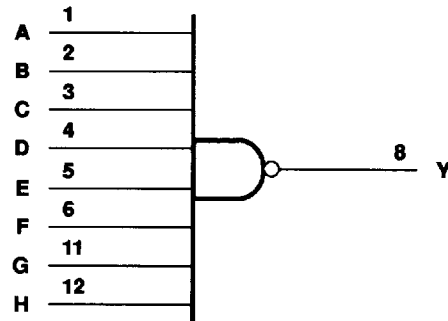

† This symbol is in accordance with ANSI/IEEE Std 91-1984 and IEC Publication 617-12.

Pin numbers shown are for the D, J, and N packages.

SN54ALS30A, SN54AS30, SN74ALS30A, SN74AS30 8-INPUT POSITIVE-NAND GATES

SDAS010B - MARCH 1984 - REVISED DECEMBER 1994

absolute maximum ratings over operating free-air temperature range (unless otherwise noted)†

Supply voltage, V_{CC}	7 V
Input voltage, V_I	7 V
Operating free-air temperature range, T_A : SN54ALS30A	-55°C to 125°C
SN74ALS30A	0°C to 70°C
Storage temperature range	-65°C to 150°C

† Stresses beyond those listed under "absolute maximum ratings" may cause permanent damage to the device. These are stress ratings only, and functional operation of the device at these or any other conditions beyond those indicated under "recommended operating conditions" is not implied. Exposure to absolute-maximum-rated conditions for extended periods may affect device reliability.

recommended operating conditions

		SN54ALS30A			SN74ALS30A			UNIT
		MIN	NOM	MAX	MIN	NOM	MAX	
V_{CC}	Supply voltage	4.5	5	5.5	4.5	5	5.5	V
V_{IH}	High-level input voltage	2			2			V
V_{IL}	Low-level input voltage			0.8‡			0.8	V
				0.7§				
I_{OH}	High-level output current			-0.4			-0.4	mA
I_{OL}	Low-level output current			4			8	mA
T_A	Operating free-air temperature	-55		125	0		70	°C

‡ Applies over temperature range -55°C to 70°C

§ Applies over temperature range 70°C to 125°C

electrical characteristics over recommended operating free-air temperature range (unless otherwise noted)

PARAMETER	TEST CONDITIONS	SN54ALS30A			SN74ALS30A			UNIT
		MIN	TYP†	MAX	MIN	TYP†	MAX	
V_{IK}	$V_{CC} = 4.5 V$, $I_I = -18 mA$			-1.5			-1.5	V
V_{OH}	$V_{CC} = 4.5 V$ to $5.5 V$, $I_{OH} = -0.4 mA$	$V_{CC} - 2$			$V_{CC} - 2$			V
V_{OL}	$V_{CC} = 4.5 V$	$I_{OL} = 4 mA$	0.25	0.4	0.25	0.4	V	
		$I_{OL} = 8 mA$			0.35	0.5		
I_I	$V_{CC} = 5.5 V$, $V_I = 7 V$		0.1			0.1	mA	
I_{IH}	$V_{CC} = 5.5 V$, $V_I = 2.7 V$		20			20	μA	
I_{IL}	$V_{CC} = 5.5 V$, $V_I = 0.4 V$		-0.1			-0.1	mA	
$I_O^{\#}$	$V_{CC} = 5.5 V$, $V_O = 2.25 V$	-20		-112	-30		-112	mA
I_{CCH}	$V_{CC} = 5.5 V$, $V_I = 0$		0.22	0.36		0.22	0.36	mA
I_{CCL}	$V_{CC} = 5.5 V$, $V_I = 4.5 V$		0.54	0.9		0.54	0.9	mA

† All typical values are at $V_{CC} = 5 V$, $T_A = 25^\circ C$.

The output conditions have been chosen to produce a current that closely approximates one half of the true short-circuit output current, I_{OS} .



POST OFFICE BOX 655303 • DALLAS, TEXAS 75265

8961723 0104385 984

SN54ALS30A, SN54AS30, SN74ALS30A, SN74AS30 8-INPUT POSITIVE-NAND GATES

SDAS010B - MARCH 1984 - REVISED DECEMBER 1994

switching characteristics (see Figure 1)

PARAMETER	FROM (INPUT)	TO (OUTPUT)	V _{CC} = 4.5 V to 5.5 V, C _L = 50 pF, R _L = 500 Ω, T _A = MIN to MAX†				UNIT
			SN54ALS30A		SN74ALS30A		
			MIN	MAX	MIN	MAX	
t _{PLH}	A, B, C, D, E, F, G, or H	Y	3	15	3	10	ns
t _{PHL}			3	15	3	12	

† For conditions shown as MIN or MAX, use the appropriate value specified under recommended operating conditions.

absolute maximum ratings over operating free-air temperature range (unless otherwise noted)‡

Supply voltage, V _{CC}	7 V
Input voltage, V _I	7 V
Operating free-air temperature range, T _A : SN54AS30	-55°C to 125°C
SN74AS30	0°C to 70°C
Storage temperature range	-65°C to 150°C

‡ Stresses beyond those listed under "absolute maximum ratings" may cause permanent damage to the device. These are stress ratings only, and functional operation of the device at these or any other conditions beyond those indicated under "recommended operating conditions" is not implied. Exposure to absolute-maximum-rated conditions for extended periods may affect device reliability.

recommended operating conditions

	SN54AS30			SN74AS30			UNIT
	MIN	NOM	MAX	MIN	NOM	MAX	
V _{CC} Supply voltage	4.5	5	5.5	4.5	5	5.5	V
V _{IH} High-level input voltage	2			2			V
V _{IL} Low-level input voltage			0.8			0.8	V
I _{OH} High-level output current			-2			-2	mA
I _{OL} Low-level output current			20			20	mA
T _A Operating free-air temperature	-55		125	0		70	°C

electrical characteristics over recommended operating free-air temperature range (unless otherwise noted)

PARAMETER	TEST CONDITIONS	SN54AS30			SN74AS30			UNIT
		MIN	TYP§	MAX	MIN	TYP§	MAX	
V _{IK}	V _{CC} = 4.5 V, I _I = -18 mA			-1.2			-1.2	V
V _{OH}	V _{CC} = 4.5 V to 5.5 V, I _{OH} = -2 mA	V _{CC} - 2			V _{CC} - 2			V
V _{OL}	V _{CC} = 4.5 V, I _{OL} = 20 mA		0.35	0.5		0.35	0.5	V
I _I	V _{CC} = 5.5 V, V _I = 7 V			0.1			0.1	mA
I _{IH}	V _{CC} = 5.5 V, V _I = 2.7 V			20			20	μA
I _{IL}	V _{CC} = 5.5 V, V _I = 0.4 V			-0.5			-0.5	mA
I _O ¶	V _{CC} = 5.5 V, V _O = 2.25 V	-30		-112	-30		-112	mA
I _{CCH}	V _{CC} = 5.5 V, V _I = 0		0.9	1.5		0.9	1.5	mA
I _{CCL}	V _{CC} = 5.5 V, V _I = 4.5 V		3	4.9		3	4.9	mA

§ All typical values are at V_{CC} = 5 V, T_A = 25°C.

¶ The output conditions have been chosen to produce a current that closely approximates one half of the true short-circuit output current, I_{OS}.



POST OFFICE BOX 655303 • DALLAS, TEXAS 75265

■ 8961723 0104386 810 ■

SN54ALS30A, SN54AS30, SN74ALS30A, SN74AS30 8-INPUT POSITIVE-NAND GATES

SDAS010B - MARCH 1984 - REVISED DECEMBER 1994

switching characteristics (see Figure 1)

PARAMETER	FROM (INPUT)	TO (OUTPUT)	$V_{CC} = 4.5 \text{ V to } 5.5 \text{ V},$ $C_L = 50 \text{ pF},$ $R_L = 500 \Omega,$ $T_A = \text{MIN to MAX}^\dagger$				UNIT
			SN54AS30		SN74AS30		
			MIN	MAX	MIN	MAX	
t_{PLH}	A, B, C, D, E, F, G, or H	Y	1	5.5	1	5	ns
t_{PHL}			1	5	1	4.5	

[†] For conditions shown as MIN or MAX, use the appropriate value specified under recommended operating conditions.



POST OFFICE BOX 655303 • DALLAS, TEXAS 75265

8961723 0104387 757

PARAMETER MEASUREMENT INFORMATION
SERIES 54ALS/74ALS AND 54AS/74AS DEVICES

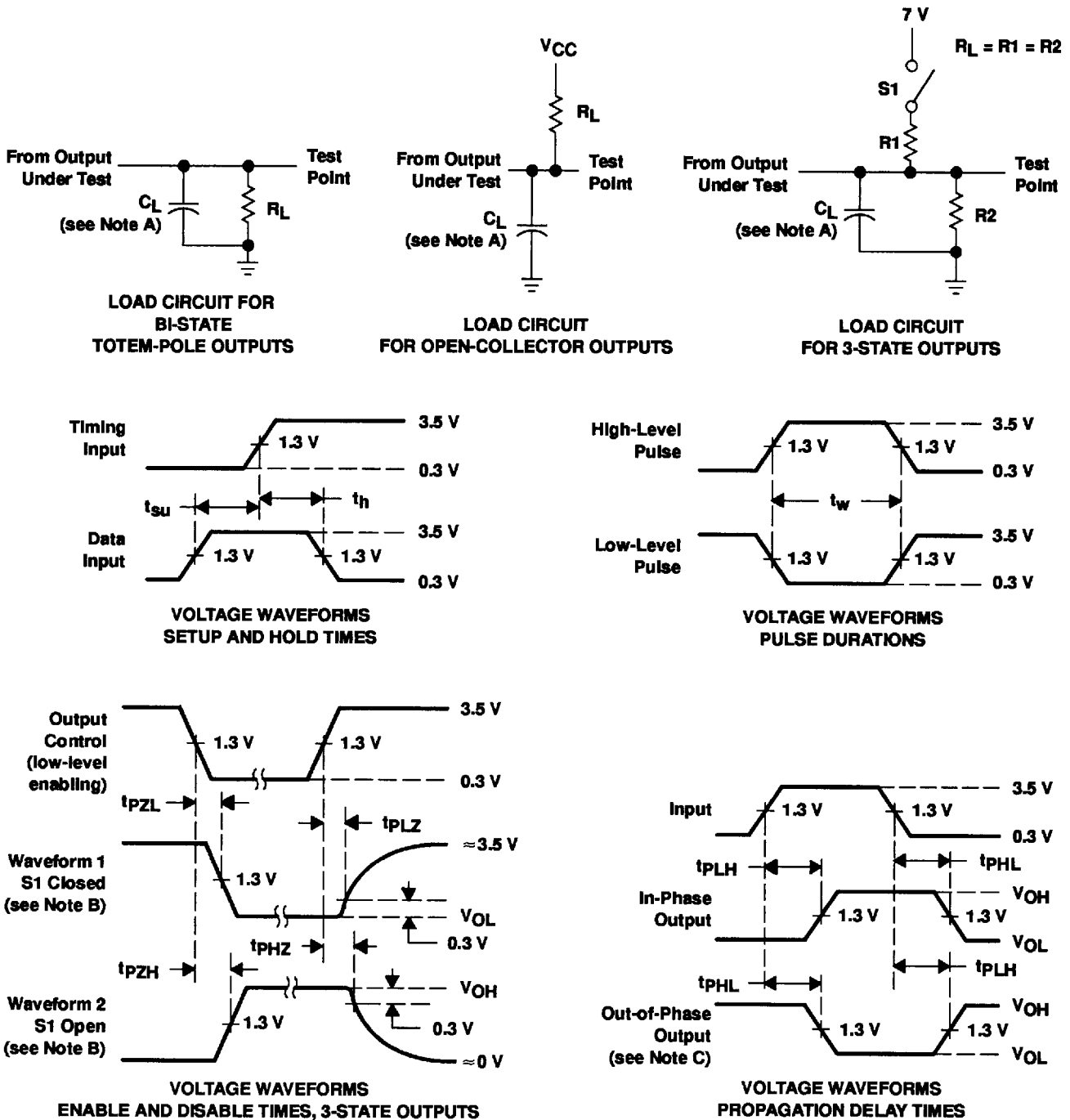

- NOTES: A. C_L includes probe and jig capacitance.
 B. Waveform 1 is for an output with internal conditions such that the output is low except when disabled by the output control. Waveform 2 is for an output with internal conditions such that the output is high except when disabled by the output control.
 C. When measuring propagation delay items of 3-state outputs, switch S1 is open.
 D. All input pulses have the following characteristics: $PRR \leq 1$ MHz, $t_r = t_f = 2$ ns, duty cycle = 50%.
 E. The outputs are measured one at a time with one transition per measurement.

Figure 1. Load Circuits and Voltage Waveforms