



U74AHC1G07

CMOS IC

BUFFER WITH OPEN-DRAIN OUTPUT

DESCRIPTION

The UTC **U74AHC1G07** is a CMOS device with open-drain output providing a buffer and it follows the Function $Y=A$.

FEATURES

- * Operation voltage range: 2 ~ 5.5V
- * Max t_{pd} of 7.5 ns at 5 V
- * Low static power consumption; $I_{CC}=1\mu A$ (Max.)
- * $\pm 8mA$ output drive at 5 V

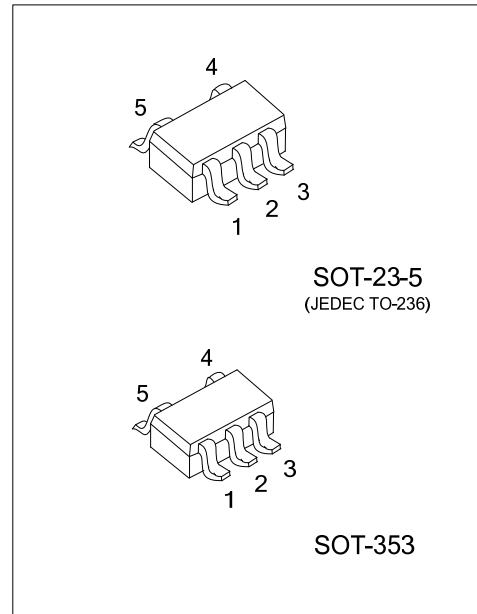

ORDERING INFORMATION

Ordering Number		Package	Packing
Lead Free	Halogen Free		
U74AHC1G07L-AE5-R	U74AHC1G07G-AE5-R	SOT-23-5	Tape Reel
U74AHC1G07L-AL5-R	U74AHC1G07G-AL5-R	SOT-353	Tape Reel

<p>U74AHC1G07G-AE5-R</p> <p>(1) Packing Type</p> <p>(2) Package Type</p> <p>(3) Green Package</p>	<p>(1) R: Tape Reel</p> <p>(2) AE5: SOT-23-5, AL5: SOT-353</p> <p>(3) G: Halogen Free and Lead Free, L: Lead Free</p>
---	---

MARKING

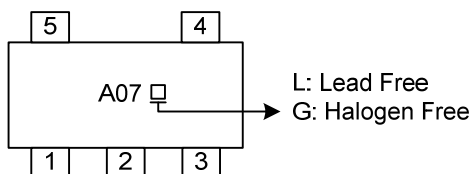

■ PIN CONFIGURATION

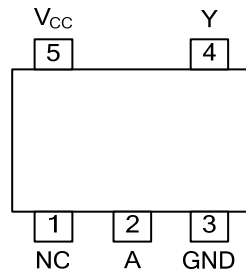

■ FUNCTION TABLE

INPUT A	OUTPUT Y
H	Z
L	L

Note: H: High Voltage Level
 L: Low Voltage Level
 Z: High-Impedance OFF-State

■ LOGIC DIAGRAM

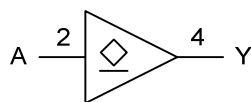

Logic symbol



IEC logic symbol

■

■ ABSOLUTE MAXIMUM RATING

PARAMETER	SYMBOL	CONDITIONS	RATINGS	UNIT
Supply Voltage	V_{CC}		-0.5 ~ +7.0	V
Input Voltage	V_{IN}		-0.5 ~ +7.0	V
Input Clamp Current	I_{IK}	$V_{IN} < -0.5V$	-20	mA
Output Clamp Current (Note 2)	I_{OK}	$V_{OUT} < -0.5V$	±20	mA
Continuous Output Current	I_{OUT}	$V_{OUT} > -0.5V$	±25	mA
Continuous V_{CC} or GND Current	I_{CC}		±75	mA
Power Dissipation	P_D		250	mW
Derate above $T_A > 87.5^\circ C$			4.0	mW/K
Operating Temperature	T_{OPR}		-40 ~ + 125	°C
Storage Temperature Range	T_{STG}		-65 ~ + 150	°C

Notes: 1. Absolute maximum ratings are those values beyond which the device could be permanently damaged. Absolute maximum ratings are stress ratings only and functional device operation is not implied.
 2. The input and output voltage ratings may be exceeded if the input and output current ratings are observed.

■ RECOMMENDED OPERATING CONDITIONS

PARAMETER	SYMBOL	CONDITIONS	MIN	TYP	MAX	UNIT
Supply Voltage	V_{CC}		2.0		5.5	V
Input Voltage	V_{IN}		0		5.5	V
Output Voltage	V_{OUT}		0		V_{CC}	V
Input Transition Rise or Fall Rate	$\Delta t/\Delta v$	$V_{CC}=3.3+0.3V$			100	ns/V
		$V_{CC}=5.0+0.5V$			20	ns/V

■ STATIC CHARACTERISTICS ($T_A=25^\circ C$, unless otherwise specified)

PARAMETER	SYMBOL	TEST CONDITIONS	MIN	TYP	MAX	UNIT	
High-Level Input Voltage	V_{IH}	$V_{CC}=2.0V$	1.5			V	
		$V_{CC}=3.0V$	2.1			V	
		$V_{CC}=5.5V$	3.85			V	
Low-Level Input Voltage	V_{IL}	$V_{CC}=2.0V$			0.5	V	
		$V_{CC}=3.0V$			0.9	V	
		$V_{CC}=5.5V$			1.65	V	
Low-Level Output Voltage	V_{OL}	$I_{OL}=50\mu A$	$V_{CC}=2.0V$			0.1	V
			$V_{CC}=3.0V$			0.1	V
			$V_{CC}=4.5V$			0.1	V
		$I_{OL}=4mA, V_{CC}=3.0V$			0.36	V	
		$I_{OL}=8mA, V_{CC}=4.5V$			0.36	V	
Input Leakage Current	$I_{I(LEAK)}$	$V_{IN}=V_{CC}$ or $GND, V_{CC}=5.5V$			0.1	μA	
3-state output OFF-state current	I_{OZ}	$V_{IN}=V_{IH}$ or $V_{IL}, V_{OUT}=V_{CC}$ or GND $V_{CC}=5.5V$			±0.25	μA	
Quiescent Supply Current	I_{CC}	$V_{IN}=V_{CC}$ or $GND, I_{OUT}=0A$ $V_{CC}=5.5V$			1.0	μA	
Input Capacitance	C_{IN}	$V_{IN}=V_{CC}$ or GND		1.5	10	pF	

■ DYNAMIC CHARACTERISTICS (Input: $t_R, t_F \leq 3\text{ns}$; $\text{PRR} \leq 1\text{MHz}$, $T_A = 25^\circ\text{C}$, unless otherwise specified)

PARAMETER	SYMBOL	TEST CONDITIONS	MIN	TYP	MAX	UNIT	
Propagation delay from input (A) to output (Y)	t_{PZL}	$V_{CC} = 3.3 \pm 0.3 \text{ V}$	$C_L = 15 \text{ pF}$		3.5	5.6	ns
			$C_L = 50 \text{ pF}$		5.0	8.0	ns
	t_{PLZ}		$C_L = 15 \text{ pF}$		5.8	7.9	ns
			$C_L = 50 \text{ pF}$		8.3	11.5	ns
	t_{PZL}	$V_{CC} = 5 \pm 0.5 \text{ V}$	$C_L = 15 \text{ pF}$		2.5	3.9	ns
			$C_L = 50 \text{ pF}$		3.6	5.5	ns
	t_{PLZ}		$C_L = 15 \text{ pF}$		4.2	5.1	ns
			$C_L = 50 \text{ pF}$		6.0	7.5	ns

■ TEST CIRCUIT AND WAVEFORMS

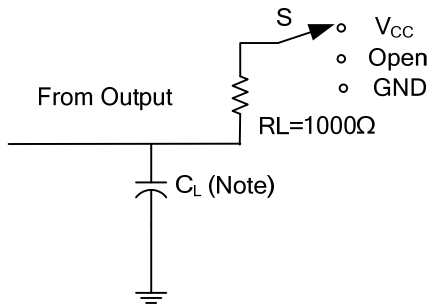

TEST	S
t_{PLH}/t_{PHL}	Open
t_{PHZ}/t_{PZH}	GND
t_{PLZ}/t_{PZL}	V_{CC}

TEST CIRCUIT

Note: C_L includes probe and jig capacitance.

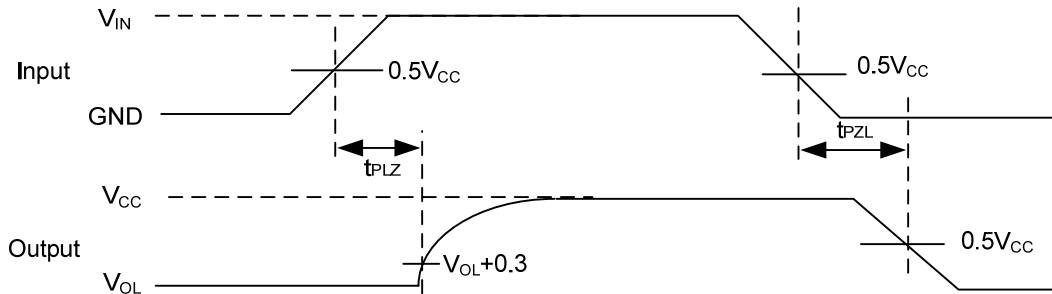

PROPAGATION DELAY TIMES

UTC assumes no responsibility for equipment failures that result from using products at values that exceed, even momentarily, rated values (such as maximum ratings, operating condition ranges, or other parameters) listed in products specifications of any and all UTC products described or contained herein. UTC products are not designed for use in life support appliances, devices or systems where malfunction of these products can be reasonably expected to result in personal injury. Reproduction in whole or in part is prohibited without the prior written consent of the copyright owner. UTC reserves the right to make changes to information published in this document, including without limitation specifications and product descriptions, at any time and without notice. This document supersedes and replaces all information supplied prior to the publication hereof.