



## 54F/74F563 Octal D-Type Latch with TRI-STATE® Outputs

### General Description

The 'F563 is a high-speed octal latch with buffered common Latch Enable (LE) and buffered common Output Enable ( $\overline{OE}$ ) inputs.

This device is functionally identical to the 'F573, but has inverted outputs.

### Features

- Inputs and outputs on opposite sides of package allowing easy interface with microprocessors
- Useful as input or output port for microprocessors
- Functionally identical to 'F573

**Ordering Code:** See Section 5

### Logic Symbols

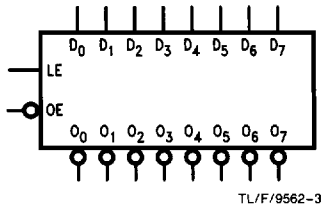

TL/F/9562-3

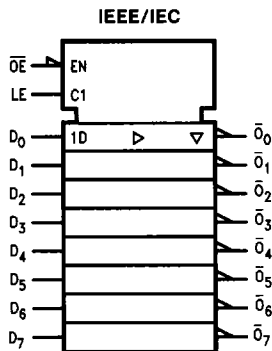

TL/F/9562-5

### Connection Diagrams

Pin Assignment for  
DIP, SOIC and Flatpak

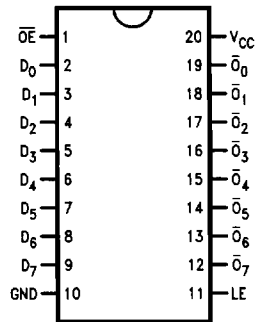

TL/F/9562-1

Pin Assignment  
for LCC and PCC

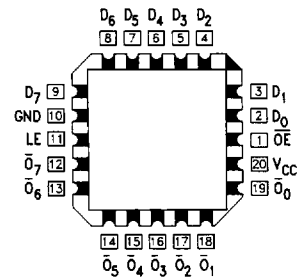

TL/F/9562-2

**Unit Loading/Fan Out:** See Section 2 for U.L. definitions

Pin Names	Description	54F/74F	
		U.L. HIGH/LOW	Input $I_{IH}/I_{IL}$ Output $I_{OH}/I_{OL}$
D <sub>0</sub> -D <sub>7</sub>	Data Inputs	1.0/1.0	20 $\mu$ A/ -0.6 mA
LE	Latch Enable Input (Active HIGH)	1.0/1.0	20 $\mu$ A/ -0.6 mA
$\overline{OE}$	TRI-STATE Output Enable Input (Active LOW)	1.0/1.0	20 $\mu$ A/ -0.6 mA
$\overline{O_0}$ - $\overline{O_7}$	TRI-STATE Latch Outputs	150/40 (33.3)	-3 mA/24 mA (20 mA)

## Functional Description

The 'F563 contains eight D-type latches with TRI-STATE output buffers. When the Latch Enable (LE) input is HIGH, data on the  $D_n$  inputs enters the latches. In this condition the latches are transparent, i.e., a latch output will change state each time its D input changes. When LE is LOW the latches store the information that was present on the D inputs a setup time preceding the HIGH-to-LOW transition of LE. The TRI-STATE buffers are controlled by the Output Enable ( $\overline{OE}$ ) input. When  $\overline{OE}$  is LOW, the buffers are in the bi-state mode. When  $\overline{OE}$  is HIGH the buffers are in the high impedance mode but this does not interfere with entering new data into the latches.

Function Table

Inputs			Internal	Output	Function
$\overline{OE}$	LE	D	Q	O	
H	X	X	X	Z	High Z
H	H	L	H	Z	High Z
H	H	H	L	Z	High Z
H	L	X	NC	Z	Latched
L	H	L	H	H	Transparent
L	H	H	L	L	Transparent
L	L	X	NC	NC	Latched

H = HIGH Voltage Level  
 L = LOW Voltage Level  
 X = Immaterial  
 Z = High Impedance  
 NC = No Change

## Logic Diagram

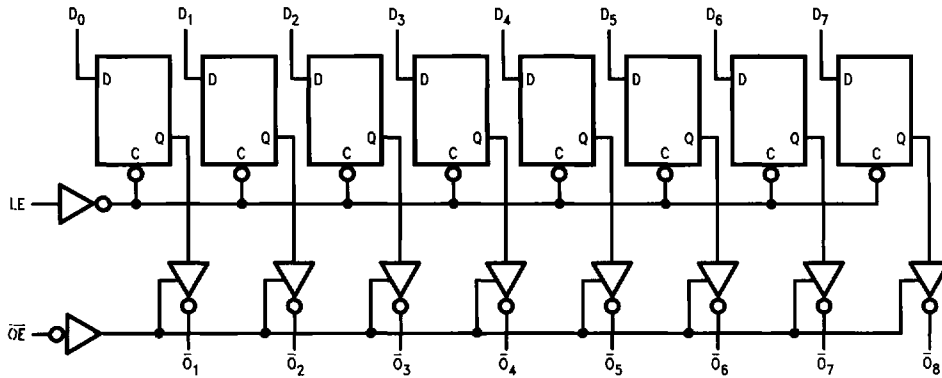

TL/F/9562-4

Please note that this diagram is provided only for the understanding of logic operations and should not be used to estimate propagation delays.

## Absolute Maximum Ratings (Note 1)

If Military/Aerospace specified devices are required, contact the National Semiconductor Sales Office/Distributors for availability and specifications.

Storage Temperature	-65°C to +150°C
Ambient Temperature under Bias	-55°C to +125°C
Junction Temperature under Bias	-55°C to +175°C
V <sub>CC</sub> Pin Potential to Ground Pin	-0.5V to +7.0V
Input Voltage (Note 2)	-0.5V to +7.0V
Input Current (Note 2)	-30 mA to +5.0 mA
Voltage Applied to Output in HIGH State (with V <sub>CC</sub> = 0V)	
Standard Output	-0.5V to V <sub>CC</sub>
TRI-STATE Output	-0.5V to +5.5V

Current Applied to Output in LOW State (Max) twice the rated I<sub>OL</sub> (mA)

**Note 1:** Absolute maximum ratings are values beyond which the device may be damaged or have its useful life impaired. Functional operation under these conditions is not implied.

**Note 2:** Either voltage limit or current limit is sufficient to protect inputs.

## Recommended Operating Conditions

Free Air Ambient Temperature

Military	-55°C to +125°C
Commercial	0°C to +70°C

Supply Voltage

Military	+4.5V to +5.5V
Commercial	+4.5V to +5.5V

## DC Electrical Characteristics

Symbol	Parameter	54F/74F			Units	V <sub>CC</sub>	Conditions
		Min	Typ	Max			
V <sub>IH</sub>	Input HIGH Voltage	2.0			V		Recognized as a HIGH Signal
V <sub>IL</sub>	Input LOW Voltage			0.8	V		Recognized as a LOW Signal
V <sub>CD</sub>	Input Clamp Diode Voltage			-1.2	V	Min	I <sub>IN</sub> = -18 mA
V <sub>OH</sub>	Output HIGH Voltage	54F 10% V <sub>CC</sub> 54F 10% V <sub>CC</sub> 74F 10% V <sub>CC</sub> 74F 10% V <sub>CC</sub> 74F 5% V <sub>CC</sub> 74F 5% V <sub>CC</sub>	2.5 2.4 2.5 2.4 2.7 2.7		V	Min	I <sub>OH</sub> = -1 mA I <sub>OH</sub> = -3 mA I <sub>OH</sub> = -1 mA I <sub>OH</sub> = -3 mA I <sub>OH</sub> = -1 mA I <sub>OH</sub> = -3 mA
V <sub>OL</sub>	Output LOW Voltage	54F 10% V <sub>CC</sub> 74F 10% V <sub>CC</sub>		0.5 0.5	V	Min	I <sub>OL</sub> = 20 mA I <sub>OL</sub> = 24 mA
I <sub>IH</sub>	Input HIGH Current			20	μA	Max	V <sub>IN</sub> = 2.7V
I <sub>BVI</sub>	Input HIGH Current Breakdown Test			100	μA	Max	V <sub>IN</sub> = 7.0V
I <sub>IL</sub>	Input LOW Current			-0.6	mA	Max	V <sub>IN</sub> = 0.5V
I <sub>OZH</sub>	Output Leakage Current			50	μA	Max	V <sub>OUT</sub> = 2.7V
I <sub>OZL</sub>	Output Leakage Current			-50	μA	Max	V <sub>OUT</sub> = 0.5V
I <sub>OS</sub>	Output Short-Circuit Current			-60	mA	Max	V <sub>OUT</sub> = 0V
I <sub>CEX</sub>	Output HIGH Leakage Current			250	μA	Max	V <sub>OUT</sub> = V <sub>CC</sub>
I <sub>ZZ</sub>	Bus Drainage Test			500	μA	0.0V	V <sub>OUT</sub> = V <sub>CC</sub>
I <sub>CCL</sub>	Power Supply Current		40	61	mA	Max	V <sub>O</sub> = LOW
I <sub>CCZ</sub>	Power Supply Current		40	61	mA	Max	V <sub>O</sub> = HIGH Z

**AC Electrical Characteristics:** See Section 2 for Waveforms and Load Configurations

Symbol	Parameter	74F			54F		74F		Units	Fig No
		$T_A = +25^\circ\text{C}$ $V_{CC} = +5.0\text{V}$ $C_L = 50\text{ pF}$			$T_A, V_{CC} = \text{Mil}$ $C_L = 50\text{ pF}$		$T_A, V_{CC} = \text{Com}$ $C_L = 50\text{ pF}$			
		Min	Typ	Max	Min	Max	Min	Max		
$t_{PLH}$ $t_{PHL}$	Propagation Delay $D_n$ to $\bar{O}_n$	3.5 2.5		8.5 6.5	3.0 2.0	10.5 7.5	3.0 2.0	9.5 7.0	ns	2-3
$t_{PLH}$ $t_{PHL}$	Propagation Delay LE to $\bar{O}_n$	4.5 3.0		9.5 7.0	4.0 2.5	11.0 7.5	4.0 2.5	10.5 7.0	ns	2-3
$t_{PZH}$ $t_{PZL}$	Output Enable Time	2.0 3.0		7.5 8.5	2.0 2.5	9.5 10.0	2.0 1.5	9.0 9.5	ns	2-5
$t_{PHZ}$ $t_{PLZ}$	Output Disable Time	1.5 1.5		5.5 5.5	1.5 1.5	7.0 5.5	1.5 1.5	6.5 5.5		

**AC Operating Requirements:** See Section 2 for Waveforms

Symbol	Parameter	74F		54F		74F		Units	Fig No
		$T_A = +25^\circ\text{C}$ $V_{CC} = +5.0\text{V}$		$T_A, V_{CC} = \text{Mil}$		$T_A, V_{CC} = \text{Com}$			
		Min	Max	Min	Max	Min	Max		
$t_s(H)$ $t_s(L)$	Setup Time, HIGH or LOW $D_n$ to LE	2.0 2.0		2.0 2.0	2.0 2.0	2.0 2.0	2.0 2.0	ns	2-6
$t_h(H)$ $t_h(L)$	Hold Time, HIGH or LOW $D_n$ to LE	3.0 3.0		3.0 3.0	3.0 3.0	3.0 3.0	3.0 3.0	ns	2-6
$t_w(H)$	LE Pulse Width, HIGH	4.0		4.0	4.0	4.0	4.0	ns	2-4