

DM74LS33 Quad 2-Input NOR Buffer with Open-Collector Outputs

General Description

This device contains four independent gates each of which perform the logic NOR function. Outputs are open-collector.

Connection Diagram

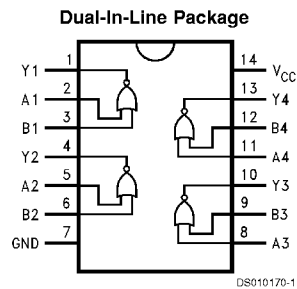

Order Number DM54LS33J, DM54LS33W DM74LS33M or DM74LS33N
See Package Number J14A, M14A, N14A or W14B

Function Table

$$Y = \overline{A + B}$$

Inputs		Output
A	B	Y
L	L	H
L	H	L
H	L	L
H	H	L

H = High Logic Level
L = Low Logic Level

Absolute Maximum Ratings (Note 1)

Supply Voltage	7V	Operating Free Air Temperature Range	54LS	-55°C to +125°C
Input Voltage	7V		DM74LS	0°C to +70°C
Output Voltage	7V	Storage Temperature Range		-65°C to +150°C

Recommended Operating Conditions

Symbol	Parameter	DM54LS33			DM74LS33			Units
		Min	Nom	Max	Min	Nom	Max	
V _{CC}	Supply Voltage	4.5	5	5.5	4.75	5	5.25	V
V _{IH}	High Level Input Voltage	2			2			V
V _{IL}	Low Level Input Voltage			0.7			0.8	V
V _{OH}	High Level Output Voltage			5.5			5.5	V
I _{OL}	Low Level Output Current			12			24	mA
T _A	Free Air Operating Temperature	-55		125	0		70	°C

Note 1: The "Absolute Maximum Ratings" are those values beyond which the safety of the device cannot be guaranteed. The device should not be operated at these limits. The parametric values defined in the "Electrical Characteristics" table are not guaranteed at the absolute maximum ratings. The "Recommended Operating Conditions" table will define the conditions for actual device operation.

Electrical Characteristics

over recommended operating free air temperature range (unless otherwise noted)

Symbol	Parameter	Conditions	Min	Typ (Note 2)	Max	Units
V _I	Input Clamp Voltage	V _{CC} = Min, I _I = -18 mA			-1.5	V
I _{CEX}	High Level Output Current	V _{CC} = Min, V _O = 5.5V, V _{IL} = Max			100	μA
V _{OL}	Low Level Output Voltage	V _{CC} = Min, I _{OL} = Max,	DM54		0.4	V
		V _{IH} = Min	DM74		0.5	
		I _{OL} = 12 mA, V _{CC} = Min	DM74		0.4	
I _I	Input Current @ Max Input Voltage	V _{CC} = Max, V _I = 7V			0.1	mA
I _{IH}	High Level Input Current	V _{CC} = Max, V _I = 2.7V			20	μA
I _{IL}	Low Level Input Current	V _{CC} = Max, V _I = 0.4V			-0.4	mA
I _{CCH}	Supply Current with Outputs High	V _{CC} = Max V _{IN} = GND			3.6	mA
I _{CCL}	Supply Current with Outputs Low	V _{CC} = Max V _{IN} = Open			13.8	mA

Note 2: All typicals are at V_{CC} = 5V, T_A = 25°C.

Switching Characteristics

at V_{CC} = 5V and T_A = 25°C

Symbol	Parameter	R _L = 2 kΩ C _L = 15 pF		Units
		Min	Max	
t _{PLH}	Propagation Delay Time Low to High Level Output		22	ns
t _{PHL}	Propagation Delay Time High to Low Level Output		22	ns

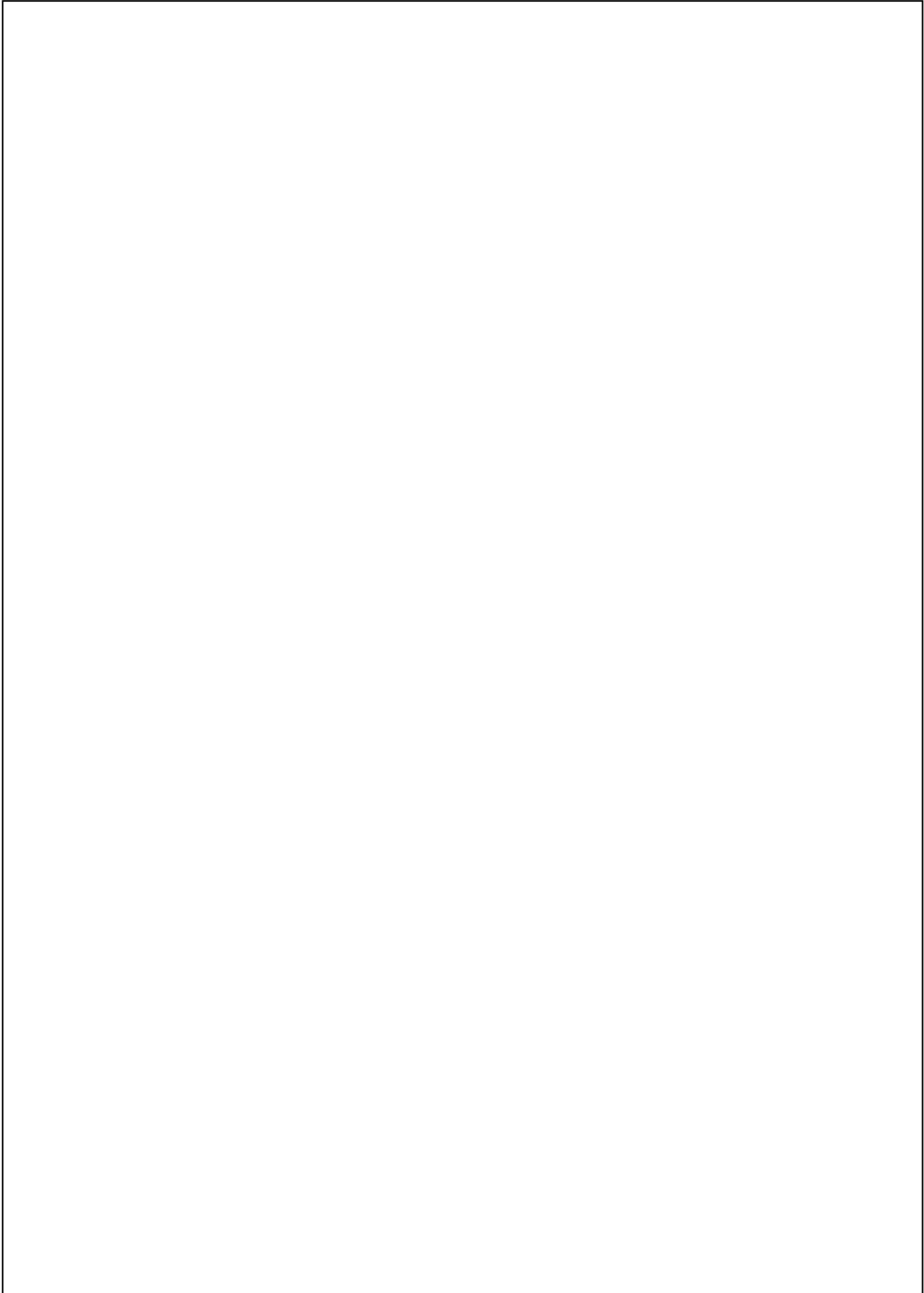

Physical Dimensions inches (millimeters) unless otherwise noted

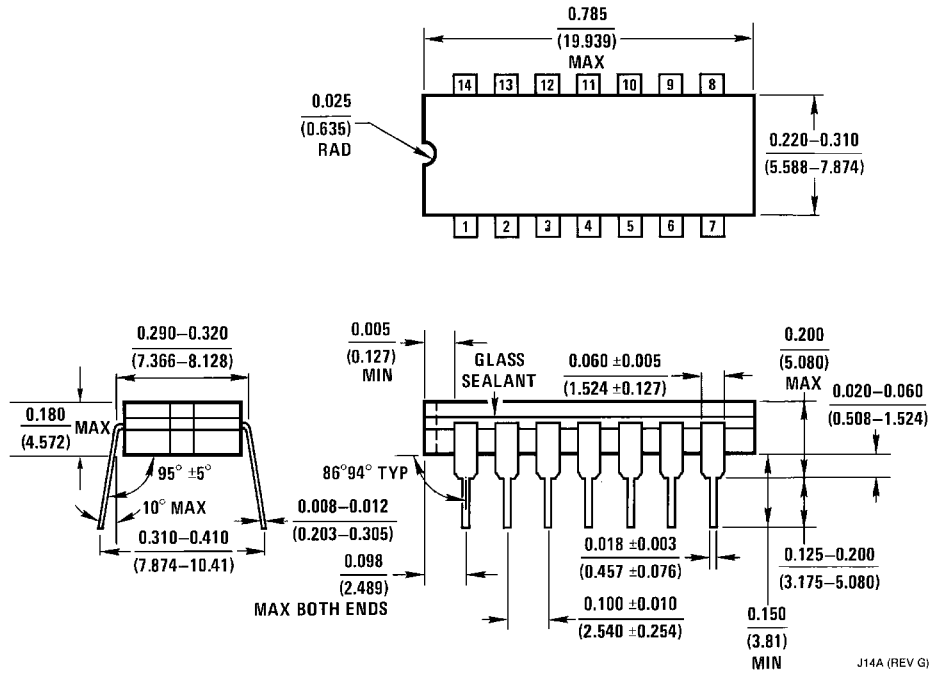

14-Lead Ceramic Dual-In-Line Package (J)
Order Number DM54LS33J
Package Number J14A

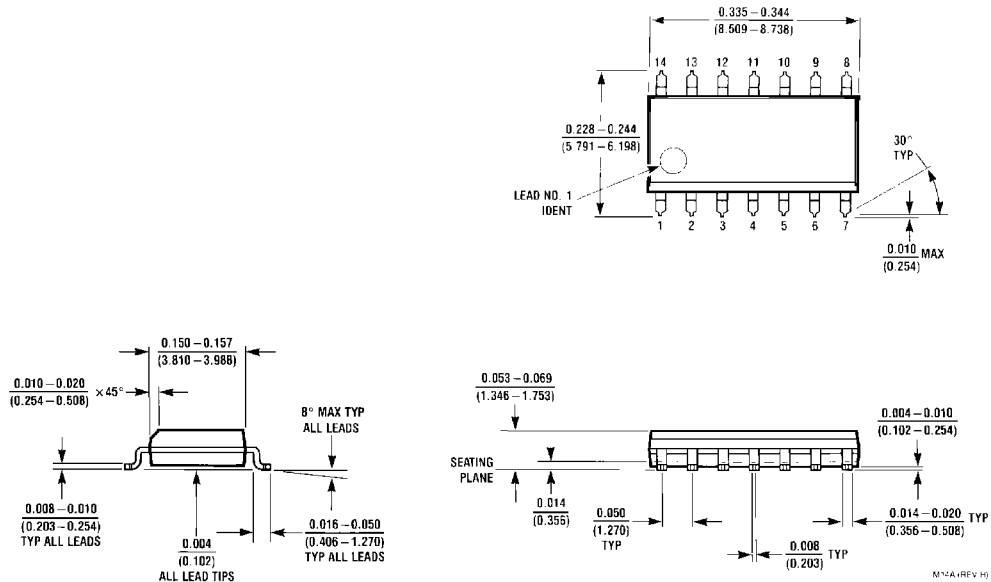

14-Lead Small Outline Molded Package (M)
Order Number DM74LS33M
Package Number M14A

Physical Dimensions inches (millimeters) unless otherwise noted (Continued)

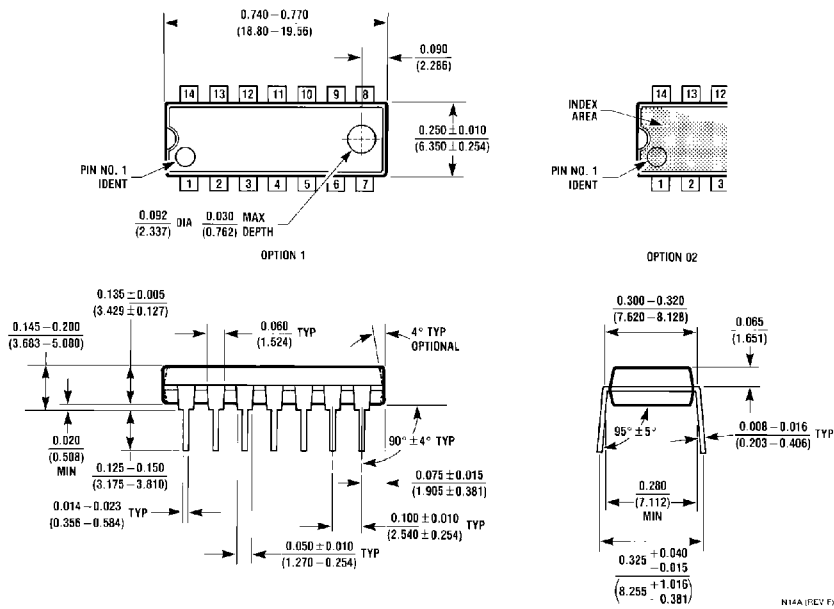

14-Lead Molded Dual-In-Line Package (N)
Order Number DM74LS33N
Package Number N14A

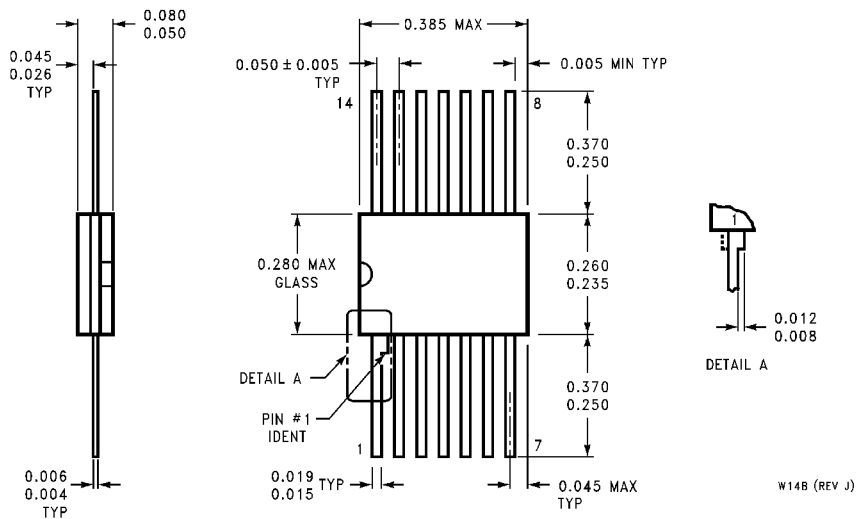

14-Lead Ceramic Flat Package (W)
Order Number DM54LS33W
Package Number W14B

LIFE SUPPORT POLICY

FAIRCHILD'S PRODUCTS ARE NOT AUTHORIZED FOR USE AS CRITICAL COMPONENTS IN LIFE SUPPORT DEVICES OR SYSTEMS WITHOUT THE EXPRESS WRITTEN APPROVAL OF THE PRESIDENT OF FAIRCHILD SEMICONDUCTOR CORPORATION. As used herein:

1. Life support devices or systems are devices or systems which, (a) are intended for surgical implant into the body, or (b) support or sustain life, and (c) whose failure to perform when properly used in accordance with instructions for use provided in the labeling, can be reasonably expected to result in a significant injury to the user.
2. A critical component in any component of a life support device or system whose failure to perform can be reasonably expected to cause the failure of the life support device or system, or to affect its safety or effectiveness.

Fairchild Semiconductor Corporation
Americas
Customer Response Center
Tel: 1-888-522-5372

www.fairchildsemi.com

Fairchild Semiconductor Europe
Fax: +49 (0) 1 80-530 85 86
Email: europa.support@nsc.com
Deutsch Tel: +49 (0) 8 141-35-0
English Tel: +44 (0) 1 793-85-68-56
Italy Tel: +39 (0) 2 57 5631

Fairchild Semiconductor Hong Kong Ltd.
13th Floor, Straight Block,
Ocean Centre, 5 Canton Rd.
Tsimshatsui, Kowloon
Hong Kong
Tel: +852 2737-7200
Fax: +852 2314-0061

National Semiconductor Japan Ltd.
Tel: 81-3-5620-6175
Fax: 81-3-5620-6179