



Integrated Device Technology, Inc.

# FAST CMOS 1-OF-8 DECODER WITH ENABLE

**IDT54/74FCT138**  
**IDT54/74FCT138A**  
**IDT54/74FCT138C**

## FEATURES:

- IDT54/74FCT138 equivalent to FAST™ speed
- **IDT54/74FCT138A 35% faster than FAST**
- **IDT54/74FCT138C 40% faster than FAST**
- Equivalent to FAST speeds output drive over full temperature and voltage supply extremes
- $I_{OL} = 48\text{mA}$  (commercial) and  $32\text{mA}$  (military)
- CMOS power levels (1mW typ. static)
- TTL input and output level compatible
- CMOS output level compatible
- Substantially lower input current levels than FAST ( $5\mu\text{A}$  max.)
- JEDEC standard pinout for DIP and LCC
- Product available in Radiation Tolerant and Radiation Enhanced versions
- Military product compliant to MIL-STD-883, Class B
- Standard Military Drawing # 5962-87654 is listed on this function. Refer to section 2.

## DESCRIPTION:

The IDT54/74FCT138/A/C are 1-of-8 decoders built using an advanced dual metal CMOS technology. The IDT54/74FCT138/A/C accept three binary weighted inputs ( $A_0$ ,  $A_1$ ,  $A_2$ ) and, when enabled, provide eight mutually exclusive active LOW outputs ( $\bar{O}_0 - \bar{O}_7$ ). The IDT54/74FCT138/A/C feature three enable inputs, two active LOW ( $\bar{E}_1$ ,  $\bar{E}_2$ ) and one active HIGH ( $E_3$ ). All outputs will be HIGH unless  $\bar{E}_1$  and  $\bar{E}_2$  are LOW and  $E_3$  is HIGH. This multiple enable function allows easy parallel expansion of the device to a 1-of-32 (5 lines to 32 lines) decoder with just four IDT54/74FCT138/A/C devices and one inverter.

## FUNCTIONAL BLOCK DIAGRAM

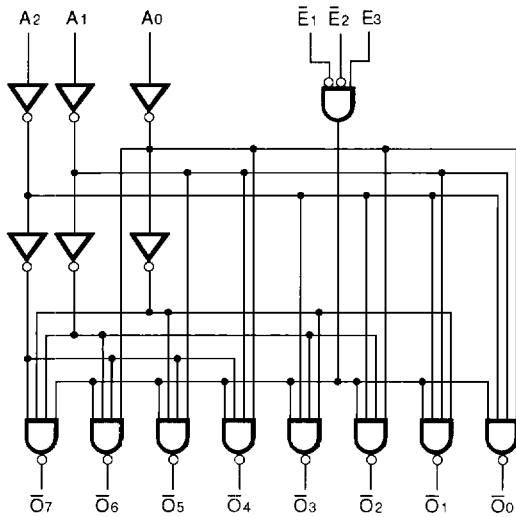

2581 drw 02

## PIN CONFIGURATIONS

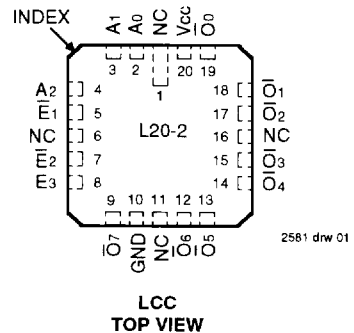
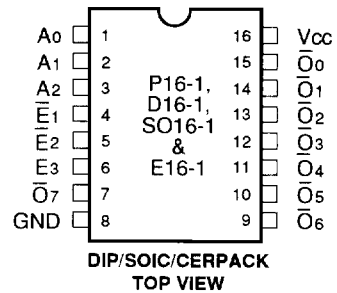

2581 drw 01

The IDT logic is a registered trademark of Integrated Device Technology, Inc.  
FAST is a trademark of National Semiconductor Co.

**MILITARY AND COMMERCIAL TEMPERATURE RANGES**

**MAY 1992**

## PIN DESCRIPTION

Pin Names	Description
A0–A2	Address Inputs
$\bar{E}_1, \bar{E}_2$	Enable Inputs (Active LOW)
E3	Enable Input (Active HIGH)
$\bar{O}_0$ – $\bar{O}_7$	Outputs (Active LOW)

2581 tbi 05

## FUNCTION TABLE

Inputs						Outputs							
$\bar{E}_1$	$\bar{E}_2$	E3	A0	A1	A2	$\bar{O}_0$	$\bar{O}_1$	$\bar{O}_2$	$\bar{O}_3$	$\bar{O}_4$	$\bar{O}_5$	$\bar{O}_6$	$\bar{O}_7$
H	X	X	X	X	X	H	H	H	H	H	H	H	H
X	H	X	X	X	X	H	H	H	H	H	H	H	H
X	X	L	X	X	X	H	H	H	H	H	H	H	H
L	L	H	L	L	L	L	H	H	H	H	H	H	H
L	L	H	H	L	L	L	L	H	H	H	H	H	H
L	L	H	L	H	L	L	H	L	H	H	H	H	H
L	L	H	H	H	L	L	H	H	L	H	H	H	H
L	L	H	L	L	H	H	H	H	H	L	H	H	H
L	L	H	L	H	H	H	H	H	H	H	L	H	H
L	L	H	H	H	H	H	H	H	H	H	H	L	L

2581 tbi 06

## ABSOLUTE MAXIMUM RATINGS<sup>(1)</sup>

Symbol	Rating	Commercial	Military	Unit
V <sub>TERM</sub> <sup>(2)</sup>	Terminal Voltage with Respect to GND	–0.5 to +7.0	–0.5 to +7.0	V
V <sub>TERM</sub> <sup>(3)</sup>	Terminal Voltage with Respect to GND	–0.5 to V <sub>CC</sub>	–0.5 to V <sub>CC</sub>	V
T <sub>A</sub>	Operating Temperature	0 to +70	–55 to +125	°C
T <sub>BIAS</sub>	Temperature Under Bias	–55 to +125	–65 to +135	°C
T <sub>STG</sub>	Storage Temperature	–55 to +125	–65 to +150	°C
P <sub>T</sub>	Power Dissipation	0.5	0.5	W
I <sub>OUT</sub>	DC Output Current	120	120	mA

### NOTES:

2581 tbi 01

- Stresses greater than those listed under ABSOLUTE MAXIMUM RATINGS may cause permanent damage to the device. This is a stress rating only and functional operation of the device at these or any other conditions above those indicated in the operational sections of this specification is not implied. Exposure to absolute maximum rating conditions for extended periods may affect reliability. No terminal voltage may exceed V<sub>CC</sub> by +0.5V unless otherwise noted.
- Inputs and V<sub>CC</sub> terminals only.
- Outputs and I/O terminals only.

## CAPACITANCE (T<sub>A</sub> = +25°C, f = 1.0MHz)

Symbol	Parameter <sup>(1)</sup>	Conditions	Typ.	Max.	Unit
C <sub>IN</sub>	Input Capacitance	V <sub>IN</sub> = 0V	6	10	pF
C <sub>OUT</sub>	Output Capacitance	V <sub>OUT</sub> = 0V	8	12	pF

### NOTE:

2581 tbi 02

- This parameter is guaranteed characterization data and not tested.

## DC ELECTRICAL CHARACTERISTICS OVER OPERATING RANGE

Following Conditions Apply Unless Otherwise Specified:  $V_{LC} = 0.2V$ ;  $V_{HC} = V_{CC} - 0.2V$   
Commercial:  $T_A = 0^\circ C$  to  $+70^\circ C$ ,  $V_{CC} = 5.0V \pm 5\%$ ; Military:  $T_A = -55^\circ C$  to  $+125^\circ C$ ,  $V_{CC} = 5.0V \pm 10\%$

Symbol	Parameter	Test Conditions <sup>(1)</sup>	Min.	Typ. <sup>(2)</sup>	Max.	Unit	
$V_{IH}$	Input HIGH Level	Guaranteed Logic HIGH Level	2.0	—	—	V	
$V_{IL}$	Input LOW Level	Guaranteed Logic LOW Level	—	—	0.8	V	
$I_{IH}$	Input HIGH Current	$V_{CC} = \text{Max.}$ $V_I = V_{CC}$ $V_I = 2.7V$ $V_I = 0.5V$ $V_I = GND$	—	—	5	$\mu A$	
$I_{IL}$	Input LOW Current		—	—	$5^{(4)}$		
			—	—	$-5^{(4)}$		
$V_{IK}$	Clamp Diode Voltage	$V_{CC} = \text{Min.}$ , $I_N = -18mA$	—	-0.7	-1.2	V	
$I_{OS}$	Short Circuit Current	$V_{CC} = \text{Max.}^{(3)}$ , $V_O = GND$	-60	-120	—	mA	
$V_{OH}$	Output HIGH Voltage	$V_{CC} = 3V$ , $V_{IN} = V_{LC}$ or $V_{HC}$ , $I_{OH} = -32\mu A$	$V_{HC}$	$V_{CC}$	—	V	
		$V_{CC} = \text{Min.}$ $V_{IN} = V_{IH}$ or $V_{IL}$	$I_{OH} = -300\mu A$	$V_{HC}$	$V_{CC}$		—
			$I_{OH} = -12mA \text{ MIL.}$	2.4	4.3		—
		$I_{OH} = -15mA \text{ COM'L.}$	2.4	4.3	—		
$V_{OL}$	Output LOW Voltage	$V_{CC} = 3V$ , $V_{IN} = V_{LC}$ or $V_{HC}$ , $I_{OL} = 300\mu A$	—	GND	$V_{LC}$	V	
		$V_{CC} = \text{Min.}$ $V_{IN} = V_{IH}$ or $V_{IL}$	$I_{OL} = 300\mu A$	—	GND		$V_{LC}^{(4)}$
			$I_{OL} = 32mA \text{ MIL.}$	—	0.3		0.5
			$I_{OL} = 48mA \text{ COM'L.}$	—	0.3		0.5

### NOTES:

- For conditions shown as Max. or Min., use appropriate value specified under Electrical Characteristics for the applicable device type.
- Typical values are at  $V_{CC} = 5.0V$ ,  $+25^\circ C$  ambient and maximum loading.
- Not more than one output should be shorted at one time. Duration of the short circuit test should not exceed one second.
- This parameter is guaranteed but not tested.

2581 tbi 03

## POWER SUPPLY CHARACTERISTICS

$V_{LC} = 0.2V$ ;  $V_{HC} = V_{CC} - 0.2V$

Symbol	Parameter	Test Conditions <sup>(1)</sup>	Min.	Typ. <sup>(2)</sup>	Max.	Unit
$I_{CC}$	Quiescent Power Supply Current	$V_{CC} = \text{Max.}$ $V_{IN} \geq V_{HC}$ ; $V_{IN} \leq V_{LC}$	—	0.2	1.5	mA
$\Delta I_{CC}$	Quiescent Power Supply Current TTL Inputs HIGH	$V_{CC} = \text{Max.}$ $V_{IN} = 3.4V^{(3)}$	—	0.5	2.0	mA
$I_{CCD}$	Dynamic Power Supply Current <sup>(4)</sup>	$V_{CC} = \text{Max.}$ Outputs Open One Output Toggling 50% Duty Cycle	$V_{IN} \geq V_{HC}$ $V_{IN} \leq V_{LC}$	0.15	0.3	mA/MHz
$I_C$	Total Power Supply Current <sup>(5)</sup>	$V_{CC} = \text{Max.}$ Outputs Open Toggle E1, E2 or E3 50% Duty Cycle $f_O = 10MHz$ One Output Toggling	$V_{IN} \geq V_{HC}$ $V_{IN} \leq V_{LC}$ (FCT)	1.7	4.5	mA
			$V_{IN} = 3.4V$ $V_{IN} = GND$	2.0	5.5	

### NOTES:

- For conditions shown as Max. or Min., use appropriate value specified under Electrical Characteristics for the applicable device type.
- Typical values are at  $V_{CC} = 5.0V$ ,  $+25^\circ C$  ambient.
- Per TTL driven input ( $V_{IN} = 3.4V$ ): all other inputs at  $V_{CC}$  or GND.
- This parameter is not directly testable, but is derived for use in Total Power Supply calculations.
- $I_C = I_{QUIESCENT} + I_{INPUTS} + I_{DYNAMIC}$   
 $I_C = I_{CC} + \Delta I_{CC} DH + I_{CCD} (f_{CP}/2 + f_{NO})$   
 $I_{CC} = \text{Quiescent Current}$   
 $\Delta I_{CC} = \text{Power Supply Current for a TTL High Input } (V_{IN} = 3.4V)$   
 $DH = \text{Duty Cycle for TTL Inputs High}$   
 $NT = \text{Number of TTL Inputs at DH}$   
 $I_{CCD} = \text{Dynamic Current Caused by an Output Transition Pair (HLH or LHL)}$   
 $f_{CP} = \text{Clock Frequency for Register Devices (Zero for Non-Register Devices)}$   
 $f_O = \text{Output Frequency}$   
 $NO = \text{Number of Outputs at } f_O$   
 All currents are in milliamperes and all frequencies are in megahertz.

2581 tbi 04

**SWITCHING CHARACTERISTICS OVER OPERATING RANGE**

Symbol	Parameter	Condition <sup>(1)</sup>	IDT54/74FCT138				IDT54/74FCT138A				IDT54/74FCT138C				Unit
			Com'l.		Mil.		Com'l.		Mil.		Com'l.		Mil.		
			Min. <sup>(2)</sup>	Max.	Min. <sup>(2)</sup>	Max.	Min. <sup>(2)</sup>	Max.	Min. <sup>(2)</sup>	Max.	Min. <sup>(2)</sup>	Max.	Min. <sup>(2)</sup>	Max.	
tPLH tPHL	Propagation Delay A <sub>n</sub> to $\bar{O}_n$	C <sub>L</sub> = 50pF R <sub>L</sub> = 500Ω	1.5	9.0	1.5	12.0	1.5	5.8	1.5	7.8	1.5	5.1	1.5	6.0	ns
tPLH tPHL	Propagation Delay E <sub>1</sub> or E <sub>2</sub> to $\bar{O}_n$		1.5	9.0	1.5	12.5	1.5	5.9	1.5	8.0	1.5	5.2	1.5	6.1	ns
tPLH tPHL	Propagation Delay E <sub>3</sub> to $\bar{O}_n$		1.5	9.0	1.5	12.5	1.5	5.9	1.5	8.0	1.5	5.2	1.5	6.1	ns

**NOTES:**

1. See test circuit and waveforms.
2. Minimum limits are guaranteed but not tested on Propagation Delays.

2581 tbl07

## TEST CIRCUITS AND WAVEFORMS

### TEST CIRCUITS FOR ALL OUTPUTS

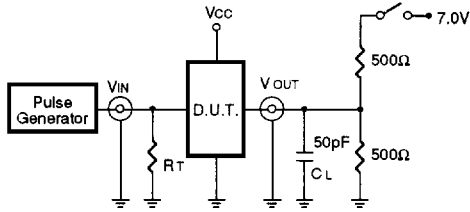

### SWITCH POSITION

Test	Switch
Open Drain Disable Low Enable Low	Closed
All Other Test	Open

#### DEFINITIONS:

CL = Load capacitance; includes jig and probe capacitance.  
RT = Termination resistance; should be equal to ZOUT of the Pulse Generator.

2581 tbt 08

### SET-UP, HOLD AND RELEASE TIMES

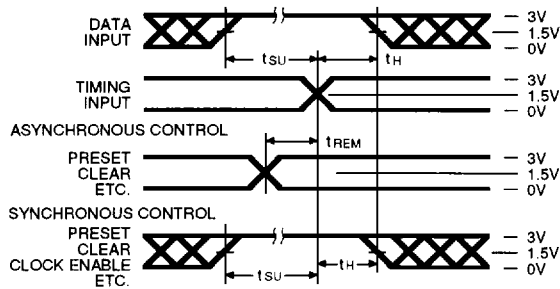

### PULSE WIDTH

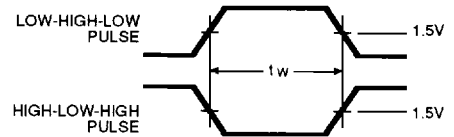

### PROPAGATION DELAY

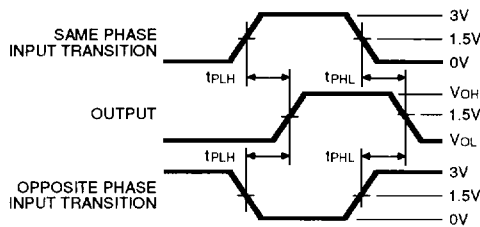

### ENABLE AND DISABLE TIMES

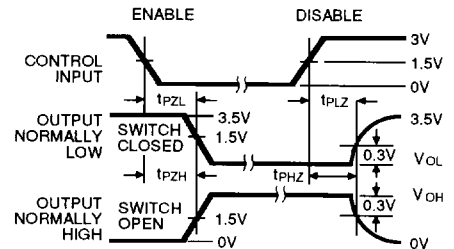

#### NOTES

- Diagram shown for input Control Enable-LOW and input Control Disable-HIGH.
- Pulse Generator for All Pulses: Rate  $\leq 1.0$  MHz;  $Z_0 \leq 50\Omega$ ;  $t_r \leq 2.5$ ns;  $t_f \leq 2.5$ ns.

2581 drw 04

ORDERING INFORMATION

