

Rail-to-Rail Output

Low Voltage, High Slew Rate, Wide Bandwidth

Dual Operational Amplifiers

FEATURES

- CMOS rail to rail output
- 2.7 to 5.5V single supply operation
- Gain-Bandwidth Product : 12MHz
- High slew rate : 6V/ μ s
- No crossover distortion
- Space saving SOP8 package
- Cost effective
- Pin assignments is the same as the general-purpose dual operational amplifiers

APPLICATIONS

- Active filters
- Servo amplifier
- Multimedia system
- Digital to Analog Converter buffers
- Laptop 、 Set-Top BOX
- Microphone preamplifier
- Cross-reference to low voltage application :
NJM2100, BA4510
TLV2632, TLV2772
TS462

DESCRIPTION

The MS2100 is high slew rate CMOS operation amplifier optimize for low voltage, single supply operation. It designed to be used for general purpose amplifier of general electronic equipment for consumer appliances.

BLOCK DIAGRAM

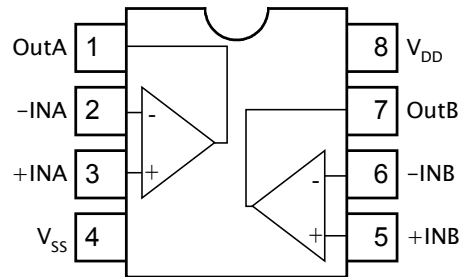

PIN CONFIGURATION

Symbol	Pin	Description
OutA	1	output A
-INA	2	inverting input A
+INA	3	non-inverting input A
V _{SS}	4	negative supply
+INB	5	non-inverting input B
-INB	6	inverting input B
OutB	7	output B
V _{DD}	8	positive supply

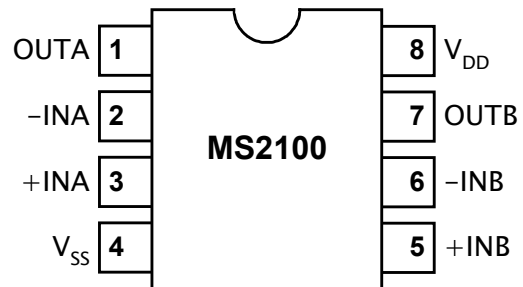

ORDERING INFORMATION

Package	Part number	Packaging Marking	Transport Media
8-Pin SOP	MS2100TR	MS2100	2.5k Units Tape and Reel
8-Pin SOP	MS2100U	MS2100	100 Units Tube
8-Pin SOP (lead free)	MS2100GTR	MS2100 (G)	2.5k Units Tape and Reel
8-Pin SOP (lead free)	MS2100GU	MS2100 (G)	100 Units Tube

RoHS Compliance

ABSOLUTE MAXIMUM RATINGS

Symbol	Parameter	Rating	Unit
V _{DD}	Supply Voltage	6	V
V _{ESD}	Electrostatic Handling	-4000 to 4000	V
T _{STG}	Storage Temperature Range	-65 to 150	°C
T _A	Operating Ambient Temperature Range	-40 to 85	°C
T _J	Maximum Junction Temperature	150	°C
T _S	Soldering Temperature, 10 seconds	260	°C
R _{THJA}	Thermal Resistance from Junction to Ambient in Free Air SOP8	210	°C/W

OPERATING RATINGS

Symbol	Parameter	Min	Typ	Max	Unit
V _{DD}	Supply Voltage	2.7	-	5.5	V

5V ELECTRICAL CHARACTERISTICS

($T_a=25^\circ\text{C}$, $V_{DD}=5\text{V}$, $V_{SS}=0\text{V}$, $V_{CM}=V_O=V_{DD}/2$; unless otherwise specified)

Symbol	Parameter	Conditions	Min	Typ	Max	Unit
DC Characteristics						
I_Q	Quiescent current	Dual Amplifiers	-	2.6	-	mA
V_{OS}	Input Offset Voltage		-	1	5	mV
CMRR	Common Mode Rejection Ratio	$0 \leq V_{CM} \leq 4\text{V}$	65	75	-	dB
PSRR	Power supply rejection ratio	Ripple = -20dBV, 100Hz	-	70	-	dB
CS	Cannel separation	$f = 10\text{kHz}$	-	78	-	dB
V_{CM}	Common mode voltage	$\text{CMRR} \geq 50\text{dB}$	0.2	-	4	V
V_O	Output voltage swing	$R_L \geq 2.5\text{k}\Omega$	-	$V_{DD}-25$	$V_{DD}-15$	mV
AC Characteristics						
SR	Slew rate		-	6	-	V/ μs
GBWP	Gain bandwidth product		-	12	-	MHz
THD+N	Total harmonic distortion plus noise	$f = 1\text{kHz}$, $A_v = -1$ $R_L > 10\text{k}$, $V_{in} = 4\text{Vpp}$	-	-75	-70	dB

2.7V ELECTRICAL CHARACTERISTICS

($T_a=25^\circ\text{C}$, $V_{DD}=2.7\text{V}$, $V_{SS}=0\text{V}$, $V_{CM}=V_O=V_{DD}/2$; unless otherwise specified)

Symbol	Parameter	Test conditions	Min	Typ	Max	Unit
DC Characteristics						
I_Q	Quiescent current	Dual Amplifiers	-	2.1	-	mA
V_{OS}	Input offset voltage		-	1	5	mV
CMRR	Common mode rejection ratio	$0 \leq V_{CM} \leq 1.7\text{V}$	57	67	-	dB
PSRR	Power supply rejection ratio	Ripple = -20dBV, 100Hz	-	57	-	dB
CS	Cannel separation	$f = 10\text{kHz}$	-	78	-	dB
V_{CM}	Common mode voltage	$\text{CMRR} \geq 50\text{dB}$	0.2	-	1.7	V
V_O	Output voltage swing	$R_L \geq 2.5\text{k}\Omega$		$V_{DD}-70$	$V_{DD}-60$	mV
AC Characteristics						
SR	Slew rate		-	5	-	V/ μs
GBWP	Gain bandwidth product		-	11	-	MHz
THD+N	Total harmonic distortion plus noise	$f = 1\text{kHz}$, $A_v = -1$ $R_L > 10\text{k}$, $V_{in} = 2\text{Vpp}$	-	-70	-65	dB

TYPICAL PERFORMANCE CHARACTERISTICS

($T_a=25^\circ\text{C}$; unless otherwise specified)

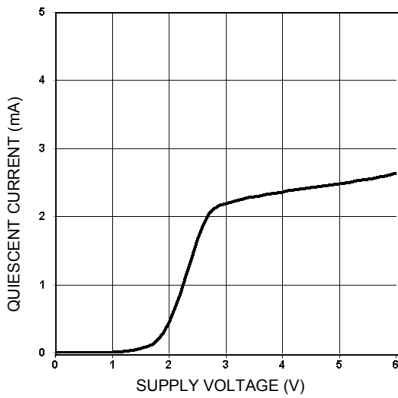

Quiescent current vs. supply voltage

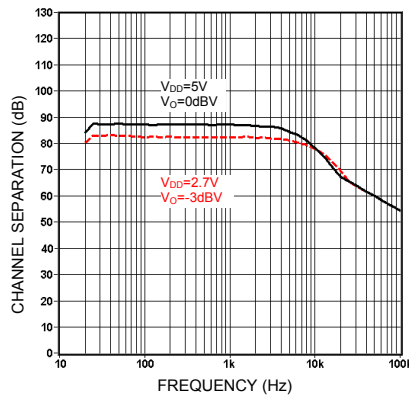

Channel separation vs. frequency

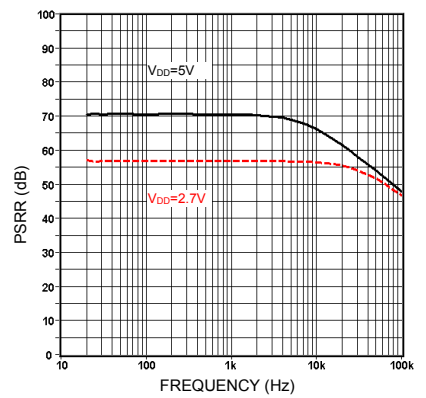

PSRR vs. frequency

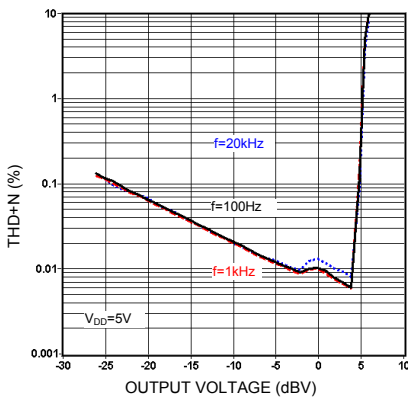

THD+N vs. output voltage

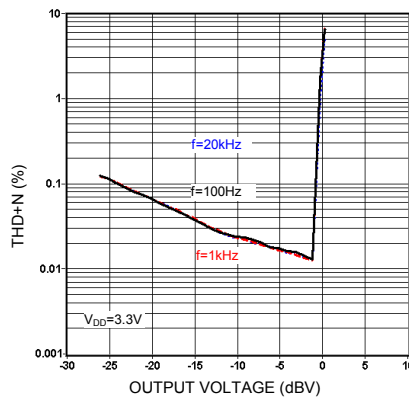

THD+N vs. output voltage

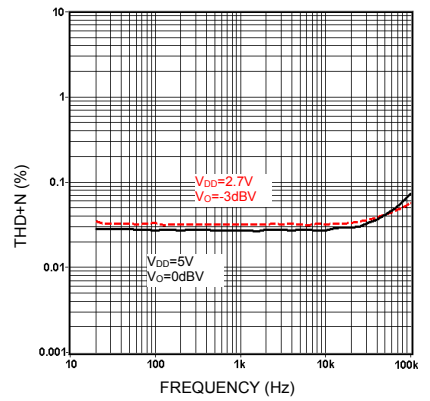

THD+N vs. frequency

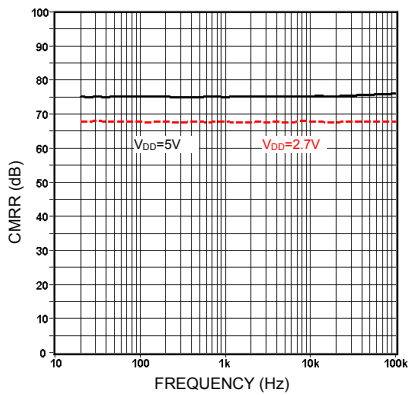

CMRR vs. frequency

APPLICATION INFORMATION (Single Supply)

Voltage Follower

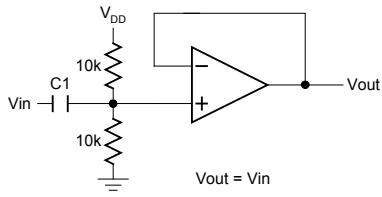

Difference Amplifier

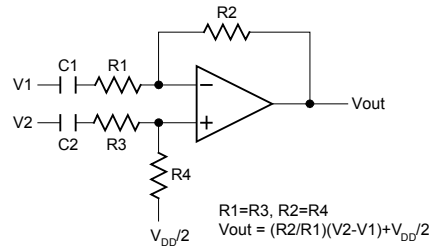

Inverting Amplifier

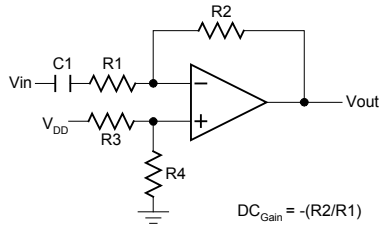

Simple High-Pass Filter

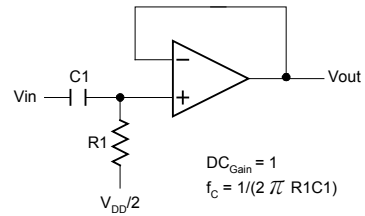

Simple Low-Pass Filter

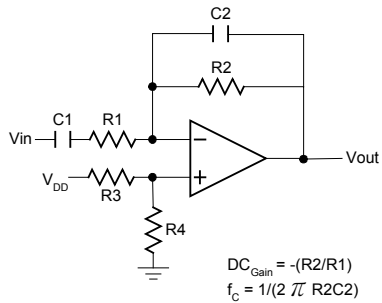

2nd Order Multiple Feedback Low-Pass Filter

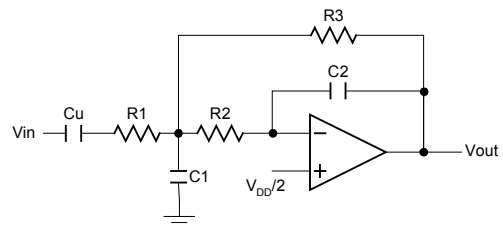

EXTERNAL DIMENSIONS

SOP8

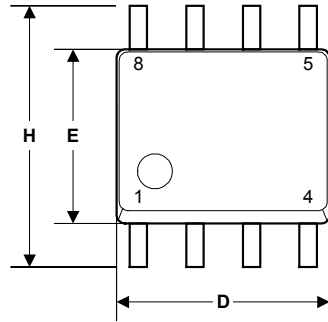

Symbol	Dimension in mm		Dimension in inch	
	Min	Max	Min	Max
A	1.35	1.75	0.0532	0.0688
A1	0.10	0.25	0.0040	0.0098
B	0.33	0.51	0.013	0.020
C	0.19	0.25	0.0075	0.0098
D	4.80	5.00	0.1890	0.1968
H	5.80	6.20	0.2284	0.2440
E	3.80	4.00	0.1497	0.1574
e	1.27 BSC		0.050 BSC	
L	0.40	1.27	0.016	0.050

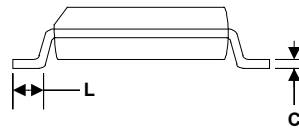
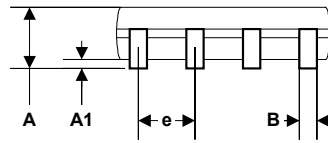

TAPE AND REEL (Unit : mm)

SOP8

