

Fast CMOS 16-Bit Latched Transceivers
Product Features

- Functionally compatible with FCT3, LVT, and 74 series 16543 families of products
- Tri-State outputs
- 5V Tolerant inputs and outputs
- 2.0V-3.6V Vcc supply operation
- Balanced sink and source output drives (24mA)
- Low ground bounce outputs
- Supports live insertion
- ESD Protection exceeds 2000V, Human Body Model
200V, Machine Model
- Packages available:
 - 56-pin 240-mil wide plastic TSSOP (A56)
 - 56-pin 300-mil wide plastic SSOP (V56)

Product Description

Pericom Semiconductor's PI74LCX series of logic circuits are produced using the Company's advanced 0.6 micron CMOS technology achieving high speed while maintaining low power operation.

The PI74LCX16543 is 16-bit latched transceivers organized with two sets of eight D-type latches with separate input and output controls for each set. For data flow from A to B, for example, the A-to-B Enable (\overline{xCEAB}) input must be LOW in order to enter data from xAx or to take data from xBx , as indicated in the Truth Table. With \overline{xCEAB} LOW, a LOW signal makes the A-to-B latches transparent; a subsequent LOW-to-HIGH transition of the \overline{xLEAB} signal puts the A latches in the storage mode and their outputs no longer change the A inputs. With \overline{xCEAB} and \overline{xOEAB} both LOW, the 3-state B output buffers are active and reflect the data present at the output of the A latches. Control of data from B to A is similar, but uses the \overline{xCEAB} , \overline{xLEAB} , and \overline{xOEAB} inputs.

The PI74LCX16543 can be driven from either 3.3V or 5.0V devices allowing this device to be used as a translator in a mixed 3.3V/5.0V system.

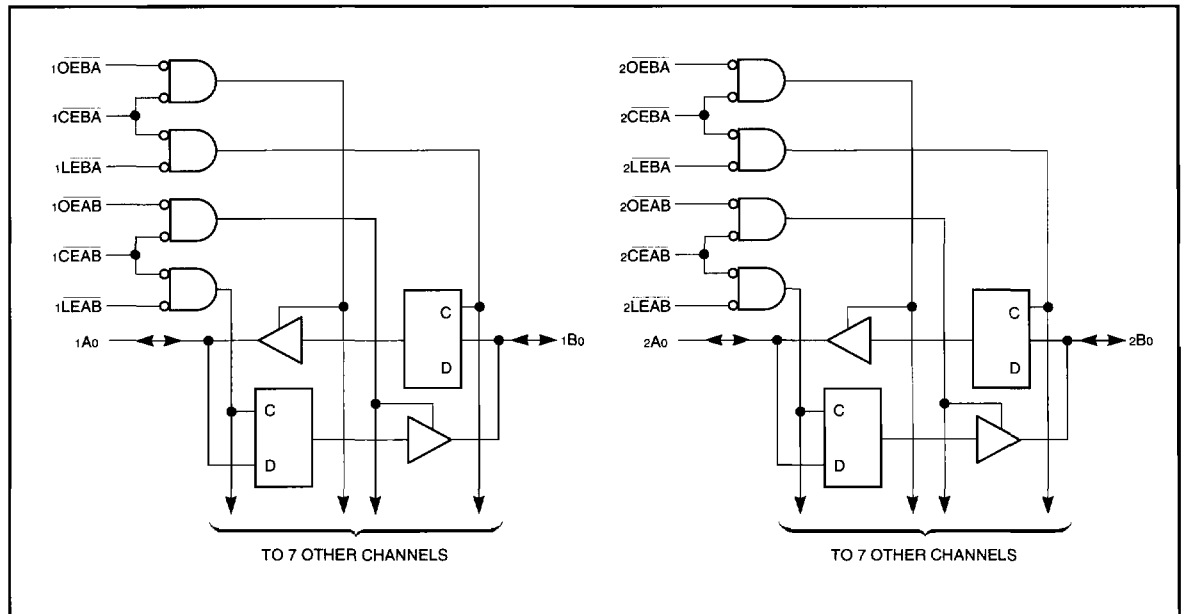
Logic Block Diagram

Product Pin Description

Pin Name	Description
\overline{xOEAB}	A-to-B Output Enable Input (Active LOW)
\overline{xOEBA}	B-to-A Output Enable Input (Active LOW)
\overline{xCEAB}	A-to-B Enable Input (Active LOW)
\overline{xCEBA}	B-to-A Enable Input (Active LOW)
\overline{xLEAB}	A-to-B Latch Enable Input (Active LOW)
\overline{xLEBA}	B-to-A Latch Enable Input (Active LOW)
xAx	A-to-B Data Inputs or B-to-A 3-State Outputs
xBx	B-to-A Data Inputs or B-to-A 3-State Outputs
GND	Ground
Vcc	Power

Truth Table

Inputs			Latch Status	Output Buffers
\overline{xCEAB}	\overline{xLEAB}	\overline{xOEAB}	xAx to xBx	xBx
H	X	X	Storing	High Z
X	H	X	Storing	—
X	X	H	—	High Z
L	L	L	Transparent	Current A Input
L	H	L	Storing	Previous* A Input

Note:

*Before \overline{xLEAB} Low-to-High transition.

H = High Voltage Level

L = Low Voltage Level

X = Don't Care or Irrelevant

Z = High Impedance

A-to-B data flow shown. B-to-A flow control is the same, except using \overline{xCEBA} , \overline{xLEBA} , and \overline{xOEBA} .

Product Pin Configuration

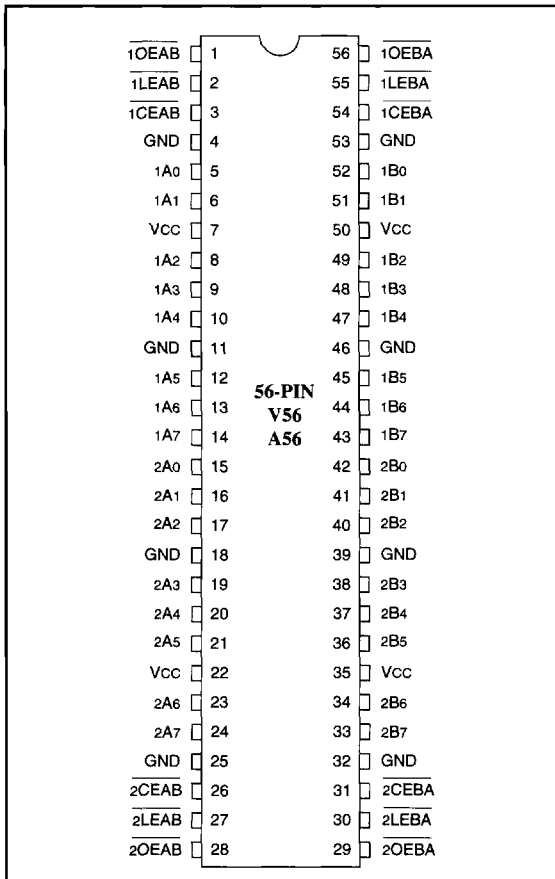

Maximum Ratings

(Above which the useful life may be impaired. For user guidelines, not tested.)

Storage Temperature	-65°C to +150°C
Ambient Temperature with Power Applied	-40°C to +85°C
Supply Voltage to Ground Potential (Inputs & Vcc Only)	-0.5V to +7.0V
Supply Voltage to Ground Potential (Outputs & D/O Only)	-0.5V to +7.0V
DC Input Voltage	-0.5V to +7.0V
DC Output Current	120 mA
Power Dissipation	1.0W

Note:
Stresses greater than those listed under MAXIMUM RATINGS may cause permanent damage to the device. This is a stress rating only and functional operation of the device at these or any other conditions above those indicated in the operational sections of this specification is not implied. Exposure to absolute maximum rating conditions for extended periods may affect reliability.

Recommended Operating Conditions

Symbol	Parameter	Min.	Max.	Units		
V _{CC}	Supply Voltage	Operating	2.0	3.6	V	
		Data Retention	1.5	3.6		
V _I	Input Voltage	0	5.5			
V _O	Output Voltage	HIGH or LOW State	0	V _{CC}		
		TRI-State	0	5.5		
I _{OH} /I _{OL}	Output Current	V _{CC} = 3.0V-3.6V	—	±24		mA
		V _{CC} = 2.7V	—	±12		
T _A	Free-Air Operating Temperature	-40	+85	°C		
Δt/ΔV	Input Edge Rate	V = 0.8V-2.0V, V _{CC} = 3.0V		0	10	ns/V

DC Electrical Characteristics (Over the Operating Range, $T_A = -40^{\circ}\text{C}$ to $+85^{\circ}\text{C}$, $V_{CC} = 2.7\text{V}$ to 3.6V)

Parameters	Description	Test Conditions ⁽¹⁾		Min.	Typ ⁽²⁾	Max.	Units
V_{IH}	Input HIGH Voltage	Guaranteed Logic HIGH Level		2.0	—	—	V
V_{IL}	Input LOW Voltage	Guaranteed Logic LOW Level		—	—	0.8	
V_{OH}	Output HIGH Voltage	$V_{CC} = 2.7\text{-}3.6$	$I_{OH} = -0.1\text{mA}$	$V_{CC}-0.2$	—	—	
		$V_{CC} = 2.7$	$I_{OH} = -12\text{mA}$	2.2	—	—	
		$V_{CC} = 3.0$	$I_{OH} = -18\text{mA}$	2.4	—	—	
			$I_{OH} = -24\text{mA}$	2.2	—	—	
V_{OL}	Output LOW Voltage	$V_{CC} = 2.7\text{-}3.6$	$I_{OL} = 0.1\text{mA}$	—	—	0.2	
		$V_{CC} = 2.7$	$I_{OL} = 12\text{mA}$	—	—	0.4	
		$V_{CC} = 3.0$	$I_{OL} = 16\text{mA}$	—	—	0.4	
			$I_{OL} = 24\text{mA}$	—	—	0.55	
V_{IK}	Clamp Diode Voltage	$V_{CC} = \text{Min.}, I_{IN} = -18\text{mA}$		—	-0.7	-1.2	
I_I	Input Leakage Current	$0 \leq V_I \leq 5.5\text{V}$	$V_{CC} = 2.7\text{-}3.6$	—	—	± 5	μA
I_{OZ}	Tri-State Output Leakage	$0 \leq V_O \leq 5.5\text{V}$ $V_I = V_{IH}$ or V_{IL}	$V_{CC} = 2.7\text{-}3.6$	—	—	± 5	
I_{OFF}	Power Down Disable	$V_{CC} = 0\text{V}, V_{IN}$ or $V_{OUT} \leq 5.5\text{V}$		—	—	10	
I_{CC}	Quiescent Power Supply Current	$V_{CC} = \text{Max.}$	$V_{IN} = \text{GND}$ or V_{CC}	—	0.1	10	
ΔI_{CC}	Quiescent Power Supply Current TTL Inputs HIGH	$V_{CC} = \text{Max.}$	$V_{IN} = V_{CC} - 0.6\text{V}^{(3)}$	—	—	500	

Notes:

- For Max. or Min. conditions, use appropriate value specified under Electrical Characteristics for the applicable device type.
- Typical values are at $V_{CC} = 3.3\text{V}$, $+25^{\circ}\text{C}$ ambient.
- Per TTL driven input; all other inputs at V_{CC} or GND .

Capacitance

Parameters	Description	Test Conditions	Typ.	Units
C_{IN}	Input Capacitance	$V_{CC} = \text{Open}, V_I = 0\text{V}$ or V_{CC}	7	pF
C_{OUT}	Output Capacitance	$V_{CC} = 3.3\text{V}, V_I = 0\text{V}$ or V_{CC}	8	
C_{PD}	Power Dissipation Capacitance	$V_{CC} = 3.3\text{V}, V_I = 0\text{V}$ or $V_{CC}, F = 10\text{MHz}$	20	

Switching Characteristics over Operating Range

Parameters	Description	Conditions	V _{CC} = 3.3V ± 0.3V		V _{CC} = 2.7V		Units
			Min.	Max.	Min.	Max.	
t _{PHL} t _{PLH}	Propagation Delay A _n to B _n or B _n to A _n	C _L = 50pF R _L = 500Ω	1.5	5.2	1.5	6.0	ns
t _{PHL} t _{PLH}	Propagation Delay LEBA _n to A _n or LEAB _n to B _n		1.5	6.5	1.5	7.5	
t _{PZL} t _{PZH}	Output Enable Time OEBA _n or OEAB _n to A _n or B _n CEBA _n or CEAB _n to A _n or B _n		1.5	6.5	1.5	7.0	
t _{PLZ} t _{PHZ}	Output Disable Time OEBA _n or OEAB _n to A _n or B _n CEBA _n or CEAB _n to A _n or B _n		1.5	6.5	1.5	7.0	
t _s	Setup Time, HIGH or LOW Data to LExx _n		2.5	—	2.5	—	
t _h	Hold Time, HIGH or LOW Data to LExx _n		1.5	—	1.5	—	
t _w	Pulse Width, Latch Enable, LOW		3.0	—	3.0	—	
t _{SK(0)}	Output to Output Skew ⁽¹⁾		—	1.0	—	—	

Notes:

1. Skew between any two outputs, of the same package, switching in the same direction.

Dynamic Switching Characteristics (T_A = +25°C)

Parameters	Description	Test Conditions ⁽¹⁾	Typ.	Units
V _{OLP}	Dynamic LOW Peak Voltage	V _{CC} = 3.3V, C _L = 50 pF V _{IH} = 3.3V, V _{IL} = 0V	0.8	V
V _{OLV}	Dynamic LOW Valley Voltage	V _{CC} = 3.3V, C _L = 50 pF V _{IH} = 3.3V, V _{IL} = 0V		

Note:

1. Measured with n-1 outputs switching from High-to-Low or Low-to-High. The remaining output is measured in the LOW state.