

# SN54BCT2827C, SN74BCT2827C 10-BIT BUS/MOS MEMORY DRIVERS WITH 3-STATE OUTPUTS

SCBS007E - APRIL 1987 - REVISED NOVEMBER 1993

- BICMOS Design Substantially Reduces  $I_{CCZ}$
- Output Ports Have Equivalent 25- $\Omega$  Resistors; No External Resistors Are Required
- Specifically Designed to Drive MOS DRAMs
- 3-State Outputs Drive Bus Lines or Buffer Memory Address Registers
- Flow-Through Architecture Optimizes PCB Layout
- Power-Up High-Impedance State
- ESD Protection Exceeds 2000 V Per MIL-STD-883C, Method 3015
- Package Options Include Plastic Small-Outline (DW) Packages, Ceramic Chip Carriers (FK) and Flatpacks (W), and Standard Plastic and Ceramic 300-mil DIPs (JT, NT)

## description

These 10-bit buffers and bus drivers are specifically designed to drive the capacitive input characteristics of MOS DRAMs. They provide high-performance bus interface for wide data paths or buses carrying parity.

The 3-state control gate is a 2-input AND gate with active-low inputs so if either output-enable ( $\overline{OE1}$  or  $\overline{OE2}$ ) input is high, all ten outputs are in the high-impedance state. The outputs are also in the high-impedance state during power-up and power-down conditions. The outputs remain in the high-impedance state while the device is powered down.

The SN54BCT2827C is characterized for operation over the full military temperature range of  $-55^{\circ}\text{C}$  to  $125^{\circ}\text{C}$ . The SN74BCT2827C is characterized for operation from  $0^{\circ}\text{C}$  to  $70^{\circ}\text{C}$ .

SN54BCT2827C . . . JT OR W PACKAGE  
SN74BCT2827C . . . DW OR NT PACKAGE  
(TOP VIEW)

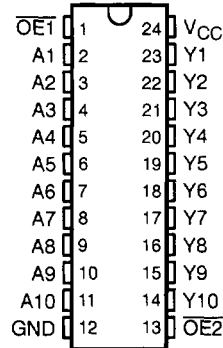

SN54BCT2827C . . . FK PACKAGE  
(TOP VIEW)

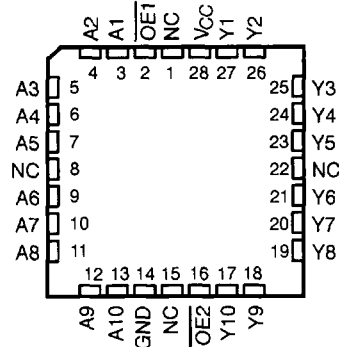

NC - No internal connection

FUNCTION TABLE

INPUTS			OUTPUT
$\overline{OE1}$	$\overline{OE2}$	A	Y
L	L	L	L
L	L	H	H
H	X	X	Z
X	H	X	Z

PRODUCTION DATA Information is current as of publication date. Products conform to specifications per the terms of Texas Instruments standard warranty. Production processing does not necessarily include testing of all parameters.

 **TEXAS  
INSTRUMENTS**

POST OFFICE BOX 855303 • DALLAS, TEXAS 75265

Copyright © 1993, Texas Instruments Incorporated

2-143

**SN54BCT2827C, SN74BCT2827C**  
**10-BIT BUS/MOS MEMORY DRIVERS**  
**WITH 3-STATE OUTPUTS**

SCBS007E - APRIL 1987 - REVISED NOVEMBER 1993

**logic symbol†**

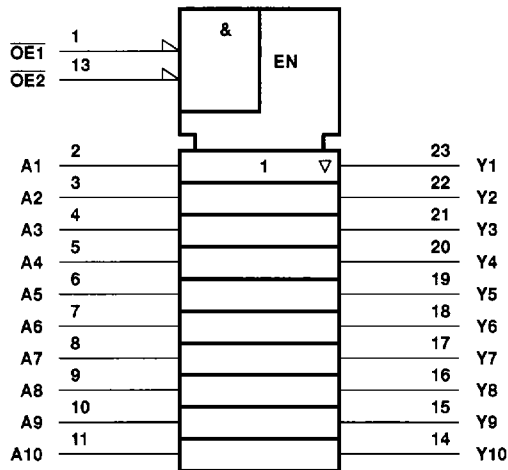

**logic diagram (positive logic)**

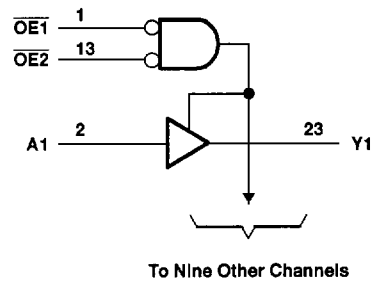

† This symbol is in accordance with ANSI/IEEE Std 91-1984 and IEC Publication 617-12.

Pin numbers shown are for the DW, JT, NT, and W packages.

**schematic of each output**

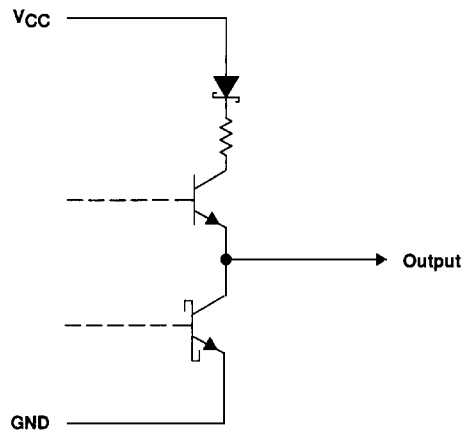

**SN54BCT2827C, SN74BCT2827C**  
**10-BIT BUS/MOS MEMORY DRIVERS**  
**WITH 3-STATE OUTPUTS**

SCBS007E – APRIL 1987 – REVISED NOVEMBER 1993

**absolute maximum ratings over operating free-air temperature range (unless otherwise noted)†**

Supply voltage range, $V_{CC}$ .....	-0.5 V to 7 V
Input voltage range, $V_I$ (see Note 1) .....	-0.5 V to 7 V
Voltage range applied to any output in the disabled or power-off state, $V_O$ .....	-0.5 V to 5.5 V
Voltage range applied to any output in the high state, $V_O$ .....	-0.5 V to $V_{CC}$
Input clamp current, $I_{IK}$ .....	-30 mA
Current into any output in the low state .....	24 mA
Operating free-air temperature range: SN54BCT2827C .....	-55°C to 125°C
SN74BCT2827C .....	0°C to 70°C
Storage temperature range .....	-65°C to 150°C

† Stresses beyond those listed under "absolute maximum ratings" may cause permanent damage to the device. These are stress ratings only, and functional operation of the device at these or any other conditions beyond those indicated under "recommended operating conditions" is not implied. Exposure to absolute-maximum-rated conditions for extended periods may affect device reliability.

NOTE 1: The input negative-voltage rating may be exceeded if the input clamp current rating is observed.

**recommended operating conditions**

		SN54BCT2827C			SN74BCT2827C			UNIT
		MIN	NOM	MAX	MIN	NOM	MAX	
$V_{CC}$	Supply voltage	4.5	5	5.5	4.5	5	5.5	V
$V_{IH}$	High-level input voltage	2			2			V
$V_{IL}$	Low-level input voltage			0.8			0.8	V
$I_{IK}$	Input clamp current			-18			-18	mA
$I_{OH}$	High-level output current			-1			-1	mA
$I_{OL}$	Low-level output current			12			12	mA
$T_A$	Operating free-air temperature	-55		125	0		70	°C

**electrical characteristics over recommended operating free-air temperature range (unless otherwise noted)**

PARAMETER	TEST CONDITIONS	SN54BCT2827C			SN74BCT2827C			UNIT
		MIN	TYP‡	MAX	MIN	TYP‡	MAX	
$V_{IK}$	$V_{CC} = 4.5$ V, $I_I = -18$ mA			-1.2			-1.2	V
$V_{OH}$	$V_{CC} = 4.5$ V to 5.5 V, $I_{OH} = -1$ mA	$V_{CC}-2$			$V_{CC}-2$			V
$V_{OL}$	$V_{CC} = 4.5$ V	$I_{OL} = 1$ mA	0.15	0.5	0.15	0.5		V
		$I_{OL} = 12$ mA	0.35	0.8	0.35	0.8		
$I_{OZH}$	$V_{CC} = 5.5$ V, $V_O = 2.7$ V			20			20	µA
$I_{OZL}$	$V_{CC} = 5.5$ V, $V_O = 0.5$ V			-20			-20	µA
$I_{OL(sink)}$	$V_{CC} = 4.5$ V, $V_O = 2$ V			50			50	mA
$I_I$	$V_{CC} = 5.5$ V, $V_I = 7$ V			0.1			0.1	mA
$I_{IH}$	$V_{CC} = 5.5$ V, $V_I = 2.7$ V			20			20	µA
$I_{IL}$	$V_{CC} = 5.5$ V, $V_I = 0.5$ V			-0.2			-0.2	mA
$I_{OS}§$	$V_{CC} = 5.5$ V, $V_O = 2.25$ V	-30		-112	-30		-112	mA
$I_{CCL}$	$V_{CC} = 5.5$ V, Outputs open		28	40		28	40	mA
$I_{CCZ}$	$V_{CC} = 5.5$ V, Outputs open		3.8	6		3.8	6	mA
$C_i$	$V_{CC} = 5$ V, $V_I = 2.5$ V or 0.5 V		5			5		pF
$C_o$	$V_{CC} = 5$ V, $V_I = 2.5$ V or 0.5 V		8			8		pF

‡ All typical values are at  $V_{CC} = 5$  V,  $T_A = 25$ °C.

§ The output conditions have been chosen to produce a current that closely approximates one half of the true short circuit output current,  $I_{OS}$ .



POST OFFICE BOX 655303 • DALLAS, TEXAS 75265

**SN54BCT2827C, SN74BCT2827C**  
**10-BIT BUS/MOS MEMORY DRIVERS**  
**WITH 3-STATE OUTPUTS**

SCBS007E – APRIL 1987 – REVISED NOVEMBER 1993

**switching characteristics (see Note 2)**

PARAMETER	FROM (INPUT)	TO (OUTPUT)	V <sub>CC</sub> = 5 V, C <sub>L</sub> = 50 pF, R <sub>1</sub> = 500 Ω, R <sub>2</sub> = 500 Ω, T <sub>A</sub> = 25°C			V <sub>CC</sub> = 4.5 V to 5.5 V, C <sub>L</sub> = 50 pF, R <sub>1</sub> = 500 Ω, R <sub>2</sub> = 500 Ω, T <sub>A</sub> = MIN to MAX†				UNIT
			BCT2827C			SN54BCT2827C		SN74BCT2827C		
			MIN	TYP	MAX	MIN	MAX	MIN	MAX	
t <sub>PLH</sub>	A	Y	0.9	3.6	5.2	0.9	6.6	0.9	6	ns
t <sub>PHL</sub>			2	5.1	7.2	2	8.2	2	7.8	
t <sub>PZH</sub>	$\overline{OE}$	Y	2.8	5.6	8	2.8	10.7	2.8	10.7	ns
t <sub>PZL</sub>			5	8.9	11	5	13.7	5	12.9	
t <sub>PHZ</sub>	$\overline{OE}$	Y	3.2	6.7	8.5	3.2	14	3.2	13	ns
t <sub>PLZ</sub>			2.7	5.3	10.5	2.7	11	2.7	10	

† For conditions shown as MIN or MAX, use the appropriate value specified under recommended operating conditions.

NOTE 2: Load circuits and voltage waveforms are shown in Section 1.

