

SN54ACT11, SN74ACT11 TRIPLE 3-INPUT POSITIVE-AND GATES

SCAS531A – AUGUST 1995 – REVISED APRIL 1996

- Inputs Are TTL-Voltage Compatible
- EPIC™ (Enhanced-Performance Implanted CMOS) 1- μ m Process
- Package Options Include Plastic Small-Outline (D), Shrink Small-Outline (DB), and Thin Shrink Small-Outline (PW) Packages, Ceramic Chip Carriers (FK) and Flatpacks (W), and Standard Plastic (N) and Ceramic (J) DIPS

description

The 'ACT11 contain three independent 3-input AND gates. The devices perform the Boolean functions $Y = A \cdot B \cdot C$ or $Y = \overline{A} + \overline{B} + \overline{C}$ in positive logic.

The SN54ACT11 is characterized for operation over the full military temperature range of -55°C to 125°C . The SN74ACT11 is characterized for operation from -40°C to 85°C .

FUNCTION TABLE
(each gate)

INPUTS			OUTPUT Y
A	B	C	
H	H	H	H
L	X	X	L
X	L	X	L
X	X	L	L

logic symbol†

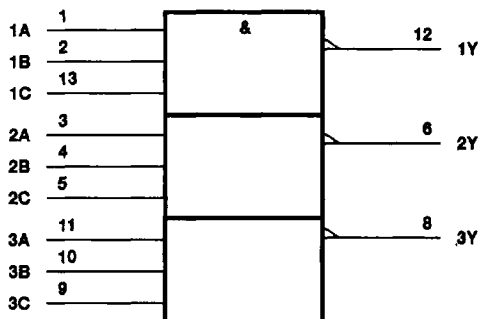

† This symbol is in accordance with ANSI/IEEE Std 91-1984 and IEC Publication 617-12.
Pin numbers shown are for the D, DB, J, N, PW, and W packages.

SN54ACT11 ... J OR W PACKAGE
SN74ACT11 ... D, DB, N, OR PW PACKAGE
(TOP VIEW)

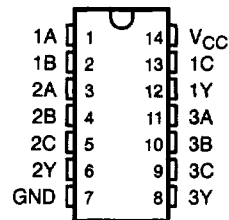

SN54ACT11 ... FK PACKAGE
(TOP VIEW)

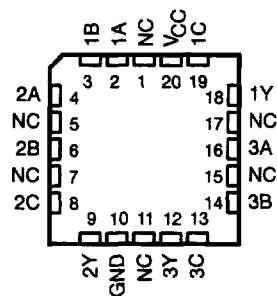

NC – No internal connection

logic diagram, each gate (positive logic)

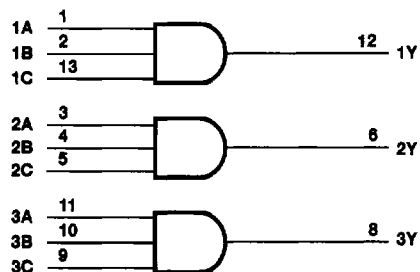

EPIC is a trademark of Texas Instruments Incorporated.

PRODUCTION DATA Information is current as of publication date. Products conform to specifications per the terms of Texas Instruments standard warranty. Production processing does not necessarily include testing of all parameters.

 **TEXAS
INSTRUMENTS**

POST OFFICE BOX 655303 • DALLAS, TEXAS 75266

Copyright © 1996, Texas Instruments Incorporated

SN54ACT11, SN74ACT11

TRIPLE 3-INPUT POSITIVE-AND GATES

SCAS531A – AUGUST 1995 – REVISED APRIL 1996

absolute maximum ratings over operating free-air temperature range (unless otherwise noted)†

Supply voltage range, V_{CC}	–0.5 V to 7 V
Input voltage range, V_I (see Note 1)	–0.5 V to $V_{CC} + 0.5$ V
Output voltage range, V_O (see Note 1)	–0.5 V to $V_{CC} + 0.5$ V
Input clamp current, I_{IK} ($V_I < 0$ or $V_I > V_{CC}$)	±20 mA
Output clamp current, I_{OK} ($V_O < 0$ or $V_O > V_{CC}$)	±20 mA
Continuous output current, I_O ($V_O = 0$ to V_{CC})	±50 mA
Continuous current through V_{CC} or GND	±200 mA
Maximum power dissipation at $T_A = 55^\circ\text{C}$ (in still air) (see Note 2):	
D package	1.25 W
DB package	0.5 W
N package	1.1 W
PW package	0.5 W
Storage temperature range, T_{stg}	–65°C to 150°C

† Stresses beyond those listed under "absolute maximum ratings" may cause permanent damage to the device. These are stress ratings only, and functional operation of the device at these or any other conditions beyond those indicated under "recommended operating conditions" is not implied. Exposure to absolute-maximum-rated conditions for extended periods may affect device reliability.

- NOTES: 1. The input and output voltage ratings may be exceeded if the input and output current ratings are observed.
 2. The maximum package power dissipation is calculated using a junction temperature of 150°C and a board trace length of 750 mils, except for the N package, which has a trace length of zero.

recommended operating conditions (see Note 3)

	MIN	MAX	MIN	MAX	UNIT
V_{CC} Supply voltage	4.5	5.5	4.5	5.5	V
V_{IH} High-level input voltage	2		2		V
V_{IL} Low-level input voltage		0.8		0.8	V
V_I Input voltage	0	V_{CC}	0	V_{CC}	V
V_O Output voltage	0	V_{CC}	0	V_{CC}	V
I_{OH} High-level output current		–24		–24	mA
I_{OL} Low-level output current		24		24	mA
$\Delta t/\Delta v$ Input transition rise or fall rate	0	8	0	8	ns/V
T_A Operating free-air temperature	–55	125	–40	85	°C

NOTE 3: Unused inputs must be held high or low to prevent them from floating.

SN54ACT11, SN74ACT11 TRIPLE 3-INPUT POSITIVE-AND GATES

SCAS531A - AUGUST 1995 - REVISED APRIL 1996

electrical characteristics over recommended operating free-air temperature range (unless otherwise noted)

PARAMETER	TEST CONDITIONS	V _{CC}	T _A = 25°C			SN54ACT11		SN74ACT11		UNIT
			MIN	TYP	MAX	MIN	MAX	MIN	MAX	
V _{OH}	I _{OH} = -50 μA	4.5 V	4.4	4.49		4.4		4.4	V	
		5.5 V	5.4	5.49		5.4		5.4		
	I _{OH} = -24 mA	4.5 V	3.86			3.7		3.76		
		5.5 V	4.86			4.7		4.76		
	I _{OH} = -50 mA†	5.5 V				3.85				
I _{OH} = -75 mA†	5.5 V						3.85			
V _{OL}	I _{OL} = 50 μA	4.5 V		0.001	0.1		0.1		0.1	
		5.5 V		0.001	0.1		0.1		0.1	
	I _{OL} = 24 mA	4.5 V			0.36		0.5		0.44	
		5.5 V			0.36		0.5		0.44	
	I _{OL} = 50 mA†	5.5 V					1.65			
I _{OL} = 75 mA†	5.5 V							1.65		
I _I	V _I = V _{CC} or GND	5.5 V			±0.1		±1		±1	μA
I _{CC}	V _I = V _{CC} or GND, I _O = 0	5.5 V			2		40		20	μA
ΔI _{CC} ‡	One input at 3.4 V, Other inputs at GND or V _{CC}	5.5 V			0.6		1.6		1.5	mA
C _i	V _I = V _{CC} or GND	5 V			2.6					pF

† Not more than one output should be tested at a time, and the duration of the test should not exceed 10 ms.

‡ This is the increase in supply current for each input that is at one of the specified TTL voltage levels rather than 0 V or V_{CC}.

switching characteristics over recommended operating free-air temperature range,
V_{CC} = 5 V ± 0.5 V (unless otherwise noted) (see Figure 1)

PARAMETER	FROM (INPUT)	TO (OUTPUT)	T _A = 25°C			SN54ACT11		SN74ACT11		UNIT
			MIN	TYP	MAX	MIN	MAX	MIN	MAX	
t _{PLH}	Any	Y	1.5	6	9.5	1	10.5	1	10.5	ns
t _{PHL}			1.5	6	9.5	1	10.5	1	10.5	

operating characteristics, V_{CC} = 5 V, T_A = 25°C

PARAMETER	TEST CONDITIONS	TYP	UNIT
C _{pd} Power dissipation capacitance	C _L = 50 pF, f = 1 MHz	20	pF

SN54ACT11, SN74ACT11 TRIPLE 3-INPUT POSITIVE-AND GATES

SCAS531A – AUGUST 1995 – REVISED APRIL 1996

PARAMETER MEASUREMENT INFORMATION

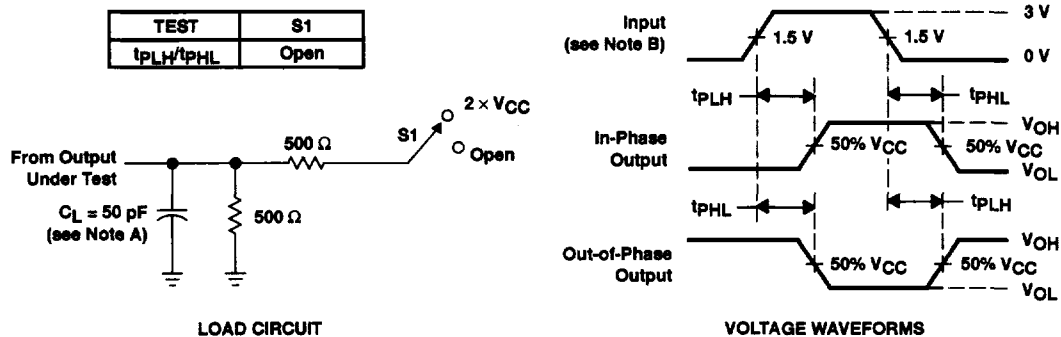

- NOTES: A. C_L includes probe and jig capacitance.
 B. All input pulses are supplied by generators having the following characteristics: $PRR \leq 1 \text{ MHz}$, $Z_O = 50 \Omega$, $t_r \leq 2.5 \text{ ns}$, $t_f \leq 2.5 \text{ ns}$.
 C. The outputs are measured one at a time with one input transition per measurement.

Figure 1. Load Circuit and Voltage Waveforms