



CD4016BM/CD4016BC Quad Bilateral Switch

General Description

The CD4016BM/CD4016BC is a quad bilateral switch intended for the transmission or multiplexing of analog or digital signals. It is pin-for-pin compatible with CD4066BM/CD4066BC.

Features

- Wide supply voltage range 3V to 15V
- Wide range of digital and analog switching $\pm 7.5 V_{PEAK}$
- "ON" resistance for 15V operation 400Ω (typ.)
- Matched "ON" resistance over 15V signal input $\Delta R_{ON} = 10\Omega$ (typ.)
- High degree of linearity 0.4% distortion (typ.)
@ $f_{IS} = 1 \text{ kHz}$, $V_{IS} = 5 V_{p-p}$,
 $V_{DD} - V_{SS} = 10V$, $R_L = 10 \text{ k}\Omega$
- Extremely low "OFF" switch leakage 0.1 nA (typ.)
@ $V_{DD} - V_{SS} = 10V$
 $T_A = 25^\circ\text{C}$

- Extremely high control input impedance 10¹²Ω (typ.)
- Low crosstalk between switches -50 dB (typ.)
@ $f_{IS} = 0.9 \text{ MHz}$, $R_L = 1 \text{ k}\Omega$
- Frequency response, switch "ON" 40 MHz (typ.)

Applications

- Analog signal switching/multiplexing
 - Signal gating
 - Squelch control
 - Chopper
 - Modulator/Demodulator
 - Commutating switch
- Digital signal switching/multiplexing
- CMOS logic implementation
- Analog-to-digital/digital-to-analog conversion
- Digital control of frequency, impedance, phase, and analog-signal gain

Schematic and Connection Diagrams

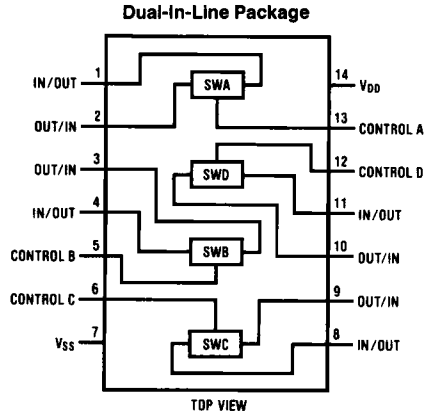
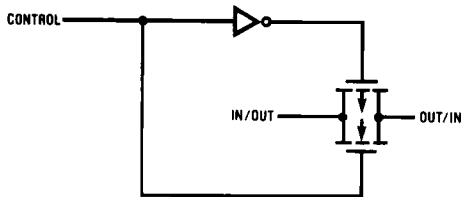

Order Number CD4016B

TL/F/5661-1