

AAHH00

Radiation Tolerant Quad 2-Input NAND Gate

PRELIMINARY DATA

DESCRIPTION

The AAHH00 is part of ASIC Advantage's family of Radiation Tolerant products aimed at the military and aerospace markets. The AAHH00 is a Radiation-Tolerant Quad 2 input NAND gate. It utilizes Bi-CMOS technology and is a replacement to the obsolete part 5962R9563701VXC.

FEATURES

- Tolerance to 200kRad(Si) Total Dose
- Latch-Up Free Design
- Input Compatible to LSTTL
VIL = 0.8V, VIH=VCC/2
- Low Power ICs
- Operating Temperature Range of -55°C to +125°C
- Input Compatibility to CMOS
Ii ≤ 5µA at VOL, VOH
- SEP Effective LET no Upsets: >100MeV-cm²/mg
- Immunity to SEU up to <5x10⁻¹⁶errors/Bit-Day
- Available in Die or 14-pin Ceramic Dual-In-Line FLATPACK package.

TRUTH TABLE

Inputs		Output
An	Bn	Yn
L	L	H
L	H	H
H	L	H
H	H	L

PIN CONFIGURATION:

14-pin CERAMIC DUAL-IN-LINE FLATPACK

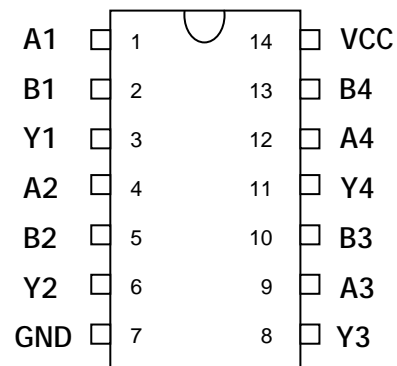

FUNCTIONAL DIAGRAM

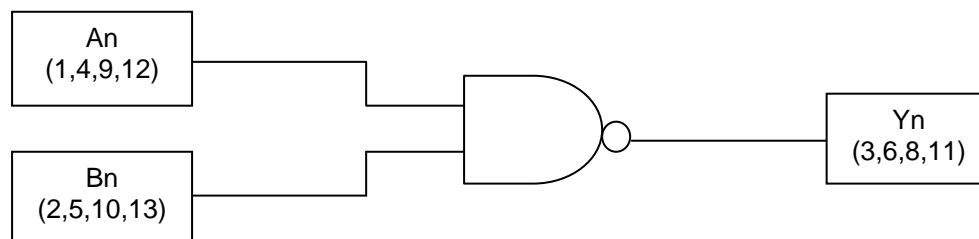

Radiation Tolerant AAHH00

Absolute Maximum Ratings

Supply voltage: -0.5V to 7V
 Input Voltage Range: -0.5V to VCC+0.5V
 Dc Input Current: \pm 10mA
 DC Drain Current: \pm 25mA
 Storage Temperature Range: -65°C to 150°C
 Lead Temperature Range: 265°C
 Junction Temperature: 175°C
 ESD Classification: Class 1

Reliability Information

TBD

Operating Conditions:

Supply Voltage: 4.5V to 5.5V
 Input rise and Fall Times: 100ns/Vmax
 Input Low Voltage (VIL): 0.0 to 0.8V
 Input High Voltage (VIH): VCC/2 to VCC
 Operating Temperature Range: -55°C to +125°C

DC ELECTRICAL CHARACTERISTICS							
PARAMETER	SYMBOL	CONDITION	GROUP	TEMPERATURE	LIMITS		UNIT
					MIN	MAX	
Quiescent Current	ICC	VCC=5.5V VIN=VCC or GND	1	25°C		10	μ A
			2, 3	-55°C, 125°C		200	μ A
Output Current (sink)	IOL	VCC=4.5V, VIH=4.5V VOUT=0.4V, VIL=0V	1	25°C	4.8		mA
			2, 3	-55°C, 125°C	4.0		mA
Output Current (source)	IOH	VCC=4.5V, VIH=4.5V, VOUT=VCC-0.4V, VIL=0V	1	25°C		-4.8	mA
			2, 3	-55°C, 125°C		-4.0	mA
Output Voltage Low	VOL	VCC=4.5V, VIH=2.25V IOL=50 μ A, VIL=0.8V	1, 2, 3	25°C		0.1	V
		VCC=5.5V, VIH=2.75V IOL=50 μ A, VIL=0.8V	1, 2, 3	-55°C, 125°C		0.1	V
Output Voltage High	VOH	VCC=4.5V, VIH=2.25V IOH= -50 μ A, VIL=0.8V	1, 2, 3	25°C	VCC-0.1		V
		VCC=5.5V, VIH=2.75V IOH= -50 μ A, VIL=0.8V	1, 2, 3	-55°C, 125°C	VCC-0.1		V
Input Leakage Current	IIN	VCC=5.5V, VIN=VCC or GND	1	25°C		\pm 0.5	μ A
			2, 3	-55°C, 125°C		\pm 5.0	μ A
Noise Immunity Functional Test	FN	VCC=4.5V, VIH=2.25V VIL=0.8V	7, 8A, 8B	25°C, -55°C, 125°C			

AC ELECTRICAL PERFORMANCE CHARACTERISTICS							
PARAMETER	SYMBOL	CONDITIONS	GROUP	TEMPERATURE	LIMITS		UNITS
					MIN	MAX	
Input to YN	TPHL	VCC=4.5V	9	25°C	2	18	ns
			10, 11	125°C, -55°C	2	20	ns
Input to YN	TPLH	VCC=4.5V	9	25°C	2	20	ns
			10, 11	125°C, -55°C	2	22	ns

Notes: RL=500ohms, CL=50pF, TR=TF=3ns

ELECTRICAL PERFORMANCE CHARACTERISTICS						
PARAMETER	SYMBOL	CONDITIONS	TEMPERATURE	LIMITS		UNITS
				MIN	MAX	
Capacitance Power Dissipation	CPD	VCC=5.0V, f=1Mhz	25°C		38	pF
			125°C, -55°C		72	pF
Input Capacitance	CIN	VCC=5.0V, f=1Mhz	25°C		10	pF
			125°C		10	pF
Output Transition Time	TTHL TTLH	VCC=4.5V	25°C		15	ns
			125°C		22	ns

DC POST RADIATION ELECTRICAL CHARACTERISTICS						
PARAMETER	SYMBOL	CONDITION	TEMPERATURE	LIMITS		UNITS
				MIN	MAX	
Quiescent Current	ICC	VCC=5.5V, VIN=VCC or GND	25°C		0.2	mA
Output Current (sink)	IOL	VCC=4.5V, VIH=4.5V VOUT=0.4V, VIL=0V	25°C	4.0		mA
Output Current (source)	IOH	VCC=4.5V, VIH=4.5V, VOUT=VCC-0.4V, VIL=0V	25°C		-4.0	mA
Output Voltage Low	VOL	VCC=4.5V, VIH=2.25V IOL=50uA, VIL=0.8V	25°C		0.1	V
Output Voltage High	VOH	VCC=4.5V, VIH=2.25V IOH= -50uA, VIL=0.8V	25°C	VCC-0.1		V
Input Leakage Current	IIN	VCC=5.5V, VIN=VCC or GND	25°C		± 5	uA
Noise Immunity Functional Test	FN	VCC=4.5V, VIH=2.25V VIL=0.8V	25°C			
Input to Yn	TPHL	VCC=4.5V	25°C	2	20	ns
	TPLH	VCC=4.5V	25°C	2	22	ns

Burn-in and Operating Life Test , Delta Parameters (+25°C)		
PARAMETER	GROUP	DELTA LIMIT
ICC	5	3uA
IOL/IOH	5	-15% of 0 Hour

Radiation Tolerant AAHH00

Dynamic Burn-In Schematic

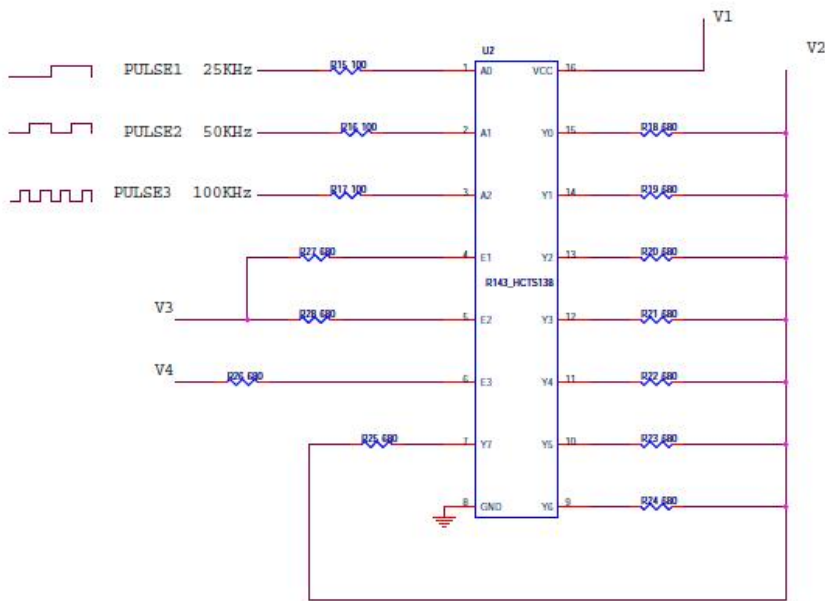

	STATIC	DYNAMIC	TOLERANCES
V1	5.5V	5.5V	5%
V2	OPEN	2.75V	5%
V3	5.5V	0V	5%
V4	0V	5.5V	5%
PULSE1	GND	25KHz/0-5.5V	5%
PULSE2	GND	50KHz/0-5.5V	5%
PULSE3	GND	100KHz/0-5.5V	5%

Total Ionization Dose Schematic

The biasing used for the TID irradiation exposure will be the same as the static burn-in one.

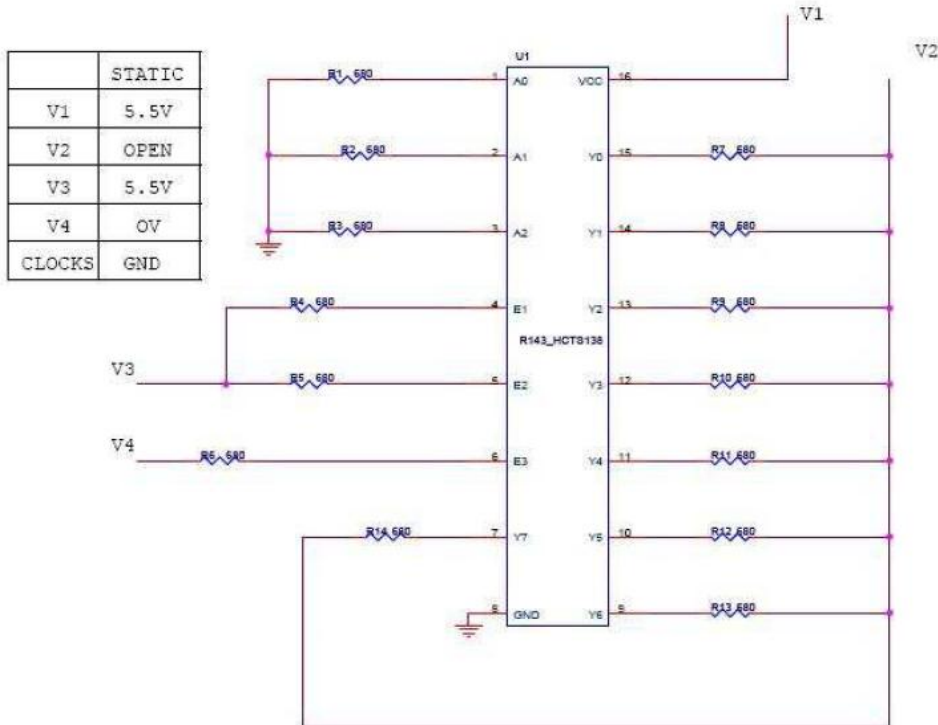

	STATIC
V1	5.5V
V2	OPEN
V3	5.5V
V4	0V
CLOCKS	GND

Radiation Tolerant AAHH00

Timing Diagram

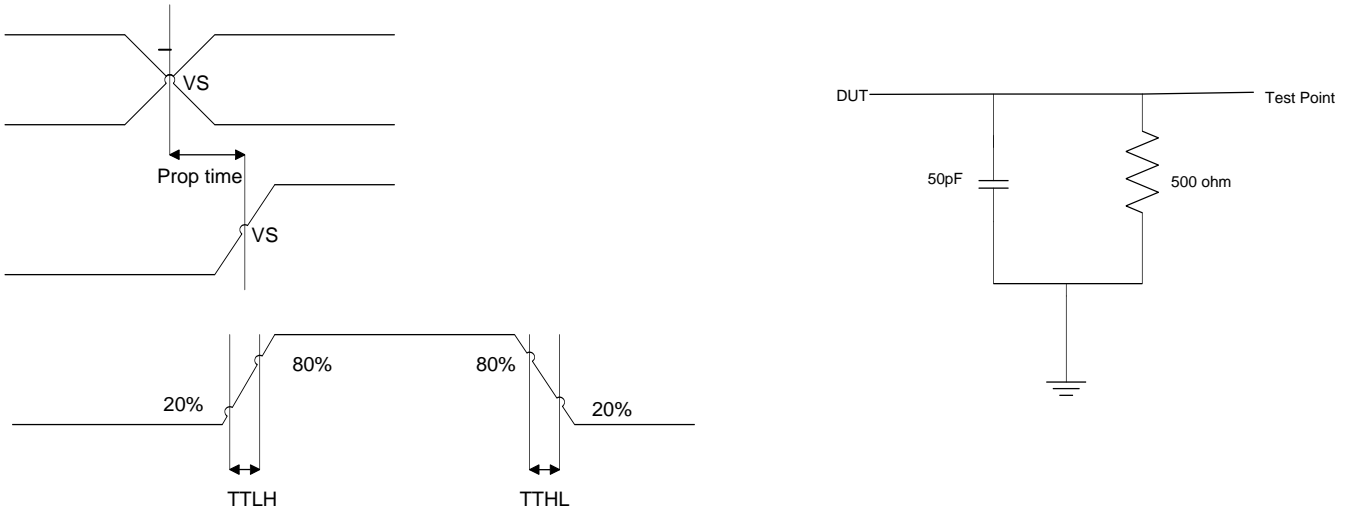

- Note:**
1. Rise/Fall time is 80% to 20%
 2. The propagation time is measured at VS=1.3V

Schematic

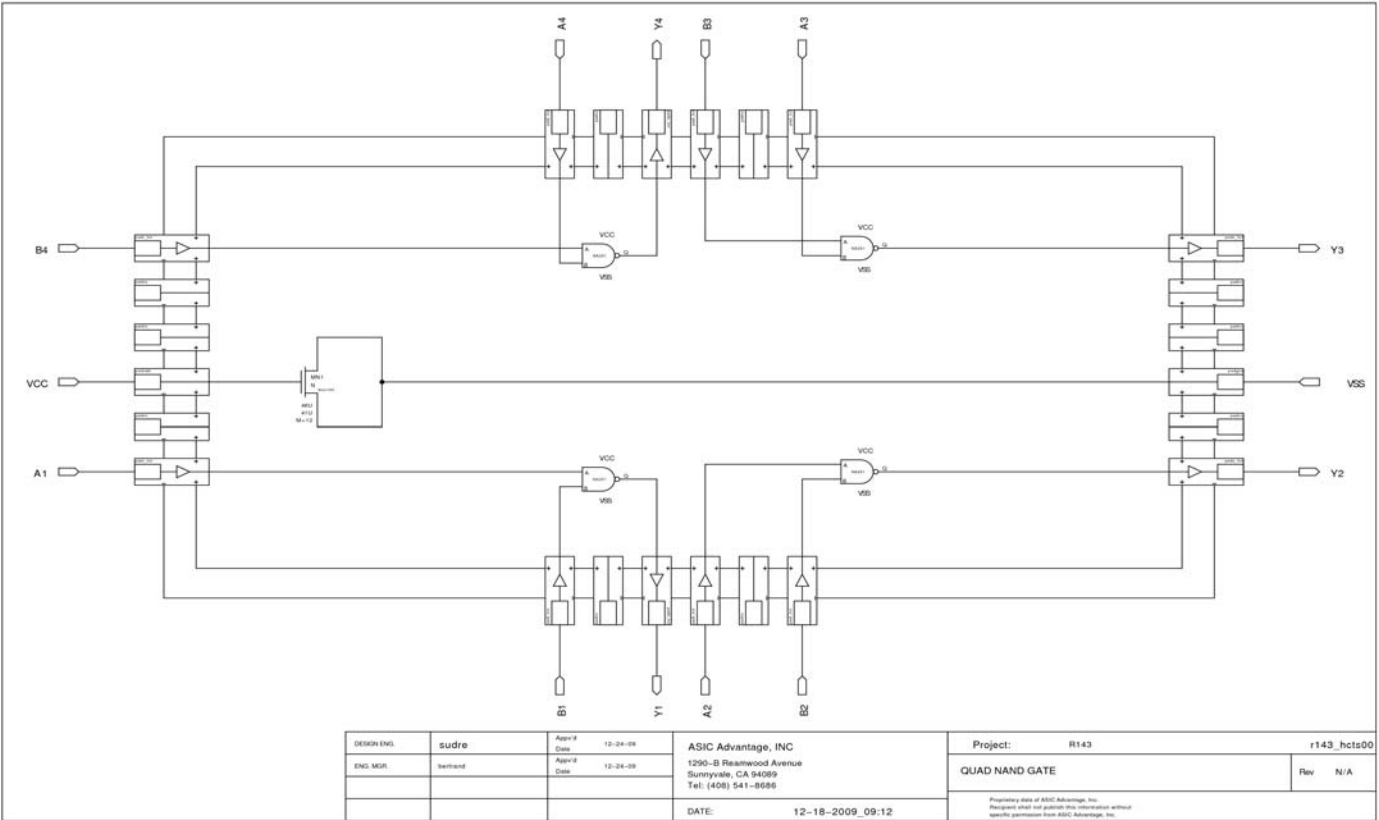

Radiation Tolerant AAHH00

Simulation Waveforms

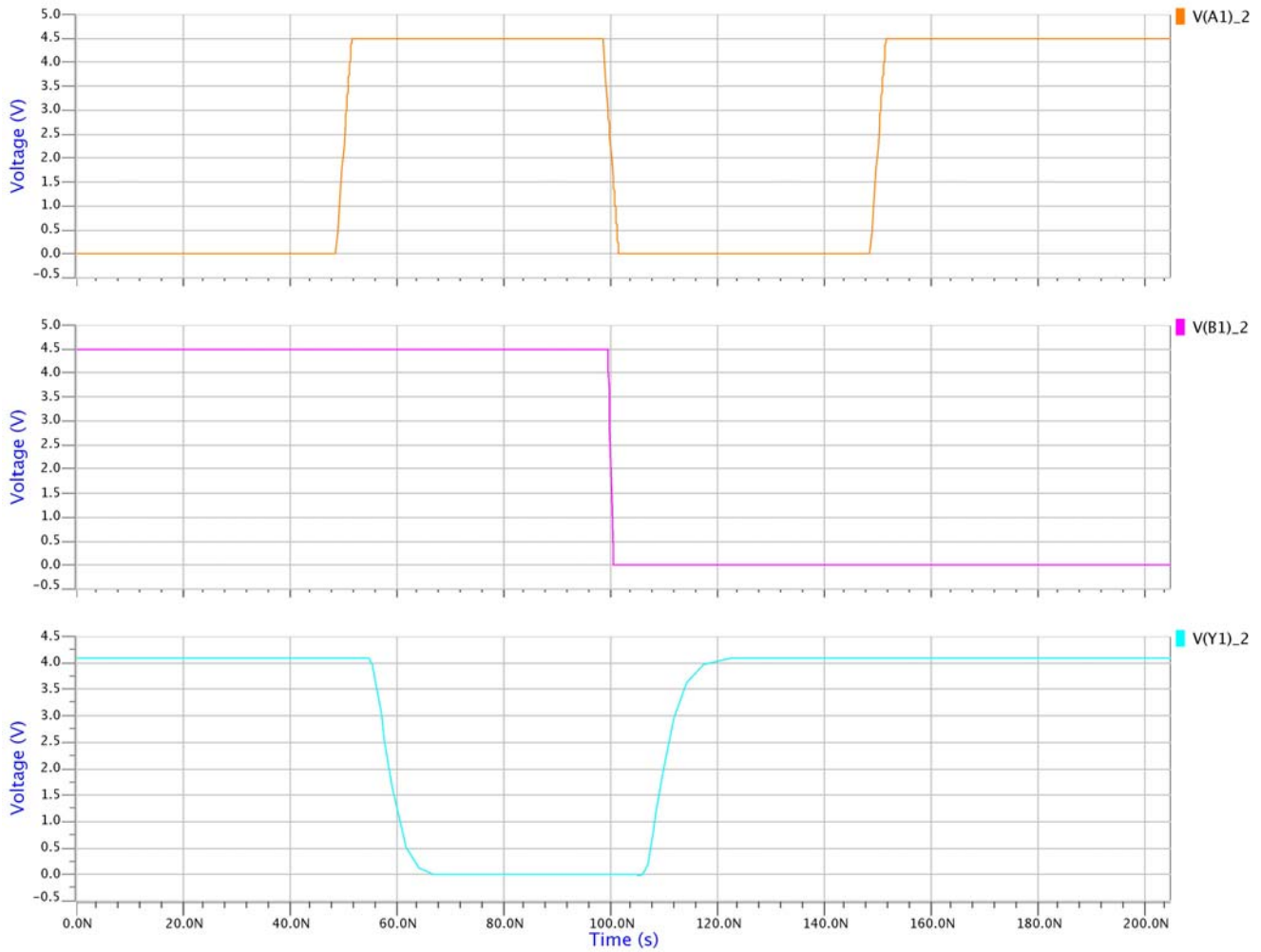

Simulation Readings

			Min	Max		
Input to YN	TPHL	VCC=4.5V	25°C	7.63	14.26	ns
			125°C -55°C	6.25	17.73	ns
Input to YN	TPLH	VCC=4.5V	25°C	5.39	13.37	ns
			125°C -55°C	4.32	17.07	ns

Note: ** Please refer to pads document for DC simulation results

Radiation Tolerant AAHH00

ORDERING INFORMATION

Ordering PN(1)	Subgroup	Description	Temp. Range	Package	Packing Type	Packing Qty
AAHH00 S-L14A	Digital Interface	Quad 2-Input NAND Gate	S - Special -55°C to +125°C	14-Pin Ceramic DFP	TBD	TBD
AAHH00 S-DIE-W-S	Digital Interface	Quad 2-Input NAND Gate	S - Special -55°C to +125°C	Die	Waffle Pack	TBD

- (1) Add "-S" or "-B" to end of part number to specify Class S or Class B screening levels.
Add "-ENGR" for engineering samples, contact factory for more information.
Die is only offered with Class S screening, as indicated.

PACKAGE DIMENSIONS AND MARKING

The AAHH00 devices are available in a 14-Pin Ceramic Dual-In-Line Flatpack package and in Die form. Refer to the latest version of specification AAPS001 (ASIC Advantage's "Package Numbering, Marking, and Outline Standard", available at www.asicadvantage.com, for specific information concerning the package dimensions and package marking.

Radiation Tolerant AAHH00

The following is a brief overview of certain terms and conditions of sale of product. For a full and complete copy of all the General Terms and Conditions of Sale, visit our webpage <http://www.asicadvantage.com/terms.htm>.

LIMITED WARRANTY

The product is warranted that it will conform to the applicable specifications and be free of defects for one year. Buyer is responsible for selection of, use of and results obtained from use of the product. Buyer indemnifies and holds ASIC Advantage, Inc. harmless for claims arising out of the application of ASIC Advantage, Inc.'s products to Buyer's designs. Applications described herein or in any catalogs, advertisements or other documents are for illustrative purposes only.

CRITICAL APPLICATIONS

Products are not authorized for use in critical applications including aerospace and life support applications. Use of products in these applications is fully at the risk of the Buyer. Critical applications include any system or device whose failure to perform can result in significant injury to the user.

LETHAL VOLTAGES

Lethal voltages could be present in the applications. Please comply with all applicable safety regulations.

INTELLECTUAL PROPERTY RIGHTS AND PROPRIETARY DATA

ASIC Advantage, Inc. retains all intellectual property rights in the products. Sale of products does not confer on Buyer any license to the intellectual property. ASIC Advantage, Inc. reserves the right to make changes without notice to the products at any time. Buyer agrees not to use or disclose ASIC Advantage Inc.'s proprietary information without written consent.

TRADEMARKS AND PATENTS

- IN-PLUG® is a registered trademark of ASIC Advantage, Inc.
- AAI's modified snubber network is patented under the US Patent # 6,233,165

PROTECTION FOR CUSTOM SOLUTIONS

When AAI accepts to design and manufacture products to Buyer's designs or specifications, buyer has certain obligations to provide defense in a suit or proceeding claiming infringement of a patent, copyright or trademark or for misappropriation of use of any trade secrets or for unfair competition.

COMPLIANCE WITH LAWS

Buyer agrees that at all times it will comply with all applicable federal, state, municipal, and local laws, orders and regulations. Buyer agrees to comply with all applicable restrictions on exports and re-exports including obtaining any required U.S. Government license, authorization, or approval. Buyer shall pay any duties, levies, taxes, brokerage fees, or customs fees imposed on the products.

TITLE AND DELIVERY

All shipments of goods shall be delivered ExWorks, Sunnyvale, CA, U.S.A. Title in the goods shall not pass to Buyer until ASIC Advantage, Inc. has received in full all amounts owed by Buyer.

LATEST DATASHEET UPDATES

For the latest datasheet updates, visit our web page: <http://www.asicadvantage.com>.

WORLDWIDE REPRESENTATIVES

To access AAI's list of worldwide representatives, visit our web page <http://www.asicadvantage.com>.

COPYRIGHTS

Copyrights and all other proprietary rights in the Content rests with ASIC Advantage Inc. (AAI) or its licensors. All rights in the Content not expressly granted herein are reserved. Except as otherwise provided, the Content published on this document may be reproduced or distributed in unmodified form for personal non-commercial use only. Any other use of the Content, including without limitation distribution, reproduction, modification, display or transmission without the prior written consent of AAI is strictly prohibited. All copyright and other proprietary notices shall be retained on all reproductions.

ASIC Advantage INC.

1290-B Reamwood Ave, Sunnyvale California 94089, USA
Tel: (1) 408-541-8686 Fax: (1) 408-541-8675
Website: <http://www.asicadvantage.com>