

### 3.3V, 5-Bit, 4-Port Bus Switch

#### Product Features:

- Near-zero propagation delay
- Low noise, 25Ω version (PI5B32383)
- 5Ω switches connect inputs to outputs (PI5B3383)
- Direct bus connection when switches are ON
- Ultra-low quiescent power (0.2 μA typical) – Ideally suited for notebook applications
- Packages available:
  - 24-pin 150-mil wide plastic QSOP (Q24)

#### Logic Block Diagram

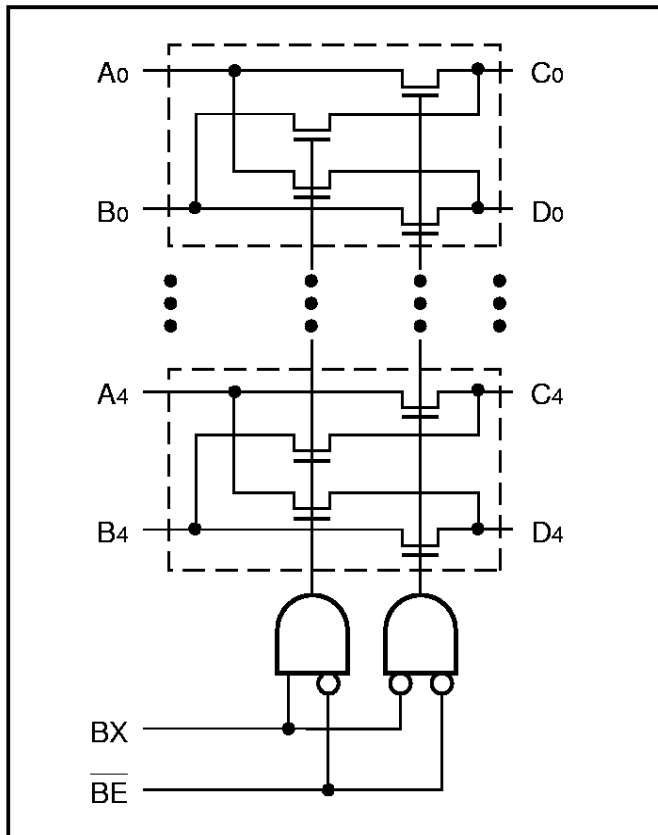

#### Truth Table<sup>(1)</sup>

Function	$\overline{BE}$	BX	A0-A4	B0-B4
Disconnect	H	X	Hi-Z	Hi-Z
Connect	L	L	C0-C4	D0-D4
Exchange	L	H	D0-D4	C0-C4

#### Note:

1. H = High Voltage Level  
X = Don't Care  
L = Low Voltage Level  
Hi-Z = High Impedance

#### Product Description:

Pericom Semiconductor's PI5B series of logic circuits are produced in the Company's advanced 0.35 micron CMOS technology, achieving industry leading performance.

The PI5B3383 and PI5B32383 are 3.3 Volt, 5-bit, 4-port bus switch with exchange designed with a low ON resistance allowing inputs to be connected directly to outputs. The bus switch creates no additional propagational delay or additional ground bounce noise. The switches are turned ON by the Bus Enable ( $\overline{BE}$ ) input signal, and the Bus Exchange (BX) input signal offers nibble swapping of the AB and CD pairs of signals. This exchange configuration allows byte swapping of buses in systems. It can also be used as a quad 2-to-1 multiplexer and to create low delay barrel shifters, etc. The PI5B32383 is designed with an internal 25Ω resistor reducing noise reflection in high-speed applications.

#### Product Pin Configuration

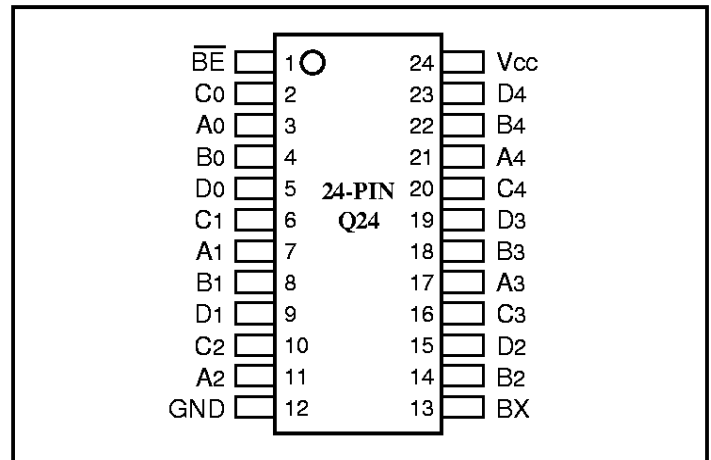

#### Product Pin Description

Pin Name	Description
$\overline{BE}$	Bus Enable Input (Active LOW)
BX	Bus Exchange Input
Ax	Bus A
Bx	Bus B
Cx	Bus C
Dx	Bus D
GND	Ground
Vcc	Power

### Maximum Ratings

(Above which the useful life may be impaired. For user guidelines, not tested.)

Storage Temperature .....	-65°C to +150°C
Ambient Temperature with Power Applied .....	-40°C to +85°C
Supply Voltage to Ground Potential (Inputs & Vcc Only) .....	-0.5V to +4.6V
Supply Voltage to Ground Potential (Outputs & D/O Only) .....	-0.5V to +4.6V
DC Input Voltage .....	-0.5V to +4.6V
DC Output Current .....	120 mA
Power Dissipation .....	0.5W

**Note:**

Stresses greater than those listed under **MAXIMUM RATINGS** may cause permanent damage to the device. This is a stress rating only and functional operation of the device at these or any other conditions above those indicated in the operational sections of this specification is not implied. Exposure to absolute maximum rating conditions for extended periods may affect reliability.

### DC Electrical Characteristics (Over the Operating Range, TA = -40°C to +85°C, VCC = 3.3V ±5%)

Parameters	Description	Test Conditions <sup>(1)</sup>	Min.	Typ <sup>(2)</sup>	Max.	Units	
V <sub>IH</sub>	Input HIGH Voltage	Guaranteed Logic HIGH Level	2.0	—	—	V	
V <sub>IL</sub>	Input LOW Voltage	Guaranteed Logic LOW Level	-0.5	—	0.8	V	
I <sub>IH</sub>	Input HIGH Current	V <sub>CC</sub> = Max., V <sub>IN</sub> = V <sub>CC</sub>	—	—	±1	µA	
I <sub>IL</sub>	Input LOW Current	V <sub>CC</sub> = Max., V <sub>IN</sub> = GND	—	—	±1	µA	
I <sub>OZH</sub>	High Impedance Output Current	0 ≤ AB, CD ≤ V <sub>CC</sub>	—	—	±1	µA	
V <sub>IK</sub>	Clamp Diode Voltage	V <sub>CC</sub> = Min., I <sub>IN</sub> = -18 mA	—	—	-0.8	V	
R <sub>ON</sub>	Switch On Resistance <sup>(4)</sup>	V <sub>CC</sub> = Min., V <sub>IN</sub> = 0.0V, I <sub>ON</sub> = 48 mA or 64 mA	PI5B3383	—	5	7	Ω
			PI5B32383	15	20	40	
		V <sub>CC</sub> = Min., V <sub>IN</sub> = 2.4V, I <sub>ON</sub> = 15 mA	PI5B3383	—	10	15	Ω
		PI5B32383	15	25	48		

### Capacitance (TA = 25°C, f = 1 MHz)

Parameters <sup>(5)</sup>	Description	Test Conditions	Typ	Units
C <sub>IN</sub>	Input Capacitance	V <sub>IN</sub> = 0V	4	pF
C <sub>OFF</sub>	AB/CD Capacitance, Switch Off	V <sub>IN</sub> = 0V	8	pF
C <sub>ON</sub>	AB/CD Capacitance, Switch On	V <sub>IN</sub> = 0V	16	pF

**Notes:**

1. For Max. or Min. conditions, use appropriate value specified under Electrical Characteristics for the applicable device type.
2. Typical values are at V<sub>CC</sub> = 3.3V, TA = 25°C ambient and maximum loading.
3. Not more than one output should be shorted at one time. Duration of the test should not exceed one second.
4. Measured by the voltage drop between AB and CD pin at indicated current through the switch. ON resistance is determined by the lower of the voltages on the two (A or B, C or D) pins.
5. This parameter is determined by device characterization but is not production tested.

### Power Supply Characteristics

Parameters	Description	Test Conditions <sup>(1)</sup>		Min.	Typ <sup>(2)</sup>	Max.	Units
I <sub>cc</sub>	Quiescent Power Supply Current	V <sub>cc</sub> = Max.	V <sub>IN</sub> = GND or V <sub>cc</sub>	—	0.1	3.0	μA
ΔI <sub>cc</sub>	Supply Current per	V <sub>cc</sub> = Max.	V <sub>IN</sub> = 3.0V <sup>(3)</sup>	—	—	750	μA

**Notes:**

1. For Max. or Min. conditions, use appropriate value specified under Electrical Characteristics for the applicable device.
2. Typical values are at V<sub>cc</sub> = 3.3V, +25°C ambient.
3. Per TTL driven input (V<sub>IN</sub> = 3.0V, control inputs only); A, B, C, and D pins do not contribute to I<sub>cc</sub>.
4. This current applies to the control inputs only and represent the current required to switch internal capacitance at the specified frequency. The A, B, C, and D inputs generate no significant AC or DC currents as they transition. This parameter is not tested, but is guaranteed by design.

### PI5B3383 Switching Characteristics over Operating Range

Parameters	Description	Conditions <sup>(2,3)</sup>	PI5B3383			Unit
			Com			
			Min	Typ	Max	
t <sub>PLH</sub> t <sub>PHL</sub>	Propagation Delay <sup>(2,3)</sup> Ax to Cx, Bx to Dx	C <sub>L</sub> = 50 pF, R <sub>L</sub> = 500Ω	—	0.25	—	ns
t <sub>EZH</sub> t <sub>EZL</sub>	Bus Enable Time BE to Cx or Dx	C <sub>L</sub> = 20 pF, R <sub>L</sub> = 500Ω	1	—	2	
		C <sub>L</sub> = 50 pF, R <sub>L</sub> = 500Ω	1	—	4	
t <sub>PHZ</sub> t <sub>PLZ</sub>	Bus Disable Time BE to Cx or Dx	C <sub>L</sub> = 20 pF, R <sub>L</sub> = 500Ω	1	—	2	
		C <sub>L</sub> = 50 pF, R <sub>L</sub> = 500Ω	1	—	5	
t <sub>BX</sub>	Bus Exchange Time Bx to Cx or Dx	C <sub>L</sub> = 20 pF, R <sub>L</sub> = 500Ω	1	—	2	
		C <sub>L</sub> = 50 pF, R <sub>L</sub> = 500Ω	1	—	4	

**Notes:**

1. See test circuit and wave forms.
2. This parameter is guaranteed but not tested on Propagation Delays.
3. The bus switch contributes no propagational delay other than the RC delay of the ON resistance of the switch and the load capacitance. The time constant for the switch alone is of the order of 0.25 ns for 50 pF load. Since this time constant is much smaller than the rise/fall times of typical driving signals, it adds very little propagational delay to the system. Propagational delay of the bus switch when used in a system is determined by the driving circuit on the driving side of the switch and its interaction with the load on the driven side.

**PI5B32383 Switching Characteristics over Operating Range**

Parameters	Description	Conditions <sup>(2,3)</sup>	PI5B32383			Unit
			Com			
			Min	Typ	Max	
$t_{PLH}$ $t_{PHL}$	Propagation Delay <sup>(2,3)</sup> Ax to Cx, Bx to Dx	$C_L = 50 \text{ pF}, R_L = 500\Omega$	–	1.25	–	ns
$t_{PZH}$ $t_{PZL}$	Bus Enable Time $\overline{BE}$ to Cx or Dx	$C_L = 20 \text{ pF}, R_L = 500\Omega$	1	–	2	
		$C_L = 50 \text{ pF}, R_L = 500\Omega$	1	–	4	
$t_{PHZ}$ $t_{PLZ}$	Bus Disable Time $\overline{BE}$ to Cx or Dx	$C_L = 20 \text{ pF}, R_L = 500\Omega$	1	–	2	
		$C_L = 50 \text{ pF}, R_L = 500\Omega$	1	–	5	
$t_{BX}$	Bus Exchange Time Bx to Cx or Dx	$C_L = 20 \text{ pF}, R_L = 500\Omega$	1	–	2	
		$C_L = 50 \text{ pF}, R_L = 500\Omega$	1	–	4	

**Notes:**

1. See test circuit and wave forms.
2. This parameter is guaranteed but not tested on Propagation Delays.
3. The bus switch contributes no propagational delay other than the RC delay of the ON resistance of the switch and the load capacitance. The time constant for the switch alone is of the order of 0.25 ns for 50 pF load. Since this time constant is much smaller than the rise/fall times of typical driving signals, it adds very little propagational delay to the system. Propagational delay of the bus switch when used in a system is determined by the driving circuit on the driving side of the switch and its interaction with the load on the driven side.