

SN74ALS874B, SN74ALS876A, SN74AS874, SN74AS876
SN54ALS874B, SN54AS874
DUAL 4-BIT D-TYPE EDGE-TRIGGERED FLIP-FLOPS

D2661, APRIL 1982 - REVISED MAY 1986

- 3-State Buffer-Type Outputs Drive Bus-Lines Directly
- Bus-Structured Pinout
- Choice of True or Inverting Logic
 'ALS874B, 'AS874 True Outputs
 'ALS876A, 'AS876 Inverting Outputs
- Asynchronous Clear
- Package Options Include Plastic "Small Outline" Packages, Ceramic Chip Carriers, and Standard Plastic and Ceramic 300-mil DIPs
- Dependable Texas Instruments Quality and Reliability

SN54ALS874B, SN54AS874 . . . JT PACKAGE
SN74ALS874B, SN74AS874 . . . DW OR NT PACKAGE

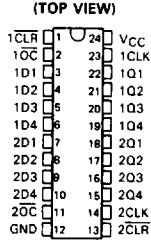

description

These dual four-bit registers feature three-state outputs designed specifically for bus driving. This makes these devices particularly suitable for implementing buffer registers, I/O ports, bidirectional bus drivers, and working registers.

The edge-triggered flip-flops enter data on the low-to-high transition of the clock. The 'ALS874B and 'AS874 have $\overline{\text{CLR}}$ inputs and noninverting Q outputs; the 'ALS876A and 'AS876 have $\overline{\text{PRE}}$ inputs and inverting Q outputs. In each case, taking this input low causes the four Q or Q outputs to go low independently of the clock.

The SN54ALS' and SN54AS' devices are characterized for operation over the full military temperature range of -55°C to 125°C . The SN74ALS' and SN74AS' devices are characterized for operation from 0°C to 70°C .

SN54ALS874B, SN54AS874 . . . FK PACKAGE
 (TOP VIEW)

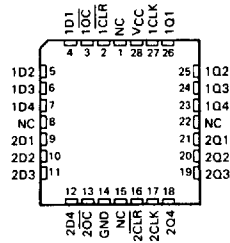

SN74ALS876A, SN74AS876 . . . DW OR NT PACKAGE
 (TOP VIEW)

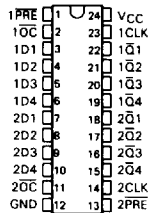

SN74ALS874B, SN74ALS876A, SN74AS874, SN74AS876
SN54ALS874B, SN54AS874
DUAL 4-BIT D-TYPE EDGE-TRIGGERED FLIP-FLOPS

FUNCTION TABLES

'ALS874B, 'AS874 (EACH FLIP-FLOP)

INPUTS				OUTPUT
\overline{OC}	CLR	CLK	D	Q
L	L	X	X	L
L	H	↑	H	H
L	H	↑	L	L
L	H	L	X	Q_0
H	X	X	X	Z

'ALS876A, 'AS876 (EACH FLIP-FLOP)

INPUTS				OUTPUT
\overline{OC}	PRE	CLK	D	\overline{Q}
L	L	X	X	L
L	H	↑	H	L
L	H	↑	L	H
L	H	L	X	\overline{Q}_0
H	X	X	X	Z

logic symbols†

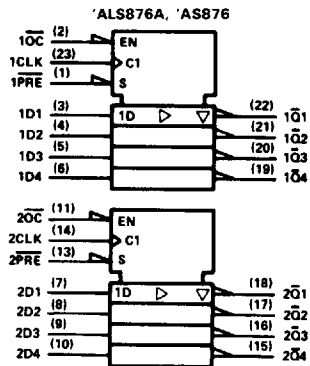
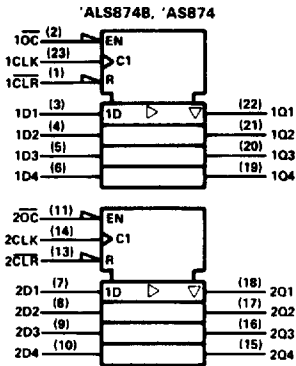

†These symbols are in accordance with ANSI/IEEE Std 91-1984 and IEC Publication 617 12

logic diagrams (positive logic)

'ALS874B, 'AS874 (EACH QUAD FLIP-FLOP)

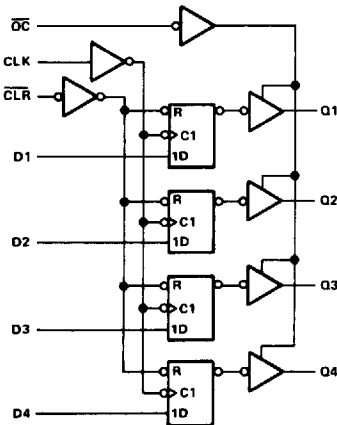

'ALS876A, 'AS876 (EACH QUAD FLIP-FLOP)

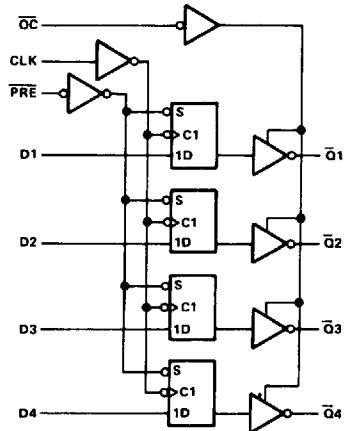

Pin numbers shown are for DW, JT, and NT packages



SN74ALS874B, SN74ALS876A
SN54ALS874B
DUAL 4-BIT D-TYPE EDGE-TRIGGERED FLIP-FLOPS

absolute maximum ratings over operating free-air temperature range (unless otherwise noted)

Supply voltage, V_{CC}	7 V
Input voltage	7 V
Voltage applied to a disabled 3-state output	5.5 V
Operating free-air temperature range: SN54ALS874B	-55°C to 125°C
SN74ALS874B, SN74ALS876A	0°C to 70°C
Storage temperature range	-65°C to 150°C

recommended operating conditions

		SN54ALS874B			SN74ALS874B SN74ALS876A			UNIT		
		MIN	NOM	MAX	MIN	NOM	MAX			
V_{CC}	Supply voltage	4.5	5	5.5	4.5	5	5.5	V		
V_{IH}	High-level input voltage	2			2			V		
V_{IL}	Low-level input voltage	0.7			0.8			V		
I_{OH}	High-level output current	-1			-2.6			mA		
I_{OL}	Low-level output current	12			24			mA		
f_{clock}	Clock frequency	0			30			MHz		
t_w	Pulse duration	PRE or CLR low		10		10		ns		
		CLK high		20		16.5				
		CLK low		20		16.5				
t_{su}	Setup time before CLK \dagger	Data		15		15		ns		
		PRE or CLR inactive		10		10				
t_h	Hold time, data after CLK \dagger	4			0			ns		
T_A	Operating free-air temperature	-55			125			0	70	°C

electrical characteristics over recommended operating free-air temperature range (unless otherwise noted)

PARAMETER	TEST CONDITIONS	SN54ALS874B			SN74ALS874B SN74ALS876A			UNIT
		MIN	TYP \dagger	MAX	MIN	TYP \dagger	MAX	
V_{IK}	$V_{CC} = 4.5$ V, $I_I = -18$ mA	-1.2			1.2			V
V_{OH}	$V_{CC} = 4.5$ V to 5.5 V, $I_{OH} = -0.4$ mA	$V_{CC} - 2$			$V_{CC} - 2$			V
	$V_{CC} = 4.5$ V, $I_{OH} = -1$ mA	2.4			3.3			
	$V_{CC} = 4.5$ V, $I_{OH} = -2.6$ mA				2.4			
V_{OL}	$V_{CC} = 4.5$ V, $I_{OL} = 12$ mA	0.25			0.4			V
	$V_{CC} = 4.5$ V, $I_{OL} = 24$ mA				0.35			
I_{OZH}	$V_{CC} = 5.5$ V, $V_O = 2.7$ V	20			20			μ A
I_{OZL}	$V_{CC} = 5.5$ V, $V_O = 0.4$ V	-20			20			μ A
I_I	$V_{CC} = 5.5$ V, $V_I = 7$ V	0.1			0.1			mA
I_{IH}	$V_{CC} = 5.5$ V, $V_I = 2.7$ V	20			20			μ A
I_{IL}	$V_{CC} = 5.5$ V, $V_I = 0.4$ V	-0.2			-0.2			mA
I_O^{\ddagger}	$V_{CC} = 5.5$ V, $V_O = 2.25$ V	-30			-112			mA
I_{CC}	$V_{CC} = 5.5$ V		Output high	14	21	14	21	mA
			Outputs low	19	30	19	30	
			Outputs disabled	20	32	20	32	
			Outputs high			14	21	
			Outputs low			18	29	
			Outputs disabled			20	31	

\dagger All typical values are at $V_{CC} = 5$ V, $T_A = 25^\circ$ C

\ddagger The output conditions have been chosen to produce a current that closely approximates one half of the true short-circuit output current, I_{OS}



SN74ALS874B, SN74ALS876A
SN54ALS874B
DUAL 4-BIT D-TYPE EDGE-TRIGGERED FLIP-FLOPS

'ALS874B switching characteristics (see Note 1)

PARAMETER	FROM (INPUT)	TO (OUTPUT)	V _{CC} = 5 V, C _L = 50 pF, R ₁ = 500 Ω, R ₂ = 500 Ω, T _A = 25°C			V _{CC} = 4.5 V to 5.5 V, C _L = 50 pF, R ₁ = 500 Ω, R ₂ = 500 Ω, T _A = MIN to MAX			UNIT	
			'ALS874B			SN64ALS874B		SN74ALS874B		
			MIN	TYP	MAX	MIN	MAX	MIN		MAX
f _{max}			40	50	25		30		MHz	
t _{PLH}	CLK	Any Q		8	10	4	15	4	14	ns
t _{PHL}				8	13	4	15	4	14	
t _{PHL}	CL _R	Any Q		11	14	5	20	5	17	ns
t _{PZH}	OC	Any Q		9	12	4	21	4	18	ns
t _{PZL}				11	15	4	21	4	18	
t _{PHZ}	OC	Any Q		6	8	2	12	2	10	ns
t _{PLZ}				5	7	8	3	15	3	

'ALS876A switching characteristics (see Note 1)

PARAMETER	FROM (INPUT)	TO (OUTPUT)	V _{CC} = 5 V, C _L = 50 pF, R ₁ = 500 Ω, R ₂ = 500 Ω, T _A = 25°C			V _{CC} = 4.5 V to 5.5 V, C _L = 50 pF, R ₁ = 500 Ω, R ₂ = 500 Ω, T _A = MIN to MAX			UNIT
			'ALS876A			SN74ALS876A			
			MIN	TYP	MAX	MIN	MAX		
f _{max}			40	50		30		MHz	
t _{PLH}	CLK	Any Q		8	11	4	14		ns
t _{PHL}				9	12	4	14		
t _{PHL}	PRE	Any Q		10	16	6	19		ns
t _{PZH}	OC	Any Q		10	13	4	18		ns
t _{PZL}				11	15	4	18		
t _{PHZ}	OC	Any Q		6	8	2	10		ns
t _{PLZ}				7	10	3	13		

NOTE 1: Load circuit and voltage waveforms are shown in Section 1.

SN74AS874, SN74AS876, SN54AS874 DUAL 4-BIT D-TYPE EDGE-TRIGGERED FLIP-FLOPS

absolute maximum ratings over operating free-air temperature range (unless otherwise noted)

Supply voltage, V_{CC}	7 V
Input voltage	7 V
Operating free-air temperature range: SN54AS874	-55°C to 125°C
SN74AS874, SN74AS876	0°C to 70°C
Storage temperature range	-65°C to 150°C

recommended operating conditions

		SN54AS874			SN74AS874 SN74AS876			UNIT
		MIN	NOM	MAX	MIN	NOM	MAX	
V_{CC}	Supply voltage	4.5	5	5.5	4.5	5	5.5	V
V_{IH}	High-level input voltage	2			2			V
V_{IL}	Low-level input voltage			0.8			0.8	V
I_{OH}	High-level output current			-12			-15	mA
I_{OL}	Low-level output current			32			48	mA
f_{clock}	Clock frequency	0		100	0		125	MHz
t_w	Pulse duration	PRE or CLR low		4		2		ns
		CLK high		4		3		
		CLK low		5		4		
t_{su}	Setup time before CLK↑	Data		2.5		2		ns
		PRE or CLR inactive		5		4		
t_h	Hold time, data after CLK↑		1		1			ns
T_A	Operating free-air temperature	-55		125	0		70	°C

electrical characteristics over recommended operating free-air temperature range (unless otherwise noted)

PARAMETER	TEST CONDITIONS	SN54AS874			SN74AS874 SN74AS876			UNIT
		MIN	TYP†	MAX	MIN	TYP†	MAX	
V_{IK}	$V_{CC} = 4.5\text{ V}$, $I_I = -18\text{ mA}$			-1.2			-1.2	V
V_{OH}	$V_{CC} = 4.5\text{ V to }5.5\text{ V}$, $I_{OH} = -2\text{ mA}$	$V_{CC} - 2$			$V_{CC} - 2$			V
	$V_{CC} = 4.5\text{ V}$, $I_{OH} = -12\text{ mA}$	2.4	3.2					
	$V_{CC} = 4.5\text{ V}$, $I_{OH} = -15\text{ mA}$				2.4	3.3		
V_{OL}	$V_{CC} = 4.5\text{ V}$, $I_{OL} = 32\text{ mA}$		0.25	0.4				V
	$V_{CC} = 4.5\text{ V}$, $I_{OL} = 48\text{ mA}$				0.35	0.5		
I_{OZH}	$V_{CC} = 5.5\text{ V}$, $V_O = 2.7\text{ V}$			50			50	μA
I_{OZL}	$V_{CC} = 5.5\text{ V}$, $V_O = 0.4\text{ V}$			-50			-50	μA
I_I	$V_{CC} = 5.5\text{ V}$, $V_I = 7\text{ V}$			0.1			0.1	mA
I_{IH}	$V_{CC} = 5.5\text{ V}$, $V_I = 2.7\text{ V}$			20			10	μA
I_{IL}	D			-3			-2	mA
	All other			-0.5			-0.5	
I_O^\ddagger	$V_{CC} = 5.5\text{ V}$, $V_O = 2.25\text{ V}$	-30		-112	-30		-112	mA
I_{CC}	'AS874	$V_{CC} = 5.5\text{ V}$	Output high	82	133	82	133	mA
			Outputs low	92	149	92	149	
			Outputs disabled	100	160	100	160	
			Outputs high			88	142	
			Outputs low			94	150	
			Outputs disabled			100	160	
'AS876	$V_{CC} = 5.5\text{ V}$	Output high					mA	
		Outputs low						
		Outputs disabled						
		Outputs high						
		Outputs low						
		Outputs disabled						

† All typical values are at $V_{CC} = 5\text{ V}$, $T_A = 25^\circ\text{C}$

‡ The output conditions have been chosen to produce a current that closely approximates one half of the true short circuit output current I_{OS}

SN74AS874, SN74AS876, SN54AS874
DUAL 4-BIT D-TYPE EDGE-TRIGGERED FLIP-FLOPS

'AS874 switching characteristics (see Note 1)

PARAMETER	FROM (INPUT)	TO (OUTPUT)	$V_{CC} = 4.5 \text{ V to } 5.5 \text{ V,}$ $C_L = 50 \text{ pF,}$ $R_1 = 500 \Omega,$ $R_2 = 500 \Omega,$ $T_A = \text{MIN to MAX}$				UNIT
			SN54AS874		SN74AS874		
			MIN	MAX	MIN	MAX	
f_{max}			100		125		MHz
t_{PLH}	CLK	Any Q	3	11.5	3	8.5	ns
t_{PHL}			4	12.5	4	10.5	
t_{PHL}	CLR	Any Q	4	11	4	9.5	ns
t_{PZH}	\overline{OC}	Any Q	2	8	2	7	ns
t_{PZL}			3	11.5	3	10.5	
t_{PHZ}	\overline{OC}	Any Q	2	7	2	6	ns
t_{PLZ}			2	8.5	2	7.5	

'AS876 switching characteristics (see Note 1)

PARAMETER	FROM (INPUT)	TO (OUTPUT)	$V_{CC} = 4.5 \text{ V to } 5.5 \text{ V,}$ $C_L = 50 \text{ pF,}$ $R_1 = 500 \Omega,$ $R_2 = 500 \Omega,$ $T_A = \text{MIN to MAX}$		UNIT
			SN74AS876		
			MIN	MAX	
f_{max}			125		MHz
t_{PLH}	CLK	Any \overline{Q}	3	8.5	ns
t_{PHL}			4	10.5	
t_{PHL}	PRE	Any \overline{Q}	4	9.5	ns
t_{PZH}	\overline{OC}	Any \overline{Q}	2	7	ns
t_{PZL}			3	10.5	
t_{PHZ}	\overline{OC}	Any \overline{Q}	2	6	ns
t_{PLZ}			2	6	

NOTE 1: Load circuit and voltage waveforms are shown in Section 1.