



PI74AVC16271
PI74AVCH16271

12-Bit To 24-Bit Multiplexed Bus Exchanger
with 3-State Outputs

Product Features

- Designed for low voltage operation, V_{CC} from 1.65V to 3.6V
- Sub 2.0ns delays at 2.5V and 3.3V
- Dynamic Impedance Control on outputs, current drive $> \pm 24\text{mA}$ at 2.5V V_{CC}
- Patented noise reduction circuit
- I/O Tolerant to 3.6V, Inputs and Outputs for mixed voltage systems
- Supports live insertion
- Industrial operation at -40°C to $+85^{\circ}\text{C}$
- Available Packages:
 - 48-pin 240 mil wide plastic TSSOP (A48)
 - 48-pin 173 mil wide plastic TVSOP (K48)

Product Description

Pericom Semiconductor’s PI74AVC series of logic circuits are produced using the Company’s advanced 0.35 micron CMOS technology, achieving industry leading speed.

The 12-bit to 24-bit multiplexed bus exchanger is designed for applications in which two separate data paths must be multiplexed onto, or demultiplexed from, a single data path. This device is particularly suitable as an interface between conventional DRAMs and high-speed microprocessors

Data is stored in the internal A-to-B registers on the low-to-high transition of the clock (CLK) input, provided clock-enable (CLKENA) inputs are low. Proper control of these inputs allows two sequential 12-bit words to be presented as a 24-bit word on the B port.

To maximize memory access throughput, transparent latches in the B-to-A path allow asynchronous operation. These latches transfer data when the latch-enable (\overline{LE}) inputs are low. The select (SEL) line selects 1B or 2B data for the A outputs. Data flow is controlled by the active-low output enables (\overline{OEA} , \overline{OEB}).

To ensure the high-impedance state during power up or power down, \overline{OE} should be tied to V_{CC} through a pullup resistor, the minimum value of the resistor is determined by the current-sinking capability of the driver.

The PI74AVCH16271 has “Bus Hold” which retains the data input’s last state whenever the data input goes to high-impedance preventing “floating” inputs and eliminating the need for pullup/down resistors.

Logic Block Diagram

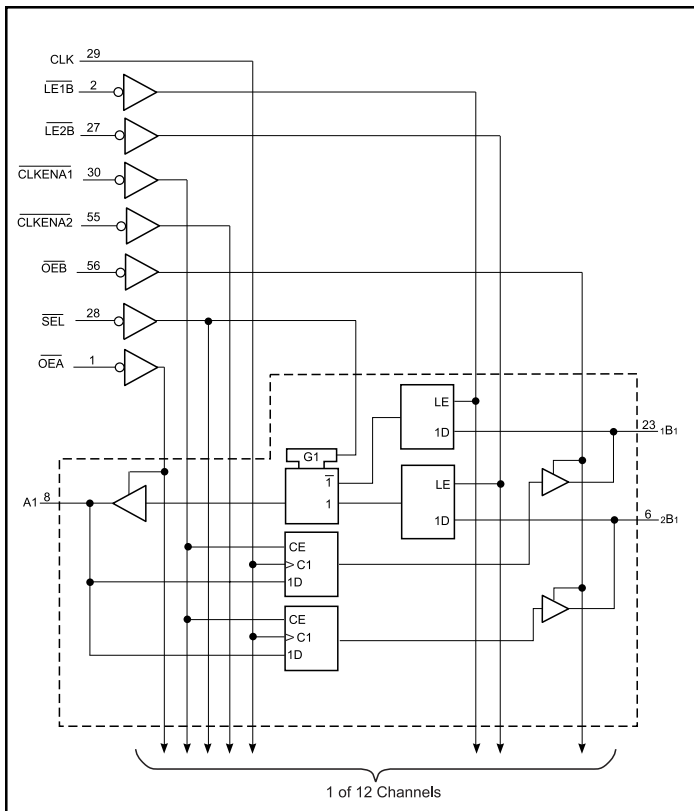

Product Pin Description

Pin Name	Description
\overline{OE}	Output Enable Input (Active LOW)
CLK	Clock
\overline{SEL}	Select (Active Low)
\overline{CLKEN}	Clock Enable (Active Low)
A,1B,2B	3-State Outputs
GND	Ground
Vcc	Power

Product Pin Configuration

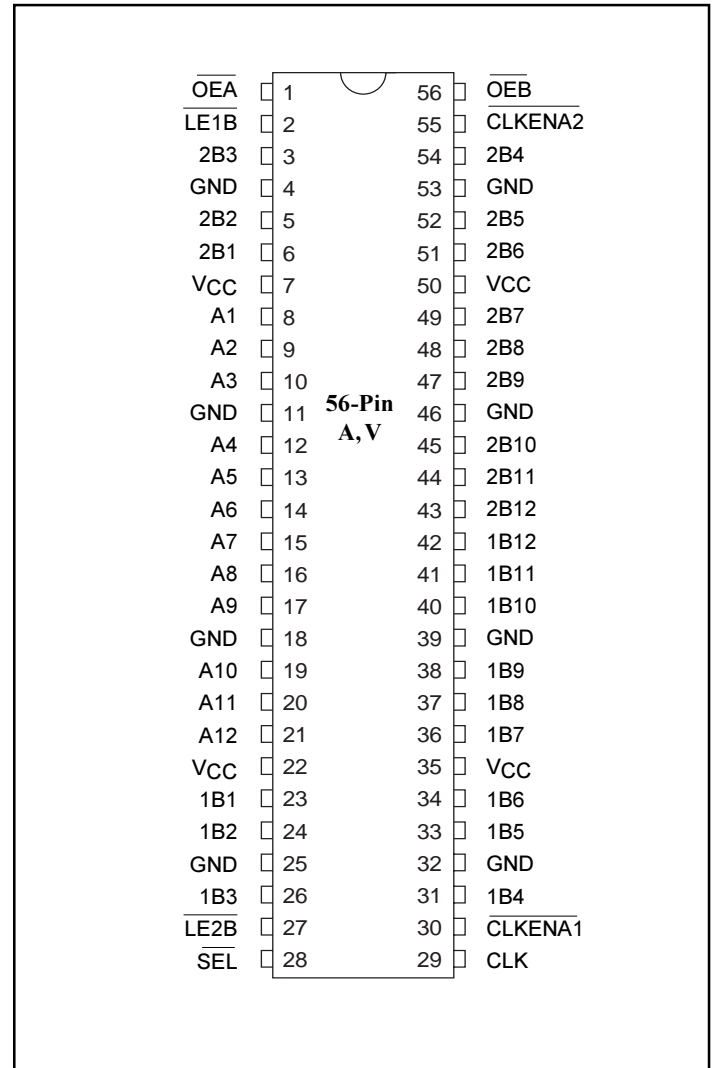

Truth Tables⁽¹⁾

Output Enable

INPUTS		OUTPUTS	
\overline{OEA}	\overline{OEB}	A	1B,2B
H	H	Z	Z
H	L	Z	Active
L	H	Active	Z
L	L	Active	Active

A to B STORAGE ($\overline{OEB} = L$)

INPUTS			OUTPUTS		
$\overline{CLKENA1}$	$\overline{CLKENA2}$	CLK	A	1B	2B
H	H	X	X	1B0 ⁽²⁾	2B0 ⁽²⁾
L	X	↑	L	L	X
L	X	↑	H	H	X
X	L	↑	L	X	L
X	L	↑	H	A ₀	H

B to A STORAGE ($\overline{OEA} = L$)

INPUTS				Outputs A
\overline{LE}	\overline{SEL}	1B	2B	
H	X	X	X	A ₀ ⁽²⁾
H	X	X	X	A ₀ ⁽²⁾
L	H	L	X	L
L	H	H	X	H
L	L	X	L	L
L	L	X	H	H

Notes:

- H = High Signal Level, L = Low Signal Level
X = Irrelevant, Z = High Impedance
↑ = Transition, Low to High
- Output level before the indicated steady state input conditions were established.



Maximum Ratings

(Above which the useful life may be impaired. For user guidelines, not tested.)

Storage Temperature	-65°C to +150°C
Supply Voltage Range, V _{CC}	-0.5V to 4.6V
Input Voltage Range, V _I :	
Except I/O ports (See Note 1):	-0.5V to 4.6V
I/O ports (See Notes 1 and 2)	-0.5V to V _{CC} + 0.5V
Output Voltage Range, V _O (See Notes 1 and 2) ..	-0.5V to V _{CC} + 0.5V
Input Clamp current, I _{IK} (V _I < 0)	-50mA
Output Clamp current, I _{OK} (V _O < 0 or V _O > V _{CC})	±50mA
Continuous Output Current, I _O (V _O = 0 to V _{CC})	±50mA
Continuous Current through each V _{CC} or GND	±100mA
Maximum Power Dissipation:	
A package	1W
V package	1.4W

Note:

Stresses greater than those listed under MAXIMUM RATINGS may cause permanent damage to the device. This is a stress rating only and functional operation of the device at these or any other conditions above those indicated in the operational sections of this specification is not implied. Exposure to absolute maximum rating conditions for extended periods may affect reliability.

Notes:

1. The input and output negative-voltage ratings may be exceeded if the input and output clamp-current ratings are observed.
2. This value is limited to 4.6V maximum.

DC Electrical Characteristics (Over the Operating Range, T_A = -40°C to +85°C, V_{CC} = 3.3V ± 10%)

Parameters	Description	Test Conditions ⁽³⁾	Min.	Typ.	Max.	Units
V _{CC}	Supply Voltage		2.3		3.6	V
V _{IH}	Input HIGH Voltage	V _{CC} = 2.3V to 2.7V	1.7			
		V _{CC} = 2.7V to 3.6V	2.0			
V _{IL}	Input LOW Voltage	V _{CC} = 2.3V to 2.7V			0.7	
		V _{CC} = 2.7V to 3.6V			0.8	
V _{IN}	Input Voltage		0		V _{CC}	
V _{OUT}	Output Voltage		0		V _{CC}	
I _{OH}	HIGH-level Output Current	V _{CC} = 2.3V			-12	mA
		V _{CC} = 2.7V			-12	
		V _{CC} = 3.0V			-24	
I _{OL}	LOW-level Output Current	V _{CC} = 2.3V			12	
		V _{CC} = 2.7V			12	
		V _{CC} = 3.0V			24	

Note:

3. Unused control inputs must be held HIGH or LOW to prevent them from floating.



DC Electrical Characteristics-Continued (Over the Operating Range, $T_A = -40^{\circ}\text{C}$ to $+85^{\circ}\text{C}$, $V_{CC} = 3.3\text{V} \pm 10\%$)

Parameters	Test Conditions	$V_{CC}^{(1)}$	Min.	Typ. ⁽²⁾	Max.	Units
V_{OH}	$I_{OH} = -100\mu\text{A}$	Min. to Max.	$V_{CC} - 0.2$			V
	$I_{OH} = -6\text{mA}$	$V_{IH} = 1.7\text{V}$	2.3V	2.0		
	$I_{OH} = -12\text{mA}$	$V_{IH} = 1.7\text{V}$	2.3V	1.7		
		$V_{IH} = 2.0\text{V}$	2.7V	2.2		
		$V_{IH} = 2.0\text{V}$	3.0V	2.4		
$I_{OH} = -24\text{mA}$	$V_{IH} = 2.0\text{V}$	3.0V	2.0			
V_{OL}	$I_{OL} = 100\mu\text{A}$	Min. to Max.			0.2	V
	$I_{OL} = 6\text{mA}$	$V_{IL} = 0.7\text{V}$	2.3V		0.4	
	$I_{OL} = 12\text{mA}$	$V_{IL} = 0.7\text{V}$	2.3V		0.7	
		$V_{IL} = 0.8\text{V}$	2.7V		0.4	
	$I_{OL} = 24\text{mA}$	$V_{IL} = 0.8\text{V}$	3.0V		0.55	
I_I	$V_I = V_{CC}$ or GND		3.6V		± 5	μA
I_I (Hold)	$V_I = 0.7\text{V}$	2.3V	45			
	$V_I = 1.7\text{V}$		-45			
	$V_I = 0.8\text{V}$	3.0V	75			
	$V_I = 2.0\text{V}$		-75			
		$V_I = 0$ to $3.6\text{V}^{(3)}$	3.6V			± 500
$I_{OZ}^{(4)}$	$V_O = V_{CC}$ or GND		3.6V		± 10	
I_{CC}	$V_I = V_{CC}$ or GND, $I_O = 0$		3.6V		40	
ΔI_{CC}	One input at $V_{CC} - 0.6\text{V}$, Other inputs at V_{CC} or GND		3V to 3.6V		750	
C_I Control Inputs	$V_I = V_{CC}$ or GND		3.3V		3.5	pF
C_{IO} A or B Ports	$V_O = V_{CC}$ or GND		3.3V		9	

Notes:

1. For Max. or Min. conditions, use appropriate value specified under Electrical Characteristics for the applicable device type.
2. Typical values are at $V_{CC} = 3.3\text{V}$, $+25^{\circ}\text{C}$ ambient and maximum loading.
3. Bus hold maximum dynamic current required to switch the input from one state to another
4. For I/O ports, the I_{OZ} includes the input leakage current.

Timing Requirements over Operating Range

Parameters	Description		V _{CC} = 2.5 V ± 0.2 V		V _{CC} = 2.7 V		V _{CC} = 3.3 V ± 0.3 V		Units
			Min.	Max.	Min.	Max.	Min.	Max.	
f _{CLOCK}	Clock frequency		0	130	0	130	0	130	Mhz
t _w	Pulse duration, CLK high or Low		3.3		3.3		3.3		ns
t _{SU}	Setup time	A before CLK↑	2.6		2.1		1.7		
		B before \overline{LE}	1.7		1.5		1.3		
		\overline{CLKEN} before CLK↑	1.6		1.3		1.0		
t _H	Hold time	A after CLK↑	0.6		0.6		0.7		
		B after \overline{LE}	0.9		0.9		1.1		
		\overline{CLKEN} after CLK↑	1.0		0.9		0.9		
Δt/Δv ⁽¹⁾	Input Transition Rise or Fall		0	10	0	10	0	10	ns/V

Notes:

1. Unused control inputs must be held HIGH or LOW to prevent them from floating.

Switching Characteristics over Operating Range⁽¹⁾

Parameters	From (INPUT)	To (OUTPUT)	V _{CC} = 2.5V ± 0.2V		V _{CC} = 2.7V		V _{CC} = 3.3V ± 0.3V		Units
			Min. ⁽²⁾	Max.	Min. ⁽²⁾	Max.	Min. ⁽²⁾	Max. ⁽²⁾	
f _{MAX}			130		130		130		MHz
t _{PD}	CLK	B	1.0	6.2		5.0	1.0	4.3	ns
t _{PD}	B	A	1.0	5.3		4.7	1.4	4.0	
t _{PD}	\overline{LE}	A	1.0	6.0		5.9	1.4	4.8	
t _{PD}	\overline{SEL}	A	1.1	6.4		6.2	1.3	5.2	
t _{EN}	\overline{OEB} or \overline{OEA}	B or A	1.0	6.0		6.1	1.0	5.1	
t _{DIS}	\overline{OEB} or \overline{OEA}	B or A	1.4	5.4		4.6	1.7	4.2	

Notes:

1. Unused control inputs must be held HIGH or LOW to prevent them from floating.
2. Minimum limits are guaranteed but not tested on Propagation Delays.



Operating Characteristics, $T_A = 25^\circ\text{C}$

Parameter		Test Conditions	$V_{CC} = 2.5\text{V} \pm 0.2\text{V}$	$V_{CC} = 3.3\text{V} \pm 0.3\text{V}$	Units
			Typical	Typical	
C _{pd} Power Dissipation Capacitance	A to B	Outputs Enabled	92	105	pF
		Outputs Disabled	61	76	
	B to A	Outputs Enabled	39	43	
		Outputs Disabled	11	13	