

REVISIONS

LTR	DESCRIPTION	DATE (YR-MO-DA)	APPROVED
E	Remove vendor CAGE 18324. Correction on vendor CAGE 01295 part notation. Convert to Military Drawing format. Editorial changes throughout. Add LCC package. Remove vendor CAGE 27014.	87-06-19	N. A. Hauck
F	Add MIL-M-38510/ number for LCC package. Add QPL inactive label to front page. Change code ident. no. from 14933 to 67268. Editorial changes throughout.	87-08-11	N. A. Hauck
G	Changes in accordance with NOR 5962-R179-92. --tvn	92-04-29	Monica L. Poelking
H	Update to reflect latest changes in format and requirements. Editorial changes throughout. --les	03-01-30	Raymond Monnin
J	Correct marking paragraph. Editorial changes throughout. gap	05-12-07	Raymond Monnin
K	Update drawing to current MIL-PRF-38535 requirements. - jt	17-10-20	Charles Saffle

Current CAGE code is 67268

The original first sheet of this drawing has been replaced.



REV																				
SHEET																				
REV																				
SHEET																				
REV STATUS	REV	K	K	K	K	K	K	K	K	K	K	K								
OF SHEETS	SHEET	1	2	3	4	5	6	7	8	9	10									
PMIC N/A	PREPARED BY Joe A. Kerby	<p align="center">DLA LAND AND MARITIME COLUMBUS, OHIO 43218-3990 http://www.dla.mil/landandmaritime</p> <p>MICROCIRCUIT, DIGITAL, LOW-POWER SCHOTTKY TTL, FLIP-FLOP, MONOLITHIC SILICON</p>																		
<p align="center">STANDARD MICROCIRCUIT DRAWING</p> <p>THIS DRAWING IS AVAILABLE FOR USE BY ALL DEPARTMENTS AND AGENCIES OF THE DEPARTMENT OF DEFENSE</p>	CHECKED BY D. A. DiCenzo																			
	APPROVED BY N.A. Hauck																			
	DRAWING APPROVAL DATE 76-03-23																			
AMSC N/A	REVISION LEVEL K	SIZE A	CAGE CODE 14933	76013																
		SHEET		1 OF 10																

1. SCOPE

1.1 Scope. This drawing describes device requirements for MIL-STD-883 compliant, non-JAN class level B microcircuits in accordance with MIL-PRF-38535, appendix A.

1.2 Part or Identifying Number (PIN). The complete PIN is as shown in the following example:

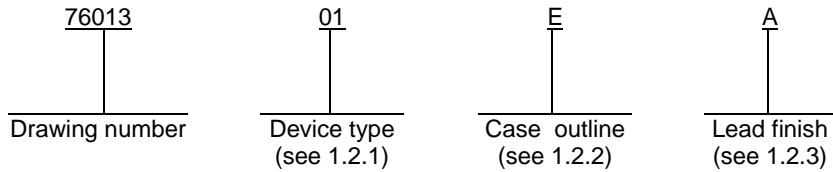

1.2.1 Device type. The device type identify the circuit function as follows:

<u>Device type</u>	<u>Generic number</u>	<u>Circuit function</u>
01	54LS76	Dual J-K negative edge-triggered flip-flop

1.2.2 Case outlines. The case outlines are as designated in MIL-STD-1835 and as follows:

<u>Outline letter</u>	<u>Descriptive designator</u>	<u>Terminals</u>	<u>Package style</u>
E	GDIP1-T16 or CDIP2-T16	16	dual-in-line
F	GDFP2-F16 or CDFP3-F16	16	flat
2	CQCC1-N20	20	square chip carrier

1.2.3 Lead finish. The lead finish is as specified in MIL-PRF-38535, appendix A.

1.3 Absolute maximum ratings.

Supply voltage	-0.5 V dc to +7.0 V dc
Input voltage range	-1.5 V dc at -18 mA to +5.5 V dc
Storage temperature range	-65°C to +150°C
Maximum power dissipation (P _D) 1/	22 mW
Lead temperature (soldering, 10 seconds)	+300°C
Thermal resistance, junction-to-case (θ _{JC})	See MIL-STD-1835
Junction temperature (T _J)	+175°C

1.4 Recommended operating conditions.

Supply voltage range (V _{CC})	4.5 V dc minimum to 5.5 V dc maximum
Minimum high level input voltage (V _{IH})	2.0 V dc
Maximum low level input voltage (V _{IL})	0.7 V dc
Case operating temperature range (T _C)	-55°C to +125°C

1/ Maximum power dissipation is defined as V_{CC} x I_{CC}. Must withstand the added P_D due to short circuit test (e.g. Ios).

STANDARD MICROCIRCUIT DRAWING DLA LAND AND MARITIME COLUMBUS, OHIO 43218-3990	SIZE A	76013
	REVISION LEVEL K	SHEET 2

2. APPLICABLE DOCUMENTS

2.1 Government specification, standards, and handbooks. The following specification, standards, and handbooks form a part of this drawing to the extent specified herein. Unless otherwise specified, the issues of these documents are those cited in the solicitation or contract.

DEPARTMENT OF DEFENSE SPECIFICATION

MIL-PRF-38535 - Integrated Circuits, Manufacturing, General Specification for.

DEPARTMENT OF DEFENSE STANDARDS

MIL-STD-883 - Test Method Standard Microcircuits.
MIL-STD-1835 - Interface Standard Electronic Component Case Outlines.

DEPARTMENT OF DEFENSE HANDBOOKS

MIL-HDBK-103 - List of Standard Microcircuit Drawings.
MIL-HDBK-780 - Standard Microcircuit Drawings.

(Copies of these documents are available online at <http://quicksearch.dla.mil/> or from the Standardization Document Order Desk, 700 Robbins Avenue, Building 4D, Philadelphia, PA 19111-5094.)

2.2 Order of precedence. In the event of a conflict between the text of this drawing and the references cited herein, the text of this drawing takes precedence. Nothing in this document, however, supersedes applicable laws and regulations unless a specific exemption has been obtained.

3. REQUIREMENTS

3.1 Item requirements. The individual item requirements shall be in accordance with MIL-PRF-38535, appendix A for non-JAN class level B devices and as specified herein. Product built to this drawing that is produced by a Qualified Manufacturer Listing (QML) certified and qualified manufacturer or a manufacturer who has been granted transitional certification to MIL-PRF-38535 may be processed as QML product in accordance with the manufacturers approved program plan and qualifying activity approval in accordance with MIL-PRF-38535. This QML flow as documented in the Quality Management (QM) plan may make modifications to the requirements herein. These modifications shall not affect form, fit, or function of the device. These modifications shall not affect the PIN as described herein. A "Q" or "QML" certification mark in accordance with MIL-PRF-38535 is required to identify when the QML flow option is used.

3.2 Design, construction, and physical dimensions. The design, construction, and physical dimensions shall be as specified in MIL-PRF-38535, appendix A and herein.

3.2.1 Case outlines. The case outlines shall be in accordance with 1.2.2 herein.

3.2.2 Terminal connections. The terminal connections shall be as specified on figure 1.

3.2.3 Truth table. The truth table shall be as specified on figure 2.

3.2.4 Logic diagrams. The logic diagrams shall be as specified on figure 3.

3.3 Electrical performance characteristics. Unless otherwise specified herein, the electrical performance characteristics are as specified in table I and shall apply over the full case operating temperature range.

STANDARD MICROCIRCUIT DRAWING	SIZE A		76013
		REVISION LEVEL K	SHEET 3

DLA LAND AND MARITIME
COLUMBUS, OHIO 43218-3990

TABLE I. Electrical performance characteristics.

Test	Symbol	Conditions -55°C ≤ T _C ≤ +125°C unless otherwise specified		Group A subgroups	Device type	Limits		Unit
						Min	Max	
High level output voltage	V _{OH}	V _{CC} = 4.5 V, I _{OH} = -400 μA V _{IL} = 0.7 V, V _{IH} = 2.0 V		1, 2, 3	01	2.5		V
Low level output voltage	V _{OL}	V _{CC} = 4.5 V, I _{OL} = 4 mA V _{IL} = 0.7 V, V _{IH} = 2.0 V		1, 2, 3	01		0.4	V
Input clamp voltage	V _{IC}	V _{CC} = 4.5 V, I _{IN} = -18 mA, T _C = +25°C		1	01		-1.5	V
High level input current at J or K	I _{IH1}	V _{CC} = 5.5 V, V _{IN} = 2.7 V		1, 2, 3	01		20	μA
High level input current at clock	I _{IH2}			1, 2, 3	01		80	μA
High level input current at preset or clear	I _{IH3}			1, 2, 3	01		60	μA
High level input current at J or K	I _{IH4}	V _{CC} = 5.5 V, V _{IN} = 5.5 V		1, 2, 3	01		100	μA
High level input current at clock	I _{IH5}			1, 2, 3	01		400	μA
High level input current at preset or clear	I _{IH6}			1, 2, 3	01		300	μA
Low level input current at J or K	I _{IL1}	V _{CC} = 5.5 V, V _{IN} = 0.4 V		1, 2, 3	01		-400	μA
Low level input current at clock, preset, or clear	I _{IL2}			1, 2, 3	01		-800	μA
Short circuit output current	I _{OS}	V _{CC} = 5.5 V, V _{OUT} = 0.0 V <u>1/</u>		1, 2, 3	01	-6	-130	mA
Supply current	I _{CC}	V _{CC} = 5.5 V		1, 2, 3	01		8	mA
Functional tests		See 4.3.1c		7				
Maximum clock frequency	F _{MAX}	V _{CC} = 5.0 V, R _L = 2 kΩ ±5% <u>2/</u>	C _L = 15 pF ±10%	9	01	25		MHz
				10, 11	01	18		MHz
				9	01	20		MHz
				10, 11	01	15		MHz

See footnotes at end of table.

**STANDARD
MICROCIRCUIT DRAWING**

DLA LAND AND MARITIME
COLUMBUS, OHIO 43218-3990

SIZE
A

76013

REVISION LEVEL
K

SHEET
4

TABLE I. Electrical performance characteristics - Continued.

Test	Symbol	Conditions -55°C ≤ T _c ≤ +125°C unless otherwise specified		Group A subgroups	Device type	Limits		Unit
						Min	Max	
Propagation delay time, high to low level, clock, clear, or preset to Q or \bar{Q}	t _{PHL}	V _{CC} = 5.0 V, R _L = 2 kΩ ±5% 2/	C _L = 15 pF ±10%	9	01		30	ns
				10, 11	01		42	ns
			C _L = 50 pF ±10%	9	01		35	ns
				10, 11	01		49	ns
Propagation delay time, low to high level, clock, clear, or preset to Q or \bar{Q}	t _{PLH}		C _L = 15 pF ±10%	9	01		20	ns
				10, 11	01		28	ns
			C _L = 50 pF ±10%	9	01		25	ns
				10, 11	01		35	ns

1/ Not more than one output should be shorted at a time, and the duration of the short-circuit condition should not exceed one second.

2/ Propagation delay time testing and maximum clock frequency testing may be performed using either C_L = 15 pF or C_L = 50 pF. However, the manufacturer must certify and guarantee that the microcircuits meet the switching test limits specified for a 50 pF load.

3.4 Electrical test requirements. The electrical test requirements shall be the subgroups specified in table II. The electrical tests for each subgroup are described in table I.

3.5 Marking. Marking shall be in accordance with MIL-PRF-38535, appendix A. The part shall be marked with the PIN listed in 1.2 herein. In addition, the manufacturer's PIN may also be marked.

3.5.1 Certification/compliance mark. A compliance indicator "C" shall be marked on all non-JAN devices built in compliance to MIL-PRF-38535, appendix A. The compliance indicator "C" shall be replaced with a "Q" or "QML" certification mark in accordance with MIL-PRF-38535 to identify when the QML flow option is used.

3.6 Certificate of compliance. A certificate of compliance shall be required from a manufacturer in order to be listed as an approved source of supply in MIL-HDBK-103 (see 6.6 herein). The certificate of compliance submitted to DLA Land and Maritime -VA prior to listing as an approved source of supply shall affirm that the manufacturer's product meets the requirements of MIL-PRF-38535, appendix A and the requirements herein.

3.7 Certificate of conformance. A certificate of conformance as required in MIL-PRF-38535, appendix A shall be provided with each lot of microcircuits delivered to this drawing.

3.8 Notification of change. Notification of change to DLA Land and Maritime -VA shall be required for any change that affects this drawing.

3.9 Verification and review. DLA Land and Maritime, DLA Land and Maritime's agent, and the acquiring activity retain the option to review the manufacturer's facility and applicable required documentation. Offshore documentation shall be made available onshore at the option of the reviewer.

**STANDARD
MICROCIRCUIT DRAWING**

DLA LAND AND MARITIME
COLUMBUS, OHIO 43218-3990

SIZE
A

76013

REVISION LEVEL
K

SHEET
5

Case outlines	E, F	2
Terminal number	Terminal symbols	Terminal symbols
1	1 CLK	N/C
2	1 $\overline{\text{PRE}}$	1 CLK
3	1 CLR	1 $\overline{\text{PRE}}$
4	1 J	1 CLR
5	V _{CC}	1 J
6	2 CLK	N/C
7	2 $\overline{\text{PRE}}$	V _{CC}
8	2 CLR	2 CLK
9	2 J	2 $\overline{\text{PRE}}$
10	2 $\overline{\text{Q}}$	2 CLR
11	2 Q	N/C
12	2 K	2 J
13	GND	2 $\overline{\text{Q}}$
14	1 $\overline{\text{Q}}$	2 Q
15	1 Q	2 K
16	1 K	N/C
17	---	GND
18	---	1 $\overline{\text{Q}}$
19	---	1 Q
20	---	1 K

FIGURE 1. Terminal connections.

**STANDARD
MICROCIRCUIT DRAWING**

DLA LAND AND MARITIME
COLUMBUS, OHIO 43218-3990

SIZE
A

76013

REVISION LEVEL
K

SHEET
6

Inputs					Outputs	
$\overline{\text{PRE}}$	$\overline{\text{CLR}}$	CLK	J	K	Q	$\overline{\text{Q}}$
L	H	X	X	X	H	L
H	L	X	X	X	L	H
L	L	X	X	X	H*	H*
H	H	↓	L	L	Q ₀	$\overline{\text{Q}}_0$
H	H	↓	H	L	H	L
H	H	↓	L	H	L	H
H	H	↓	H	H	TOGGLE	
H	H	H	X	X	Q ₀	$\overline{\text{Q}}_0$

H = High level (steady state).

L = Low level (steady state).

X = Irrelevant.

↓ = Transition from high to low level.

Q₀ = The level of Q before the indicated steady state input conditions were established.

Toggle: Each output changes to the complement of its previous level on each ↓ clock transition.

* This configuration is nonstable, that is, it will not persist when preset and clear inputs return to their inactive (high) level.

FIGURE 2. Truth table.

**STANDARD
MICROCIRCUIT DRAWING**

DLA LAND AND MARITIME
COLUMBUS, OHIO 43218-3990

SIZE
A

76013

REVISION LEVEL
K

SHEET
7

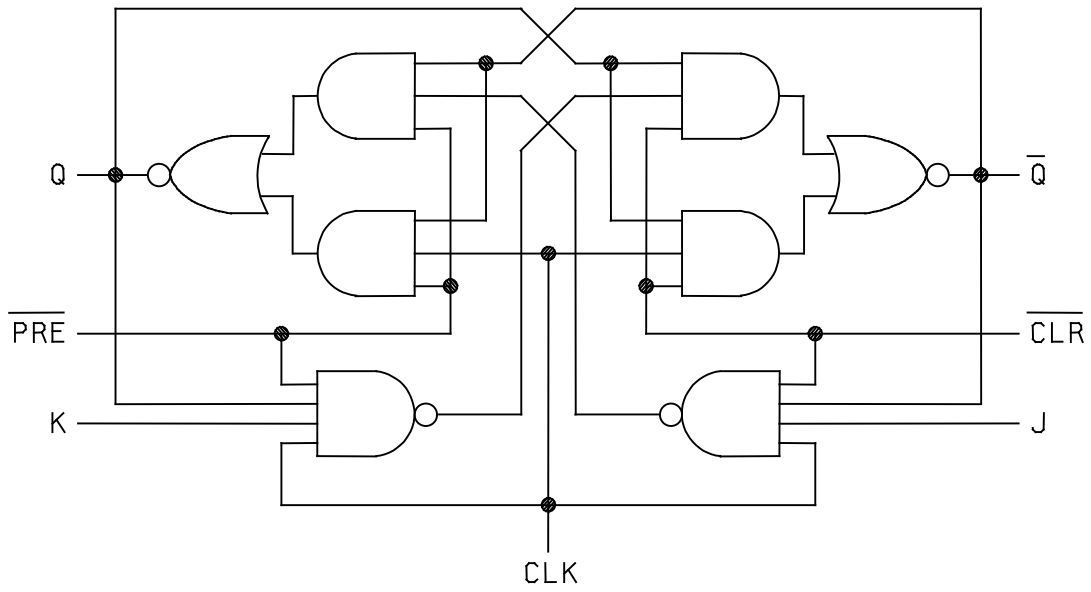

FIGURE 3. Logic diagram.

**STANDARD
MICROCIRCUIT DRAWING**

DLA LAND AND MARITIME
COLUMBUS, OHIO 43218-3990

SIZE
A

76013

REVISION LEVEL
K

SHEET
8

4. VERIFICATION

4.1 Sampling and inspection. Sampling and inspection procedures shall be in accordance with MIL-PRF-38535, appendix A.

4.2 Screening. Screening shall be in accordance with method 5004 of MIL-STD-883, and shall be conducted on all devices prior to quality conformance inspection. The following additional criteria shall apply:

a. Burn-in test, method 1015 of MIL-STD-883.

(1) Test condition A, B, C or D. The test circuit shall be maintained by the manufacturer under document revision level control and shall be made available to the preparing or acquiring activity upon request. The test circuit shall specify the inputs, outputs, biases, and power dissipation, as applicable, in accordance with the intent specified in method 1015 of MIL-STD-883.

(2) T_A = +125°C, minimum.

b. Interim and final electrical test parameters shall be as specified in table II herein, except interim electrical parameter tests prior to burn-in are optional at the discretion of the manufacturer.

4.3 Quality conformance inspection. Quality conformance inspection shall be in accordance with method 5005 of MIL-STD-883 including groups A, B, C, and D inspections. The following additional criteria shall apply.

4.3.1 Group A inspection.

a. Tests shall be as specified in table II herein.

b. Subgroups 4, 5, 6, and 8 in table I, method 5005 of MIL-STD-883 shall be omitted.

c. Subgroup 7 shall include verification of the truth table.

TABLE II. Electrical test requirements.

MIL-STD-883 test requirements	Subgroups (in accordance with MIL-STD-883, method 5005, table I)
Interim electrical parameters (method 5004)	- - -
Final electrical test parameters (method 5004)	1*, 2, 3, 9
Group A test requirements (method 5005)	1, 2, 3, 7, 9, 10**, 11**
Groups C and D end-point electrical parameters (method 5005)	1, 2, 3

* PDA applies to subgroup 1.

** Subgroups 10 and 11, if not tested, shall be guaranteed to the specified limits in table I.

STANDARD MICROCIRCUIT DRAWING DLA LAND AND MARITIME COLUMBUS, OHIO 43218-3990	SIZE A		76013
		REVISION LEVEL K	SHEET 9

4.3.2 Groups C and D inspections.

- a. End-point electrical parameters shall be as specified in table II herein.
- b. Steady-state life test conditions, method 1005 of MIL-STD-883.
 - (1) Test condition A, B, C or D. The test circuit shall be maintained by the manufacturer under document revision level control and shall be made available to the preparing or acquiring activity upon request. The test circuit shall specify the inputs, outputs, biases, and power dissipation, as applicable, in accordance with the intent specified in method 1005 of MIL-STD-883.
 - (2) $T_A = +125^{\circ}\text{C}$, minimum.
 - (3) Test duration: 1,000 hours, except as permitted by method 1005 of MIL-STD-883.

5. PACKAGING

5.1 Packaging requirements. The requirements for packaging shall be in accordance with MIL-PRF-38535, appendix A.

6. NOTES

6.1 Intended use. Microcircuits conforming to this drawing are intended for use for Government microcircuit applications (original equipment), design applications, and logistics purposes.

6.2 Replaceability. Microcircuits covered by this drawing will replace the same generic device covered by a contractor-prepared specification or drawing.

6.3 Configuration control of SMD's. All proposed changes to existing SMD's will be coordinated with the users of record for the individual documents. This coordination will be accomplished using DD Form 1692, Engineering Change Proposal.

6.4 Record of users. Military and industrial users shall inform DLA Land and Maritime when a system application requires configuration control and the applicable SMD to that system. DLA Land and Maritime will maintain a record of users and this list will be used for coordination and distribution of changes to the drawings. Users of drawings covering microelectronics devices (FSC 5962) should contact DLA Land and Maritime -VA, telephone (614) 692-8108.

6.5 Comments. Comments on this drawing should be directed to DLA Land and Maritime -VA, Columbus, Ohio 43218-3990, or telephone (614) 692-0540.

6.6 Approved sources of supply. Approved sources of supply are listed in MIL-HDBK-103 and QML-38535. The vendors listed in MIL-HDBK-103 and QML-38535 have agreed to this drawing and a certificate of compliance (see 3.6 herein) has been submitted to and accepted by DLA Land and Maritime -VA.

**STANDARD
MICROCIRCUIT DRAWING**
DLA LAND AND MARITIME
COLUMBUS, OHIO 43218-3990

SIZE
A

76013

REVISION LEVEL
K

SHEET
10

STANDARD MICROCIRCUIT DRAWING BULLETIN

DATE: 17-10-20

Approved sources of supply for SMD 76013 are listed below for immediate acquisition information only and shall be added to MIL-HDBK-103 and QML-38535 during the next revision. MIL-HDBK-103 and QML-38535 will be revised to include the addition or deletion of sources. The vendors listed below have agreed to this drawing and a certificate of compliance has been submitted to and accepted by DLA Land and Maritime -VA. This information bulletin is superseded by the next dated revision of MIL-HDBK-103 and QML-38535. DLA Land and Maritime maintains an online database of all current sources of supply at <https://landandmaritimeapps.dla.mil/Programs/Smcr/>.

Standard microcircuit drawing PIN <u>1/</u>	Vendor CAGE number	Vendor similar PIN <u>2/</u>	Reference military specification PIN
7601301EA	01295	SNJ54LS76AJ	M38510/301102BEA
	<u>3/</u>	54LS76A/BEAJC	
7601301FA	01295	SNJ54LS76AW	M38510/30110BFA
	<u>3/</u>	54LS76A/BFAJC	
76013012A	01295	SNJ54LS76AFK	M38510/30110B2A
	<u>3/</u>	54LS76AM/B2AJC	

- 1/ The lead finish shown for each PIN representing a hermetic package is the most readily available from the manufacturer listed for that part. If the desired lead finish is not listed contact the vendor to determine its availability.
- 2/ Caution. Do not use this number for item acquisition. Items acquired to this number may not satisfy the performance requirements of this drawing.
- 3/ Not available from an approved source of supply.

Vendor CAGE number

01295

Vendor name and address

Texas Instruments, Inc.
Semiconductor Group
8505 Forest Ln.
PO Box 660199
Dallas, TX 75243

The information contained herein is disseminated for convenience only and the Government assumes no liability whatsoever for any inaccuracies in the information bulletin.