

QuickSwitch® Products 3.3V 8-Bit Bus Switch for Hot Swap Applications (HotSwitch™)

**QS3VH245
 QS3VH2245**

FEATURES/BENEFITS

- N channel FET switches with no parasitic diode to V_{CC}
 - No DC path to V_{CC} or GND
 - 5V tolerant in OFF state
- Low R_{ON} - 4 Ω typical
- Flat R_{ON} characteristics from 0 – 5V
- Bidirectional dataflow with near-zero delay
 - No added ground bounce
- Excellent R_{ON} matching between channels
- Low capacitance
- Maximum operating frequency for data – 150MHz
- LVTTTL-compatible control inputs
- Undershoot clamp diodes on all control and switch inputs
- QS3VH245 is 25 Ω version for low noise and line matching
- QS3VH245 available in QSOP, SOIC and TSSOP packages
- QS3VH2245 available in QSOP and SOIC packages

DESCRIPTION

The QS3VH245 and QS3VH2245 HotSwitch 8-bit bus switches are specially designed for hot-swapping environment. The QS3VH245 has very low ON resistance resulting in under 200ps propagation delay through the switch. The QS3VH2245 with 25 Ω ON resistance with 1.25ns propagation delay is ideal for line matching and low noise environments. The switches can be turned ON under the control of an LVTTTL-compatible Output Enable signal for bidirectional data flow with no added delay or ground-bounce. In the OFF state, the switches are 5V-tolerant and offer very high impedance at the terminals.

The combination of near-zero propagation delay, high OFF impedance, and over-voltage tolerance makes QS3VH245 and QS3VH2245 ideal for hot swapping applications. The low ON resistance of QS3VH245 makes it ideal for PCI and CompactPCI hot swapping environment.

Figure 1. Functional Block Diagram

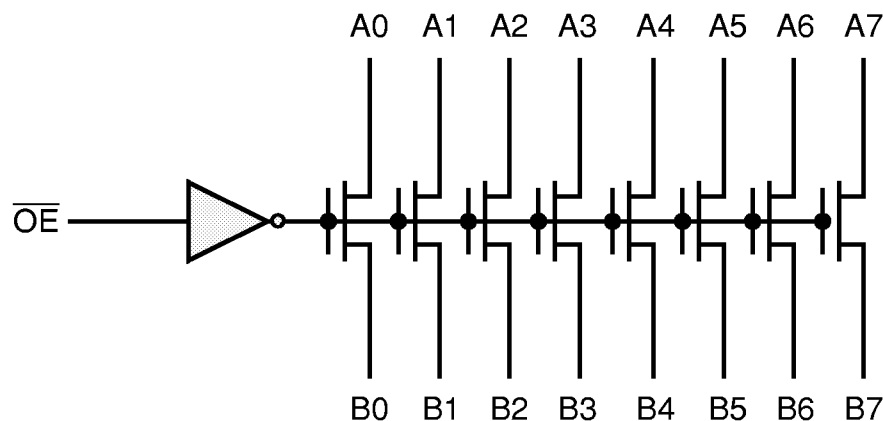

Table 1. Pin Description

Name	Description
\overline{OE}	Output Enable
An	Data I/Os
Bn	Data I/Os

**Figure 2. Pin Configuration
(All Pins Top View)**

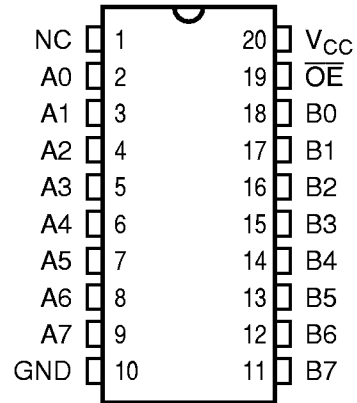

Table 2. Function Table

\overline{OE}	Outputs
H	Disconnected
L	An = Bn

Table 3. Absolute Maximum Rating

Supply Voltage to Ground	-0.5V to 4.6V
DC Switch Voltage V_S	-0.5V to 5.5V
DC Input Voltage V_{IN}	-0.5V to 5.5V
AC Input Voltage (for a pulse width ≤ 20 ns)	-3.0V
DC Output Current Max. Sink Current/Pin	120mA
Maximum Power Dissipation	0.5 watts
T_{STG} Storage Temperature	-65° to 150°C

Note: ABSOLUTE MAXIMUM CONTINUOUS RATINGS are those values beyond which damage to the device may occur. Exposure to these conditions or conditions beyond those indicated may adversely affect device reliability. Functional operation under absolute-maximum conditions is not implied.

Table 4. Capacitance

$T_A = 25^\circ\text{C}$, $f = 1\text{MHz}$, $V_{IN} = 0\text{V}$, $V_{OUT} = 0\text{V}$

Pins	QSOP, SOIC		Unit
	Typ	Max	
Control Inputs	3	5	pF
QuickSwitch Channels (Switch OFF)	4	6	pF

Note: Capacitance is guaranteed, but not production tested. For total capacitance while the switch is ON, please see Section 1 under "Input and Switch Capacitance".

QS3VH245, QS3VH2245

Table 5. DC Electrical Characteristics Over Operating Range

$T_A = -40^{\circ}\text{C}$ to 85°C , $V_{CC} = 3.3\text{V} \pm 0.3\text{V}$

Symbol	Parameter	Test Conditions	Min	Typ ⁽¹⁾	Max	Unit
V_{IH}	Input HIGH Voltage	Guaranteed Logic HIGH for Control Inputs	2.0	—	—	V
V_{IL}	Input LOW Voltage	Guaranteed Logic LOW for Control Inputs	—	—	0.8	V
$ I_{IN} $	Input Leakage Current	$0\text{V} \leq \overline{OE} \leq V_{CC}$	—	—	1	μA
$ I_{OZ} $	Off-State Current (Hi-Z)	$0\text{V} \leq A, B \leq V_{CC}$, Switches OFF	—	—	1	μA
R_{ON}	Switch ON Resistance ⁽²⁾	$V_{CC} = \text{Min.}, V_{IN} = 0.0\text{V}$ 3VH245	—	4	6	Ω
		$I_{ON} = 30\text{mA}$ 3VH2245	20	27	40	
R_{ON}	Switch ON Resistance ⁽²⁾	$V_{CC} = \text{Min.}, V_{IN} = 2.4\text{V}$ 3VH245	—	5	8	Ω
		$I_{ON} = 15\text{mA}$ 3VH2245	20	28	42	

Notes:

- Typical values indicate $V_{CC} = 3.3\text{V}$ and $T_A = 25^{\circ}\text{C}$.
- For a diagram explaining the procedure for R_{ON} measurement, please see Section 1, "DC Electrical Characteristics." R_{ON} guaranteed, but not production tested.

Figure 3. Typical ON Resistance vs V_{IN} at $V_{CC} = 3.3\text{V}$ (QS3VH245)

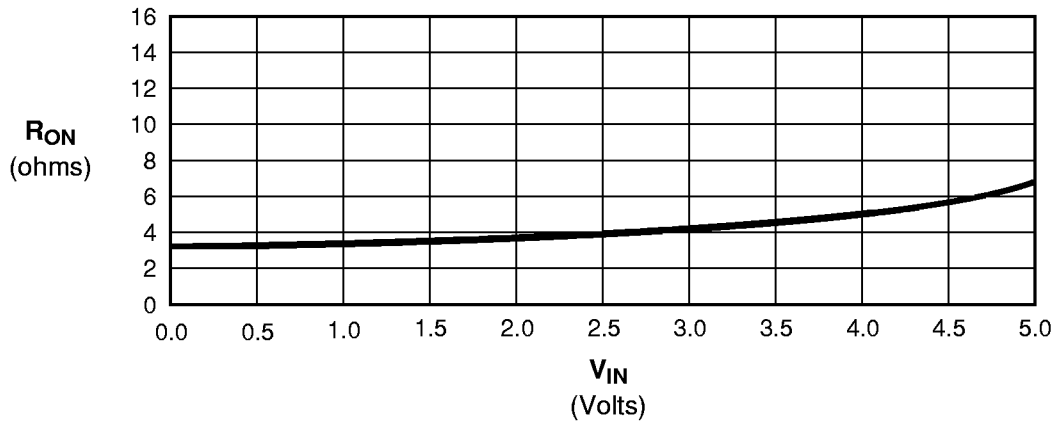

Note: For QS3VH2245, add 23Ω to R_{ON} shown.

QS3VH245, QS3VH2245

Table 6. Power Supply Characteristics Over Operating Range

$T_A = -40^\circ\text{C}$ to 85°C , $V_{CC} = 3.3\text{V} \pm 0.3\text{V}$

Symbol	Parameter	Test Conditions ⁽¹⁾	Max	Unit
I_{CCQ}	Quiescent Power Supply Current	$V_{CC} = \text{Max.}$, $V_{IN} = \text{GND}$ or V_{CC} , $f = 0$	3.0	mA
ΔI_{CC}	Power Supply Current ^(2,3) per Input HIGH	$V_{CC} = 3.6\text{V}$, $V_{IN} = 3.0\text{V}$, $f = 0$ per Control Input	30	μA
Q_{CCD}	Dynamic Power Supply Current per MHz ⁽⁴⁾	$V_{CC} = 3.6\text{V}$, A and B Pins Open, Control Input Toggling @ 50% Duty Cycle	0.25	mA/MHz

Notes:

- For conditions shown as Min. or Max., use the appropriate values specified under DC specifications.
- Per LVTTTL-driven-control input. A and B pins do not contribute to ΔI_{CC} .
- This parameter is guaranteed, but not production tested.
- This parameter represents the current required to switch internal capacitance at the specified frequency. The A and B inputs do not contribute to the Dynamic Power Supply Current. This parameter is guaranteed, but not production tested.

Table 7. Switching Characteristics Over Operating Range

$T_A = -40^\circ\text{C}$ to 85°C , $V_{CC} = 3.3\text{V} \pm 0.3\text{V}$

$C_{LOAD} = 50\text{pF}$, $R_{LOAD} = 500\Omega$ unless otherwise noted.

Symbol	Description ⁽¹⁾	QS3VH245			QS3VH2245			Unit
		Min ⁽⁴⁾	Typ	Max	Min ⁽⁴⁾	Typ	Max	
t_{PLH} t_{PHL}	Data Propagation Delay ^(2,3) An to/from Bn	—	—	0.25	—	—	1.25	ns
t_{PZL} t_{PZH}	Switch Turn-on Delay \overline{OE} to An/Bn	1.5	—	9.0	0.5	—	10	ns
t_{PLZ} t_{PHZ}	Switch Turn-off Delay ⁽²⁾ \overline{OE} to An/Bn	1.5	—	8.0	0.5	—	9	ns
f_S	Operating Frequency - Data ^(2,5) $\overline{OE} = \text{LOW}$	—	—	150	—	—	150	MHz
$f_{\overline{OE}}$	Operating Frequency - Enable ^(2,6)	—	—	1	—	—	1	MHz

Notes:

- See Test Circuit and Waveforms.
- This parameter is guaranteed, but not production tested.
- The bus switch contributes no propagation delay other than the RC delay of the ON resistance of the switch and the load capacitance. The time constant for the switch alone is of the order of 0.20ns for QS3VH245 and 1.25ns for QS3VH2245 for $C_L = 50\text{pF}$. Since this time constant is much smaller than the rise/fall times of typical driving signals, it adds very little propagation delay to the system. Propagation delay of the bus switch when used in a system is determined by the driving circuit on the driving side of the switch and its interaction with the load on the driven side.
- Minimums guaranteed, but not production tested.
- Maximum frequency for bidirectional data flow.
- Maximum toggle frequency for \overline{OE} control input.