

Product Features

- PI74AVC+16244 is designed for low-voltage operation, $V_{CC} = 1.65V$ to $3.6V$
- True $\pm 24mA$ Balanced Drive @ $3.3V$
- Compatible with Philips and T.I. AVC Logic family
- I_{OFF} supports partial power-down operation
- $3.6V$ I/O Tolerant inputs and outputs
- All outputs contain a patented DDC (Dynamic Drive Control) circuit that reduces noise without degrading propagation delay
- Industrial operation: $-40^{\circ}C$ to $+85^{\circ}C$
- Packaging (Pb-free & Green available):
 - 48-pin 240-mil wide plastic TSSOP
 - 48-pin 173-mil wide plastic TVSOP

Product Description

PI74AVC+16244 is a non-inverting 16-bit buffer/driver designed for low-voltage $1.65V$ to $3.6V$ V_{CC} operation.

The buffer/driver is designed specifically to improve both the performance and density of 3-state memory address drivers, clock drivers, and bus-oriented receivers and transmitters.

The device can be used as four 4-bit buffers, two 8-bit buffers, or one 16-bit buffer. It provides non-inverting outputs and symmetrical active-low output-enable (\overline{OE}) inputs.

To ensure the high-impedance state during power up or power down, \overline{OE} should be tied to V_{CC} through a pullup resistor in which the minimum value is determined by the current-sinking capability of the driver.

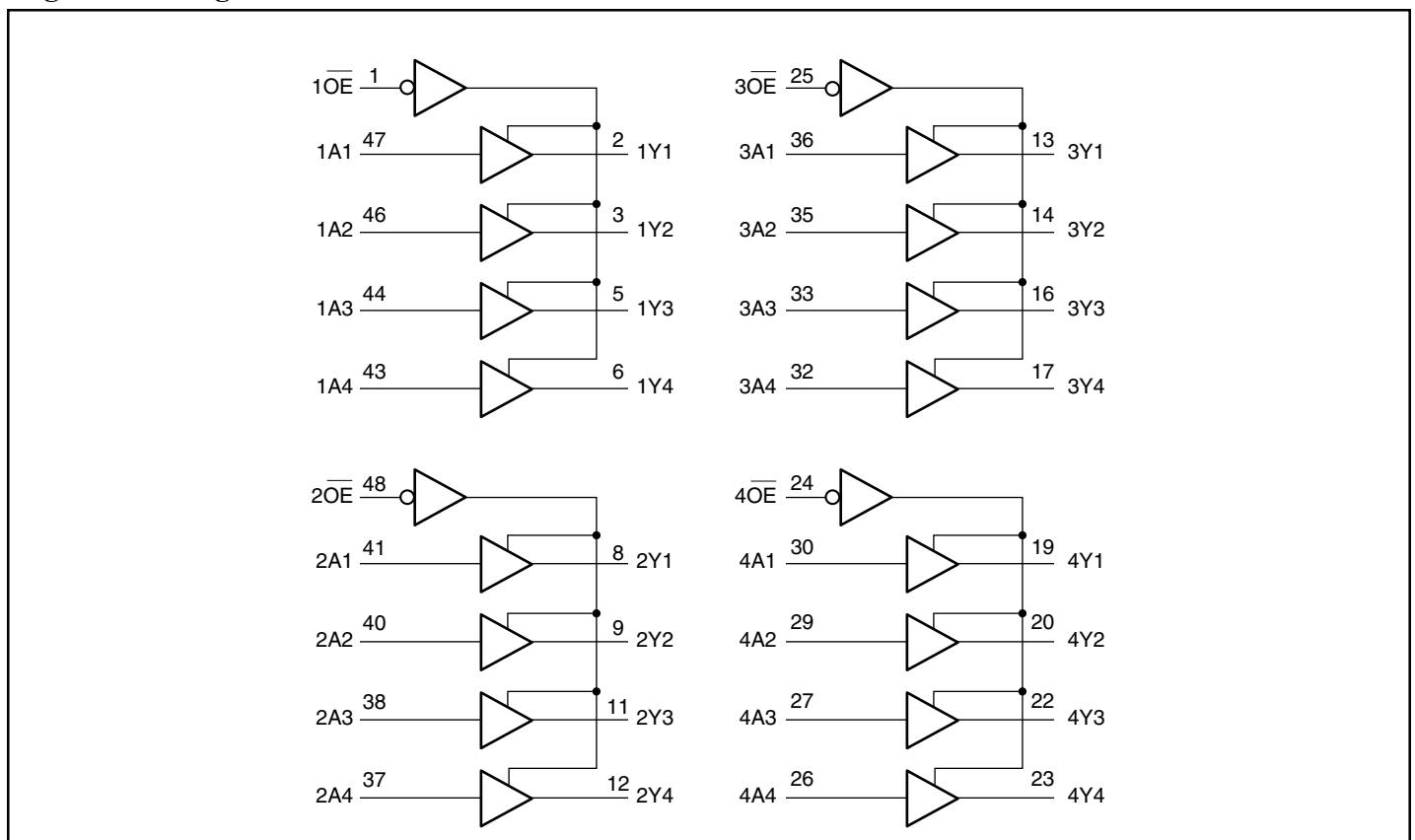
Logic Block Diagram

Maximum Ratings

(Above which the useful life may be impaired.
 For user guidelines, not tested.)

Supply voltage range, V_{CC}	-0.5V to +4.6V
Input voltage range, V_I	-0.5V to +4.6V
Voltage range applied to any output in the high-impedance or power-off state, $V_{O(1)}$	-0.5V to +4.6V
Voltage range applied to any output in the high or low state, $V_{O(1,2)}$	-0.5V to $V_{CC}+0.5V$
Input clamp current, $I_{IK} (V_I < 0)$	-50mA
Output clamp current, $I_{OK} (V_O < 0)$	-50mA
Continuous output current, I_O	$\pm 50mA$
Continuous current through each V_{CC} or GND	$\pm 100mA$
Package thermal impedance, $\theta_{JA}^{(3)}$: package A	64°C/W
package K	48°C/W
Storage Temperature range, T_{stg}	-65°C to 150°C

Notes:

Stresses greater than those listed under MAXIMUM RATINGS may cause permanent damage to the device. This is a stress rating only and functional operation of the device at these or any other conditions above those indicated in the operational sections of this specification is not implied. Exposure to absolute maximum rating conditions for extended periods may affect reliability.

1. Input & output negative-voltage ratings may be exceeded if the input and output current rating are observed.
2. Output positive-voltage rating may be exceeded up to 4.6V maximum if the output current rating is observed.
3. The package thermal impedance is calculated in accordance with JESD51.

Truth Table⁽¹⁾

Inputs		Outputs
\overline{nOE}	nAx	nYx
L	H	H
L	L	L
H	X	Z

Notes:

1. H = High Signal Level
 L = Low Signal Level
 X = Don't Care or Irrelevant
 Z = High Impedance

Product Pin Description

Pin Name	Description
\overline{nOE}	3-State Output Enable Inputs (Active LOW)
nAx	Inputs
nYx	3-State Outputs
GND	Ground
V_{CC}	Power

Product Pin Configuration

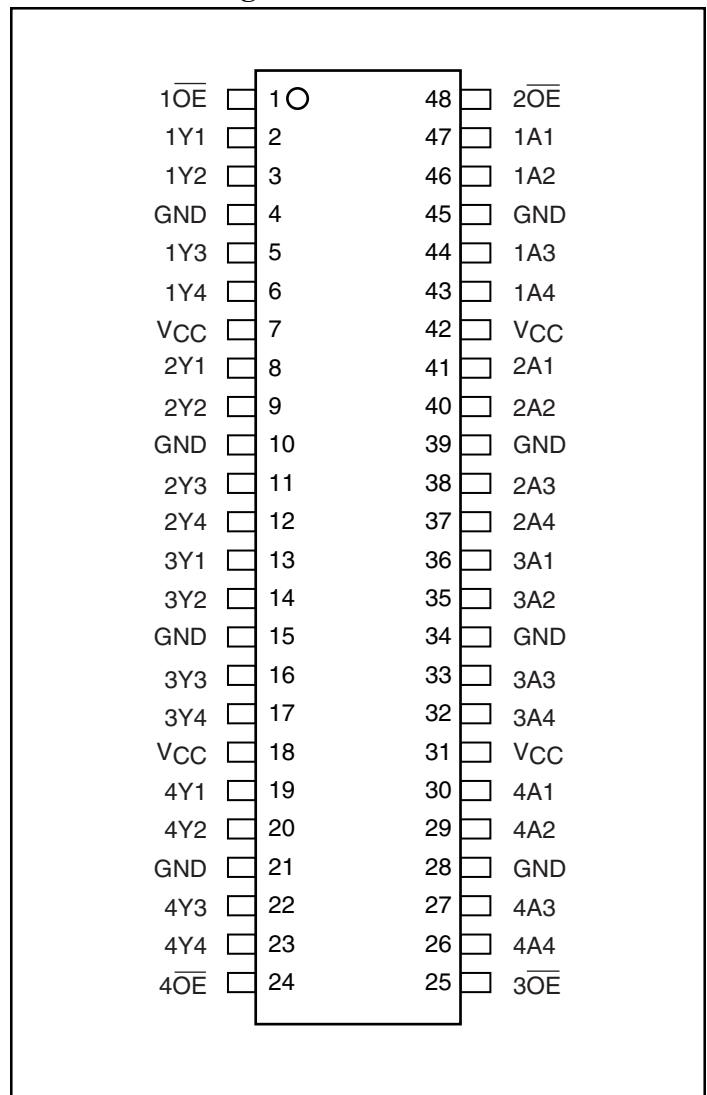

Recommended Operating Conditions⁽¹⁾

		Min.	Max.	Units
V _{CC} Supply Voltage	Operating	1.4	3.6	V
	Data retention only	1.2		
V _{IH} High-level Input Voltage	V _{CC} = 1.2V	V _{CC}		
	V _{CC} = 1.4V to 1.6V	0.65 x V _{CC}		
	V _{CC} = 1.65V to 1.95V	0.65 x V _{CC}		
	V _{CC} = 2.3V to 2.7V	1.7		
	V _{CC} = 3V to 3.6V	2		
V _{IL} Low-level Input Voltage	V _{CC} = 1.2V		GND	
	V _{CC} = 1.4V to 1.6V		0.35 x V _{CC}	
	V _{CC} = 1.65V to 1.95V		0.35 x V _{CC}	
	V _{CC} = 2.3V to 2.7V		0.7	
	V _{CC} = 3V to 3.6V		0.8	
V _I Input Voltage		0	3.6	
V _O Output Voltage	Active State	0	V _{CC}	
	3-State	0	3.6	
I _{OHS} High-level output current	V _{CC} = 1.4V to 1.6V		-4	mA
	V _{CC} = 1.65V to 1.95V		-6	
	V _{CC} = 2.3V to 2.7V		-12	
	V _{CC} = 3V to 3.6V		-24	
I _{OIS} Low-level output current	V _{CC} = 1.4V to 1.6V		4	
	V _{CC} = 1.65V to 1.95V		6	
	V _{CC} = 2.3V to 2.7V		12	
	V _{CC} = 3V to 3.6V		24	
ΔtΔv Input transition rise or fall rate	V _{CC} = 1.4V to 3.6V		5	ns/V
T _A Operating free-air temperature		-40	85	°C

Notes:

1. All unused inputs must be held at V_{CC} or GND to ensure proper device operation.

DC Electrical Characteristics (Over the Operating Range, $T_A = -40^\circ\text{C} + 85^\circ\text{C}$)

Parameters		Test Conditions ⁽¹⁾	V _{CC}	Min.	Typ.	Max.	Units
V _{OH}		I _{OH} = -100μA	1.4V to 3.6V	V _{CC} - 0.2V			V
		I _{OHS} = -4mA V _{IH} = 0.91V	1.4V	1.05			
		I _{OHS} = -6mA V _{IH} = 1.07V	1.65V	1.2			
		I _{OHS} = -12mA V _{IH} = 1.7V	2.3V	1.75			
		I _{OHS} = -24mA V _{IH} = 2V	3V	2.0			
V _{OL}		I _{OLS} = 100μA	1.4V to 3.6V			0.2	
		I _{OLS} = 4mA V _{IL} = 0.49V	1.4V			0.4	
		I _{OLS} = 6mA V _{IL} = 0.57V	1.65V			0.45	
		I _{OLS} = 12mA V _{IL} = 0.7V	2.3V			0.55	
		I _{OLS} = 24mA V _{IL} = 0.8V	3V			0.8	
I _I		V _I = V _{CC} or GND	3.6V			±2.5	μA
I _{OFF}		V _I or V _O = 3.6V	0			±10	
I _{OZ}		V _O = V _{CC} or GND	3.6V			±10	
I _{CC}		V _I = V _{CC} or GND I _O = 0	3.6V			40	
C _I	Control Inputs	V _I = V _{CC} or GND	2.5V		3.5		pF
			3.3V		3.5		
	Data Inputs		2.5V		6		
			3.3V		6		
C _O	Outputs	V _O = V _{CC} or GND	2.5V		6.5		
			3.3V		6.5		

Notes:

1. Typical values are measured at $T_A = 25^\circ\text{C}$.

Switching Characteristics

(Over recommended operating free-air temperature range, unless otherwise noted, see Figures 1 thru 4)

Parameters	From (Input)	To (Output)	V _{CC} = 1.2V	V _{CC} = 1.5V ± 0.1V		V _{CC} = 1.8V ± 0.15V		V _{CC} = 2.5V ± 0.2V		V _{CC} = 3.3V ± 0.3V		Units
			Typ.	Min.	Max.	Min.	Max.	Min.	Max.	Min.	Max.	
t _{pd}	A	Y	3.1	0.6	3.3	0.7	2.9	0.6	1.9	0.5	1.7	ns
t _{en}	$\overline{\text{OE}}$	Y	7.6	1.4	8	1.3	6.8	0.9	4.0	0.7	3.5	
t _{dis}	$\overline{\text{OE}}$	Y	7.2	1.7	7.3	1.6	6.2	1.0	4.3	1.0	3.5	

Operating Characteristics, T_A=25°C

Parameters		Test Conditions	V _{CC} = 1.8V ± 0.15V	V _{CC} = 2.5V ± 0.2V	V _{CC} = 3.3V ± 0.3V	Units
			Typical	Typical	Typical	
C _{pd} Power Dissipation Capacitance	Outputs Enabled	C _L = 0pF, f = 10 MHz	23	27	33	pF
	Outputs Disabled		0.1	0.1	0.1	

PARAMETER MEASUREMENT INFORMATION

$V_{CC} = 1.2V$ and $1.5V \pm 0.1V$

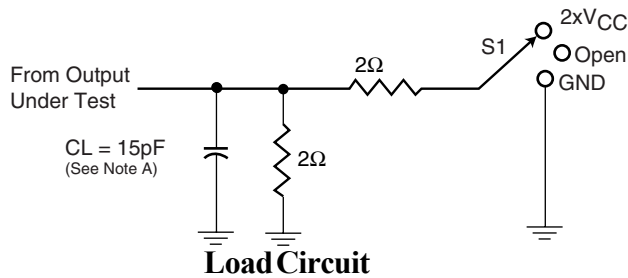

Test	S1
t_{pd} t_{PLZ}/t_{PZL} t_{PHZ}/t_{PZH}	Open 2 x V_{CC} GND

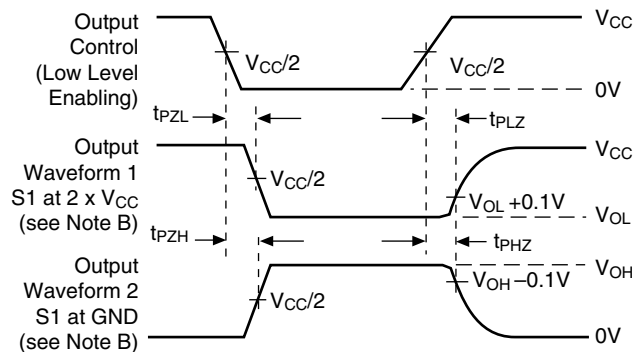
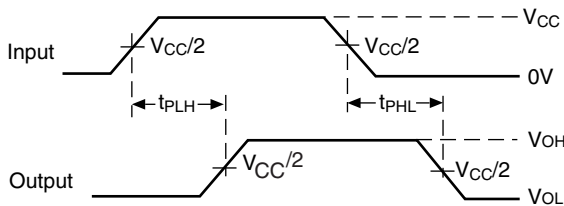
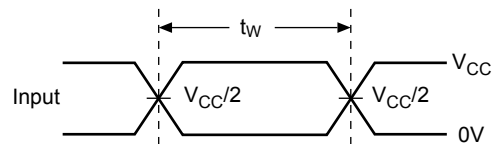
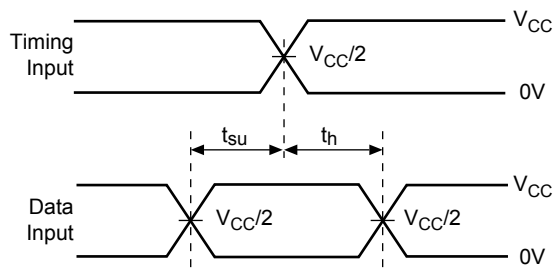

Figure 1. Load Circuit and Voltage Waveforms

Notes:

- A. C_L includes probe and jig capacitance.
- B. Waveform 1 is for an output with internal conditions such that the output is low except when disabled by the output control. Waveform 2 is for an output with internal conditions such that the output is high except when disabled by the output control.
- All input impulses are supplied by generators having the following characteristics: $PRR \leq 10$ MHz, $Z_O = 50\Omega$, $t_R \leq 2.0ns$, $t_F \leq 2.0ns$.
- The outputs are measured one at a time with one transition per measurement.
- t_{PLZ} and t_{PHZ} are the same as t_{dis}
- t_{PZL} and t_{PZH} are the same as t_{en}
- t_{PLH} and t_{PHL} are the same as t_{pd}

PARAMETER MEASUREMENT INFORMATION

$V_{CC} = 1.8V \pm 0.15V$

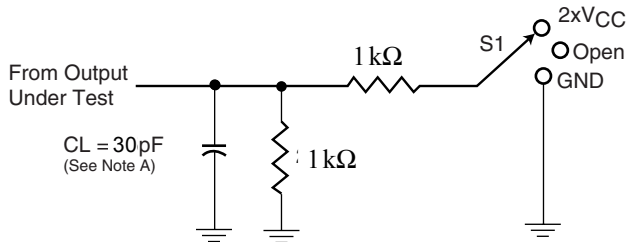

Load Circuit

Test	S1
t_{pd} t_{PLZ}/t_{PZL} t_{PHZ}/t_{PZH}	Open 2 x V_{CC} GND

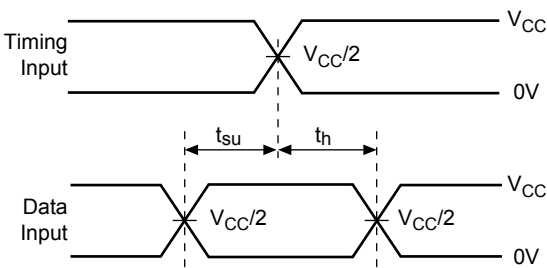

Voltage Waveforms
Setup and Hold Times

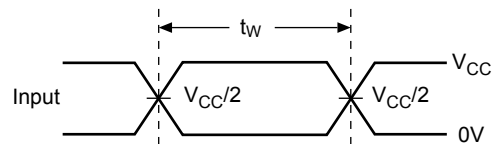

Voltage Waveforms
Pulse Duration

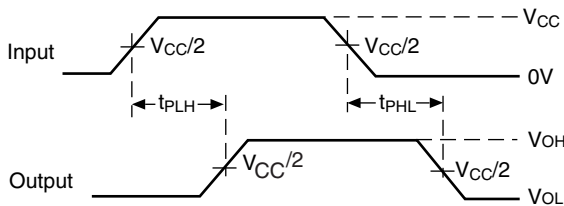

Voltage Waveforms
Propagation Delay Times

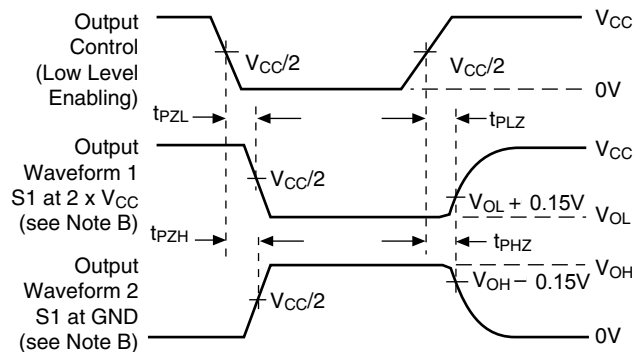

Voltage Waveforms
Enable and Disable Times

Figure 2. Load Circuit and Voltage Waveforms

Notes:

- A. C_L includes probe and jig capacitance.
- B. Waveform 1 is for an output with internal conditions such that the output is low except when disabled by the output control. Waveform 2 is for an output with internal conditions such that the output is high except when disabled by the output control.
- All input impulses are supplied by generators having the following characteristics: $PRR \leq 10 \text{ MHz}$, $Z_O = 50\Omega$, $t_R \leq 2.0ns$, $t_F \leq 2.0ns$.
- The outputs are measured one at a time with one transition per measurement.
- t_{PLZ} and t_{PHZ} are the same as t_{dis}
- t_{PZL} and t_{PZH} are the same as t_{en}
- t_{PLH} and t_{PHL} are the same as t_{pd}

PARAMETER MEASUREMENT INFORMATION

$V_{CC} = 2.5V \pm 0.2V$

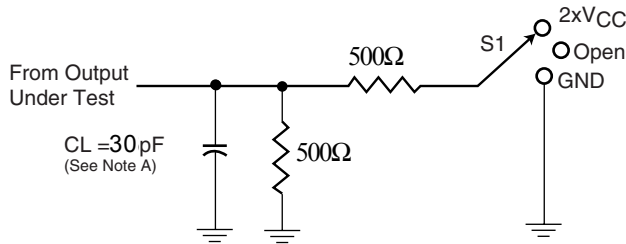

Load Circuit

Test	S1
t _{pd} t _{PLZ} /t _{PZL} t _{PHZ} /t _{PZH}	Open 2 x V _{CC} GND

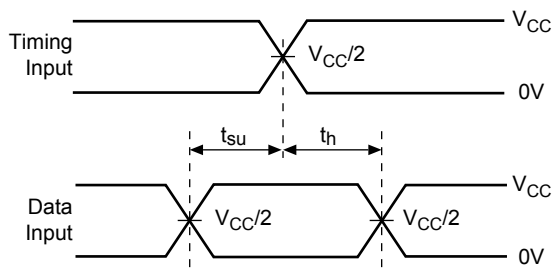

Voltage Waveforms
Setup and Hold Times

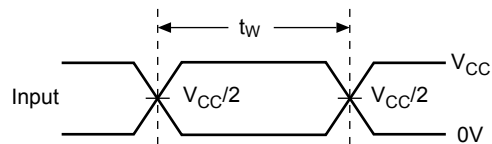

Voltage Waveforms
Pulse Duration

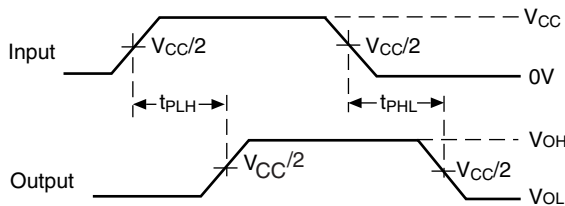

Voltage Waveforms
Propagation Delay Times

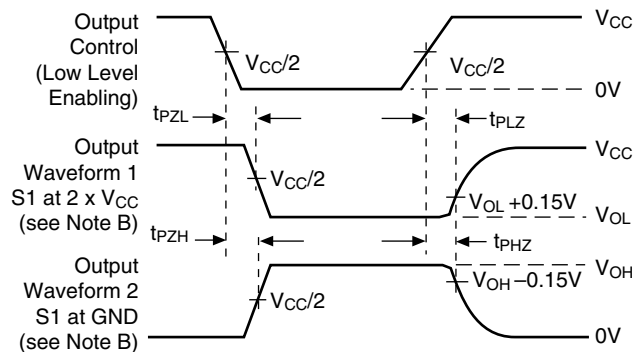

Voltage Waveforms
Enable and Disable Times

Figure 3. Load Circuit and Voltage Waveforms

Notes:

- A. C_L includes probe and jig capacitance.
- B. Waveform 1 is for an output with internal conditions such that the output is low except when disabled by the output control. Waveform 2 is for an output with internal conditions such that the output is high except when disabled by the output control.
- All input impulses are supplied by generators having the following characteristics: PRR ≤ 10 MHz, Z_O = 50Ω, t_R ≤ 2.0ns, t_F ≤ 2.0ns.
- The outputs are measured one at a time with one transition per measurement.
- t_{PLZ} and t_{PHZ} are the same as t_{dis}
- t_{PZL} and t_{PZH} are the same as t_{en}
- t_{PLH} and t_{PHL} are the same as t_{pd}

PARAMETER MEASUREMENT INFORMATION

$V_{CC} = 3.3V \pm 0.3V$

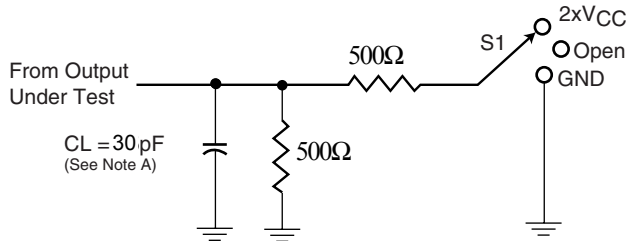

Load Circuit

Test	S1
t_{pd} t_{PLZ}/t_{PZL} t_{PHZ}/t_{PZH}	Open $2 \times V_{CC}$ GND

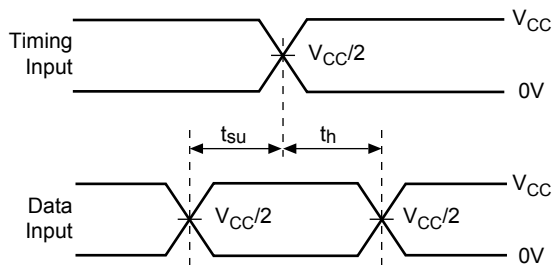

Voltage Waveforms
Setup and Hold Times

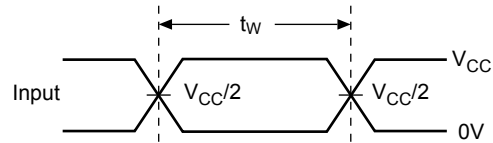

Voltage Waveforms
Pulse Duration

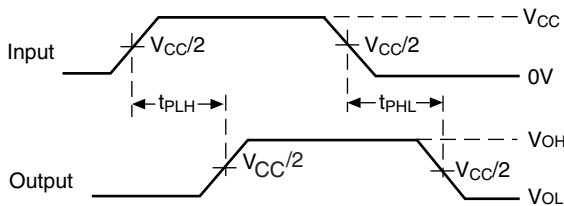

Voltage Waveforms
Propagation Delay Times

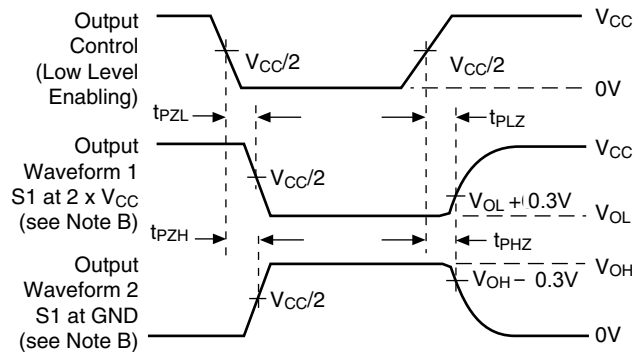

Voltage Waveforms
Enable and Disable Times

Figure 4. Load Circuit and Voltage Waveforms

Notes:

- A. C_L includes probe and jig capacitance.
- B. Waveform 1 is for an output with internal conditions such that the output is low except when disabled by the output control. Waveform 2 is for an output with internal conditions such that the output is high except when disabled by the output control.
- All input impulses are supplied by generators having the following characteristics: $PRR \leq 10 \text{ MHz}$, $Z_O = 50\Omega$, $t_R \leq 2.0\text{ns}$, $t_F \leq 2.0\text{ns}$.
- The outputs are measured one at a time with one transition per measurement.
- t_{PLZ} and t_{PHZ} are the same as t_{dis}
- t_{PZL} and t_{PZH} are the same as t_{en}
- t_{PLH} and t_{PHL} are the same as t_{pd}

Packaging Mechanical: 48-pin TSSOP (A)

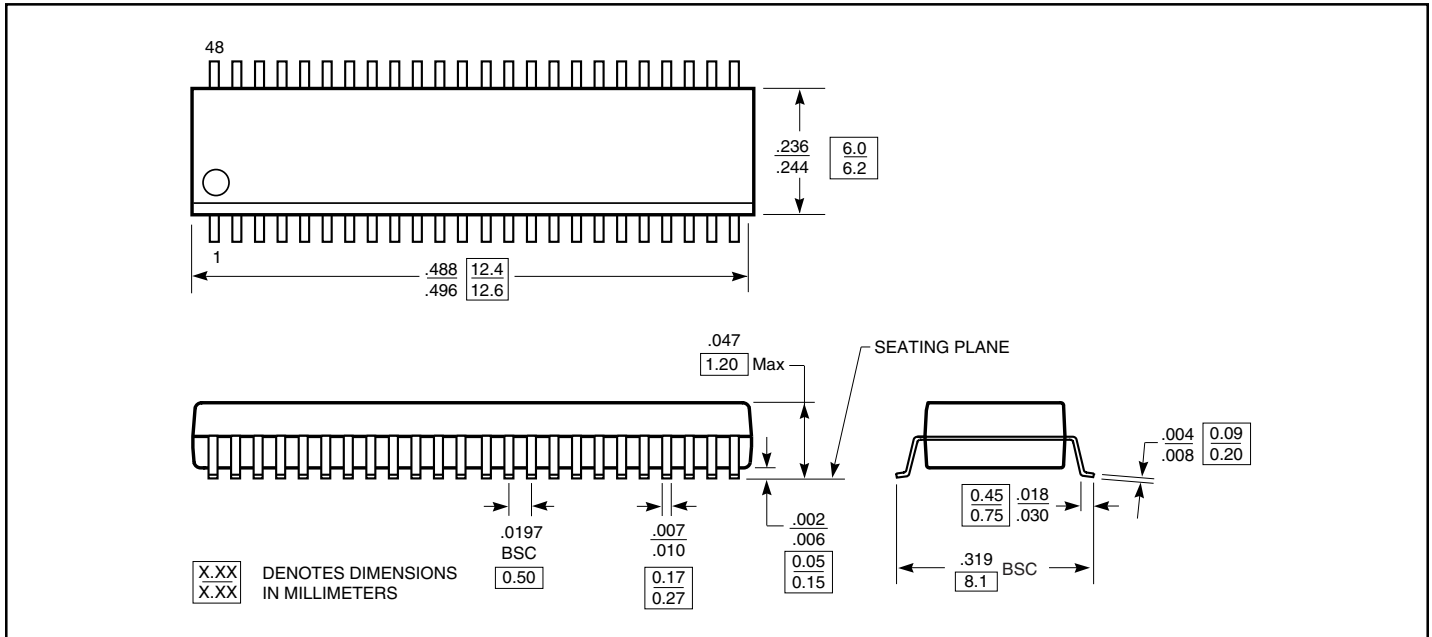

Packaging Mechanical: 48-pin TVSOP (TSSOP) (K)

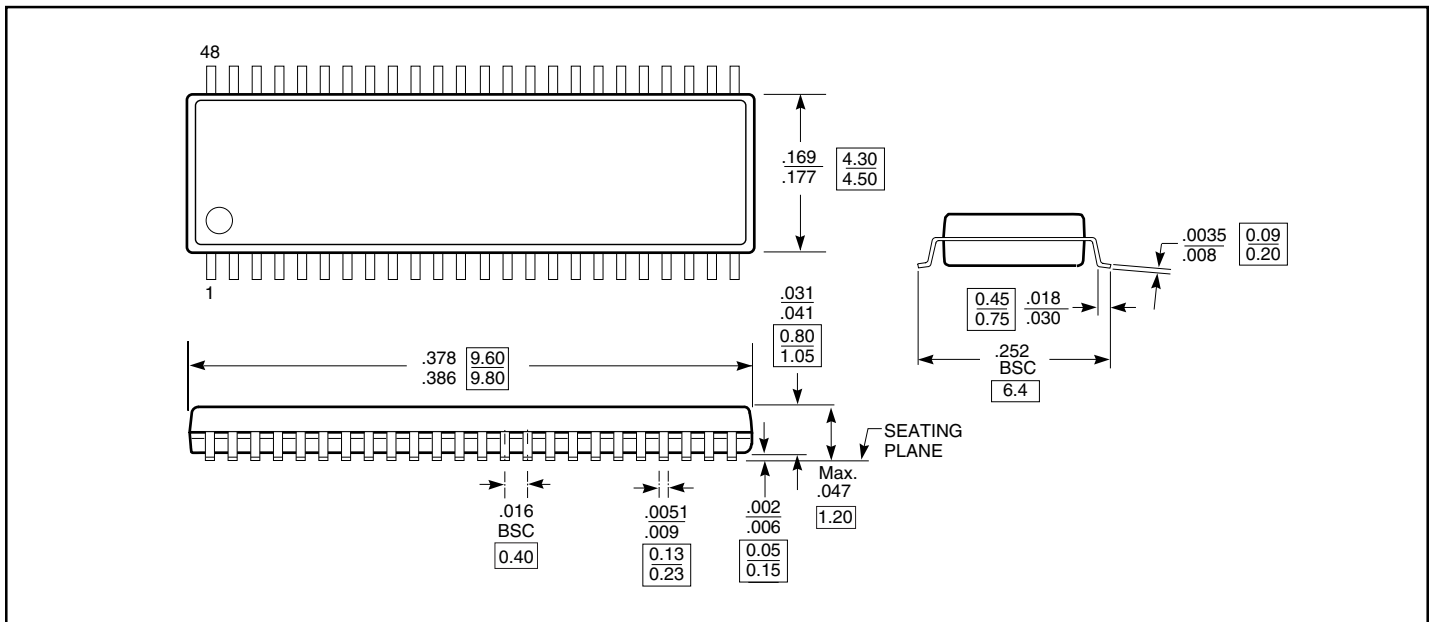



Ordering Information

Ordering Code	Package Type	Package Description
PI74AVC+16244A	A	48-pin, 240-mil wide plastic TSSOP
PI74AVC+16244AE	A	Pb-free & Green, 48-pin, 240-mil wide plastic TSSOP
PI74AVC+16244K	K	48-pin, 173-mil wide plastic TVSOP
PI74AVC+16244KE	K	Pb-free & Green, 48-pin, 173-mil wide plastic TVSOP

Notes:

- Thermal characteristics can be found on the company web site at www.pericom.com/packaging/
- E = Pb-free & Green
- Adding an X suffix = Tape/Reel