

## Dual 4-Bit Latch

The MC14508B dual 4-bit latch is constructed with MOS P-channel and N-channel enhancement mode devices in a single monolithic structure. The part consists of two identical, independent 4-bit latches with separate Strobe (ST) and Master Reset (MR) controls. Separate Disable inputs force the outputs to a high impedance state and allow the devices to be used in time sharing bus line applications.

These complementary MOS latches find primary use in buffer storage, holding register, or general digital logic functions where low power dissipation and/or high noise immunity is desired.

- 3-State Output
- Supply Voltage Range = 3.0 Vdc to 18 Vdc
- Capable of Driving Two Low-power TTL Loads or One Low-power Schottky TTL Load over the Rated Temperature Range

### MAXIMUM RATINGS\* (Voltages Referenced to V<sub>SS</sub>)

Symbol	Parameter	Value	Unit
V <sub>DD</sub>	DC Supply Voltage	- 0.5 to + 18.0	V
V <sub>in</sub> , V <sub>out</sub>	Input or Output Voltage (DC or Transient)	- 0.5 to V <sub>DD</sub> + 0.5	V
I <sub>in</sub> , I <sub>out</sub>	Input or Output Current (DC or Transient), per Pin	± 10	mA
P <sub>D</sub>	Power Dissipation, per Package†	500	mW
T <sub>stg</sub>	Storage Temperature	- 65 to + 150	°C
T <sub>L</sub>	Lead Temperature (8-Second Soldering)	260	°C

\* Maximum Ratings are those values beyond which damage to the device may occur.

† Temperature Derating:

Plastic "P and D/DW" Packages: - 7.0 mW/°C From 65°C To 125°C

Ceramic "L" Packages: - 12 mW/°C From 100°C To 125°C

### TRUTH TABLE

MR	ST	Disable	D3	D2	D1	D0	Q3	Q2	Q1	Q0
0	1	0	0	0	0	0	0	0	0	0
0	1	0	0	0	0	1	0	0	0	1
0	1	0	0	0	1	0	0	0	1	0
0	1	0	0	1	0	0	0	1	0	0
0	1	0	1	0	0	0	1	0	0	0
0	0	0	X	X	X	X	Latched			
1	X	0	X	X	X	X	0	0	0	0
X	X	1	X	X	X	X	High Impedance			

X = Don't Care

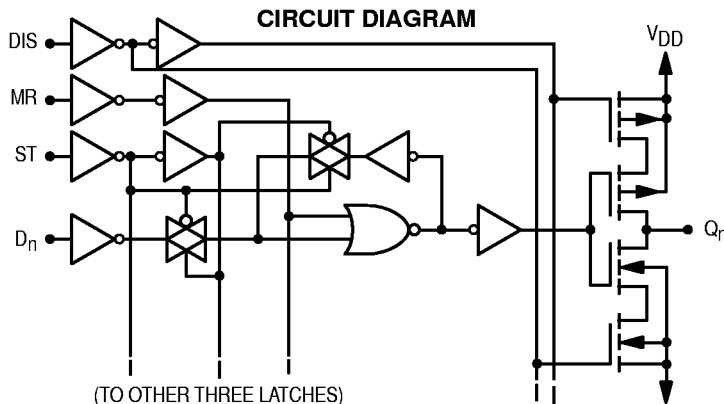

## MC14508B

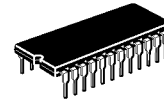

**L SUFFIX**  
CERAMIC  
CASE 623

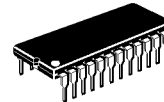

**P SUFFIX**  
PLASTIC  
CASE 709



**DW SUFFIX**  
SOIC  
CASE 751E

### ORDERING INFORMATION

MC14XXXBCP Plastic  
MC14XXXBCL Ceramic  
MC14XXXBDW SOIC

T<sub>A</sub> = - 55° to 125°C for all packages.

### BLOCK DIAGRAM

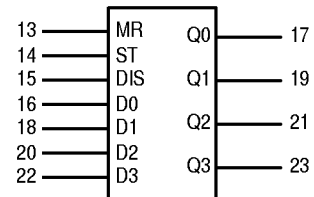
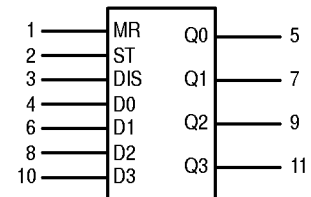

V<sub>DD</sub> = PIN 24  
V<sub>SS</sub> = PIN 12

**ELECTRICAL CHARACTERISTICS** (Voltages Referenced to  $V_{SS}$ )

Characteristic	Symbol	$V_{DD}$ Vdc	-55°C		25°C			125°C		Unit
			Min	Max	Min	Typ #	Max	Min	Max	
Output Voltage $V_{in} = V_{DD}$ or 0  $V_{in} = 0$ or $V_{DD}$	"0" Level  $V_{OL}$	5.0	—	0.05	—	0	0.05	—	0.05	Vdc
		10	—	0.05	—	0	0.05	—	0.05	
		15	—	0.05	—	0	0.05	—	0.05	
	"1" Level  $V_{OH}$	5.0	4.95	—	4.95	5.0	—	4.95	—	Vdc
		10	9.95	—	9.95	10	—	9.95	—	
		15	14.95	—	14.95	15	—	14.95	—	
Input Voltage "0" Level ( $V_O = 4.5$ or $0.5$ Vdc) ( $V_O = 9.0$ or $1.0$ Vdc) ( $V_O = 13.5$ or $1.5$ Vdc)  "1" Level ( $V_O = 0.5$ or $4.5$ Vdc) ( $V_O = 1.0$ or $9.0$ Vdc) ( $V_O = 1.5$ or $13.5$ Vdc)	$V_{IL}$	5.0	—	1.5	—	2.25	1.5	—	1.5	Vdc
		10	—	3.0	—	4.50	3.0	—	3.0	
		15	—	4.0	—	6.75	4.0	—	4.0	
	$V_{IH}$	5.0	3.5	—	3.5	2.75	—	3.5	—	Vdc
		10	7.0	—	7.0	5.50	—	7.0	—	
		15	11	—	11	8.25	—	11	—	
Output Drive Current ( $V_{OH} = 2.5$ Vdc) ( $V_{OH} = 4.6$ Vdc) ( $V_{OH} = 9.5$ Vdc) ( $V_{OH} = 13.5$ Vdc)  ( $V_{OL} = 0.4$ Vdc) ( $V_{OL} = 0.5$ Vdc) ( $V_{OL} = 1.5$ Vdc)	Source  $I_{OH}$	5.0	-3.0	—	-2.4	-4.2	—	-1.7	—	mAdc
		5.0	-0.64	—	-0.51	-0.88	—	-0.36	—	
		10	-1.6	—	-1.3	-2.25	—	-0.9	—	
		15	-4.2	—	-3.4	-8.8	—	-2.4	—	
	Sink  $I_{OL}$	5.0	0.64	—	0.51	0.88	—	0.36	—	mAdc
		10	1.6	—	1.3	2.25	—	0.9	—	
15		4.2	—	3.4	8.8	—	2.4	—		
Input Current	$I_{in}$	15	—	$\pm 0.1$	—	$\pm 0.00001$	$\pm 0.1$	—	$\pm 1.0$	$\mu$ Adc
Input Capacitance ( $V_{in} = 0$ )	$C_{in}$	—	—	—	—	5.0	7.5	—	—	pF
Quiescent Current (Per Package)	$I_{DD}$	5.0	—	5.0	—	0.005	5.0	—	150	$\mu$ Adc
		10	—	10	—	0.010	10	—	300	
		15	—	20	—	0.015	20	—	600	
Total Supply Current**† (Dynamic plus Quiescent, Per Package) ( $C_L = 50$ pF on all outputs, all buffers switching)	$I_T$	5.0	$I_T = (1.46 \mu A/kHz) f + I_{DD}$							$\mu$ Adc
		10	$I_T = (2.91 \mu A/kHz) f + I_{DD}$							
		15	$I_T = (4.37 \mu A/kHz) f + I_{DD}$							
Three-State Leakage Current	$I_{TL}$	15	—	$\pm 0.1$	—	$\pm 0.0001$	$\pm 0.1$	—	$\pm 3.0$	$\mu$ Adc

#Data labelled "Typ" is not to be used for design purposes but is intended as an indication of the IC's potential performance.

\*\*The formulas given are for the typical characteristics only at 25°C.

†To calculate total supply current at loads other than 50 pF:

$$I_T(C_L) = I_T(50 \text{ pF}) + (C_L - 50) Vfk$$

where:  $I_T$  is in  $\mu A$  (per package),  $C_L$  in pF,  $V = (V_{DD} - V_{SS})$  in volts,  $f$  in kHz is input frequency, and  $k = 0.008$ .

This device contains protection circuitry to guard against damage due to high static voltages or electric fields. However, precautions must be taken to avoid applications of any voltage higher than maximum rated voltages to this high-impedance circuit. For proper operation,  $V_{in}$  and  $V_{out}$  should be constrained to the range  $V_{SS} \leq (V_{in} \text{ or } V_{out}) \leq V_{DD}$ . Unused inputs must always be tied to an appropriate logic voltage level (e.g., either  $V_{SS}$  or  $V_{DD}$ ). Unused outputs must be left open.

**SWITCHING CHARACTERISTICS\*** ( $C_L = 50 \text{ pF}$ ,  $T_A = 25^\circ\text{C}$ )

Characteristic	Symbol	$V_{DD}$	All Types			Unit
			Min	Typ #	Max	
Output Rise and Fall Time $t_{TLH}$ , $t_{THL} = (1.5 \text{ ns/pF}) C_L + 25 \text{ ns}$ $t_{TLH}$ , $t_{THL} = (0.75 \text{ ns/pF}) C_L + 12.5 \text{ ns}$ $t_{TLH}$ , $t_{THL} = (0.55 \text{ ns/pF}) C_L + 9.5 \text{ ns}$	$t_{TLH}$ , $t_{THL}$	5.0 10 15	— — —	100 50 40	200 100 80	ns
Propagation Delay Time, Dn or MR to Q $t_{PLH}$ , $t_{PHL} = (1.7 \text{ ns/pF}) C_L + 135 \text{ ns}$ $t_{PLH}$ , $t_{PHL} = (0.66 \text{ ns/pF}) C_L + 57 \text{ ns}$ $t_{PLH}$ , $t_{PHL} = (0.5 \text{ ns/pF}) C_L + 35 \text{ ns}$	$t_{PLH}$ , $t_{PHL}$	5.0 10 15	— — —	220 90 60	440 180 120	ns
Master Reset Pulse Width	$t_{WH(R)}$	5.0 10 15	200 100 70	100 50 35	— — —	ns
Master Reset Removal Time	$t_{rem}$	5.0 10 15	30 25 20	- 15 0 0	— — —	ns
Strobe Pulse Width	$t_{WH(S)}$	5.0 10 15	140 70 40	70 35 20	— — —	ns
Setup Time Data to Strobe	$t_{su}$	5.0 10 15	50 20 10	25 10 5.0	— — —	ns
Hold Time Strobe to Data	$t_h$	5.0 10 15	50 35 35	20 10 10	— — —	ns
3-State Propagation Delay Time Output "1" to High Impedance	$t_{PHZ}$	5.0 10 15	— — —	55 35 30	170 100 70	ns
Output "0" to High Impedance	$t_{PLZ}$	5.0 10 15	— — —	75 40 35	170 100 70	
High Impedance to "1" Level	$t_{PZH}$	5.0 10 15	— — —	80 35 30	170 100 70	
High Impedance to "0" Level	$t_{PZL}$	5.0 10 15	— — —	105 50 35	210 100 70	

\* The formulas given are for the typical characteristics only at 25°C.

#Data labelled "Typ" is not to be used for design purposes but is intended as an indication of the IC's potential performance.

**PIN ASSIGNMENT**

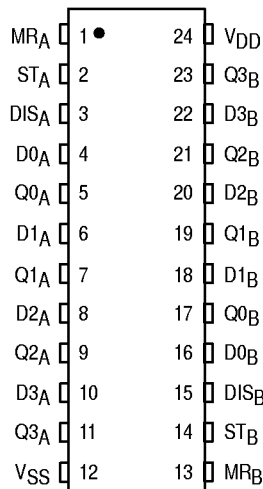

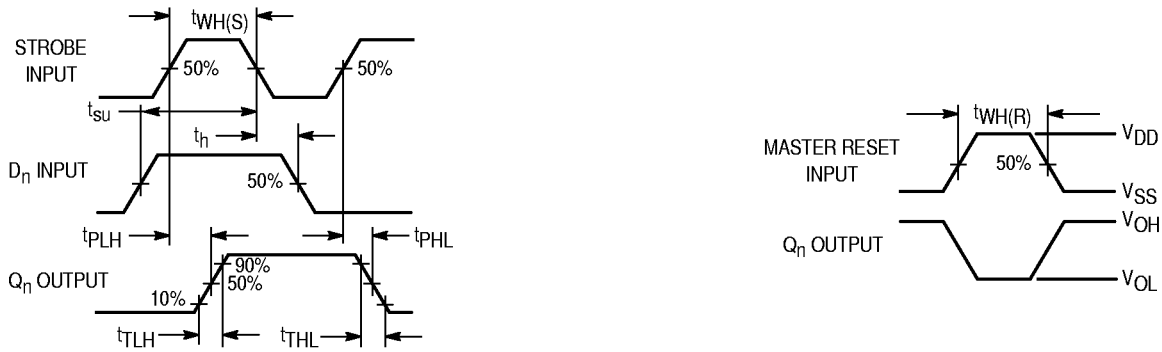
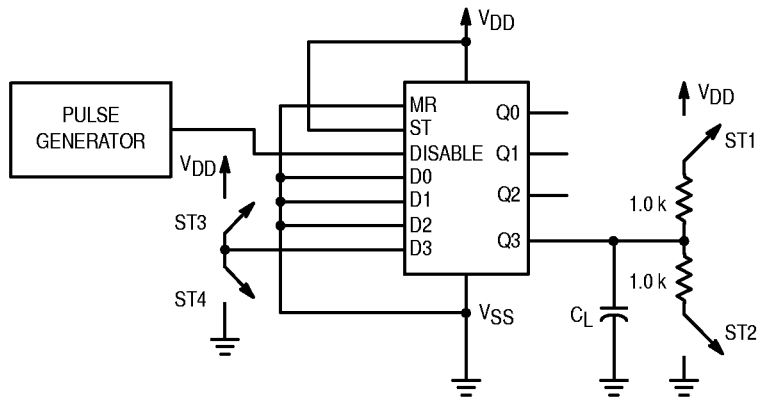

Figure 1. AC Waveforms



Test	ST1	ST2	ST3	ST4
tPHZ	Open	Close	Close	Open
tPLZ	Close	Open	Open	Close
tPZL	Close	Open	Open	Close
tPZH	Open	Close	Close	Open

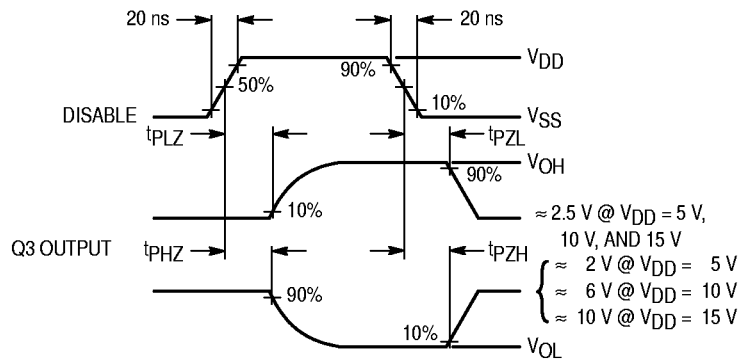

Figure 2. 3-State AC Test Circuit and Waveforms

### 3-STATE MODE OF OPERATION

The MC14508B can be used in bussed systems as shown. The output terminals of N 4-bit latches can be directly wired to a bus line, and to one of the 4-bit latches selected. The selected latch controls the logic state of the bus line and the remaining (N-1) 4-bit latches are disabled into a high impedance "off" state. The number of latches, N, which may be connected to a bus line is determined from the output drive current,  $I_{OD}$ , the 3-state or disabled output leakage current,  $I_{TL}$ , and the load current,  $I_L$ , required to drive the bus line (including fanout to other device inputs) and can be calculated by the following:

$$N = \frac{I_{OD} - I_L}{I_{TL}} + 1$$

N must be calculated for both high and low logic states of the bus line.

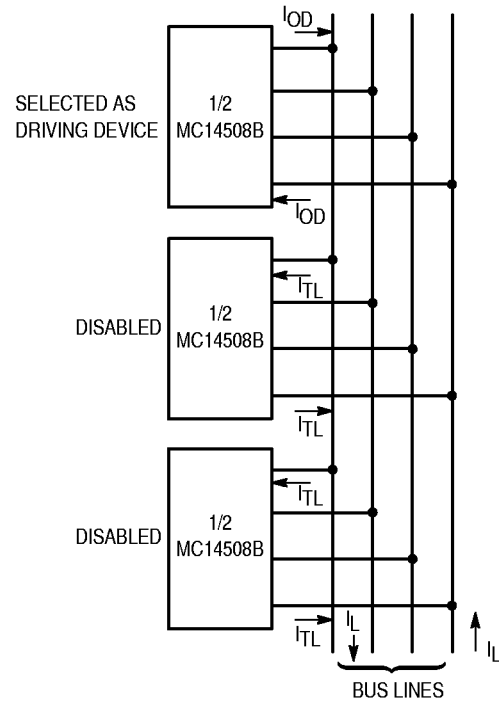

### TYPICAL 3-STATE APPLICATIONS

#### EXAMPLE 1

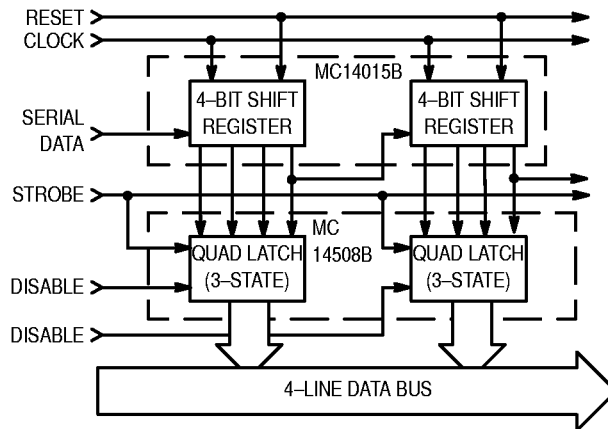

#### EXAMPLE 2

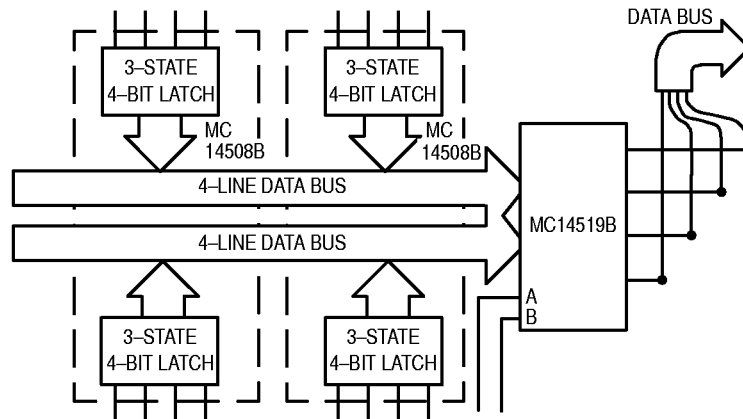

## OUTLINE DIMENSIONS

### L SUFFIX CERAMIC DIP PACKAGE CASE 623-05 ISSUE M

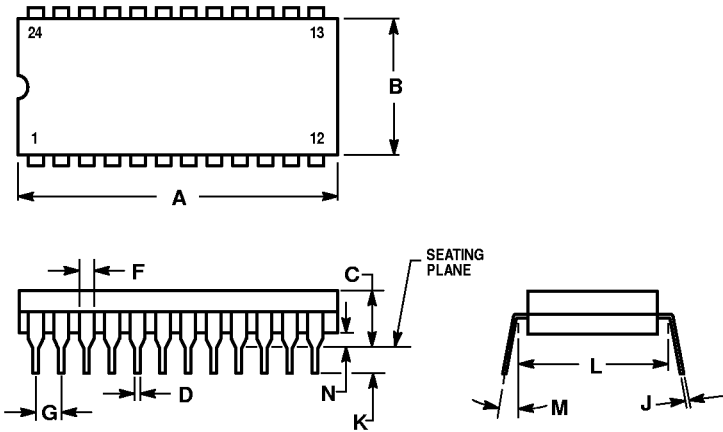

**NOTES:**

1. DIMENSION L TO CENTER OF LEADS WHEN FORMED PARALLEL.
2. LEADS WITHIN 0.13 (0.005) RADIUS OF TRUE POSITION AT SEATING PLANE AT MAXIMUM MATERIAL CONDITION (WHEN FORMED PARALLEL).

DIM	MILLIMETERS		INCHES	
	MIN	MAX	MIN	MAX
A	31.24	32.77	1.230	1.290
B	12.70	15.49	0.500	0.610
C	4.06	5.59	0.160	0.220
D	0.41	0.51	0.016	0.020
F	1.27	1.52	0.050	0.060
G	2.54 BSC		0.100 BSC	
J	0.20	0.30	0.008	0.012
K	3.18	4.06	0.125	0.160
L	15.24 BSC		0.600 BSC	
M	0°	15°	0°	15°
N	0.51	1.27	0.020	0.050

### P SUFFIX PLASTIC DIP PACKAGE CASE 709-02 ISSUE C

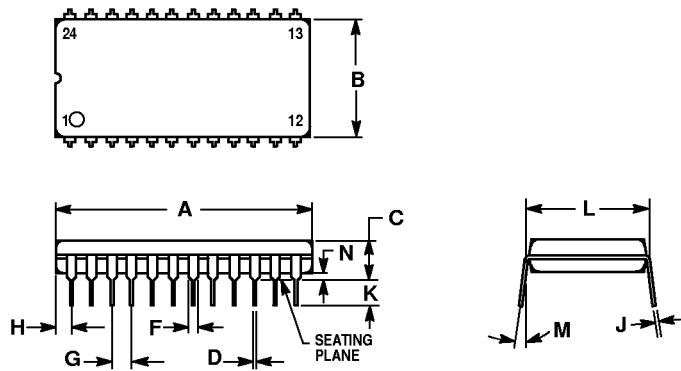

**NOTES:**

1. POSITIONAL TOLERANCE OF LEADS (D), SHALL BE WITHIN 0.25 (0.010) AT MAXIMUM MATERIAL CONDITION, IN RELATION TO SEATING PLANE AND EACH OTHER.
2. DIMENSION L TO CENTER OF LEADS WHEN FORMED PARALLEL.
3. DIMENSION B DOES NOT INCLUDE MOLD FLASH.

DIM	MILLIMETERS		INCHES	
	MIN	MAX	MIN	MAX
A	31.37	32.13	1.235	1.265
B	13.72	14.22	0.540	0.560
C	3.94	5.08	0.155	0.200
D	0.36	0.56	0.014	0.022
F	1.02	1.52	0.040	0.060
G	2.54 BSC		0.100 BSC	
H	1.65	2.03	0.065	0.080
J	0.20	0.38	0.008	0.015
K	2.92	3.43	0.115	0.135
L	15.24 BSC		0.600 BSC	
M	0°	15°	0°	15°
N	0.51	1.02	0.020	0.040

## OUTLINE DIMENSIONS

### DW SUFFIX PLASTIC SOIC PACKAGE CASE 751E-04 ISSUE E

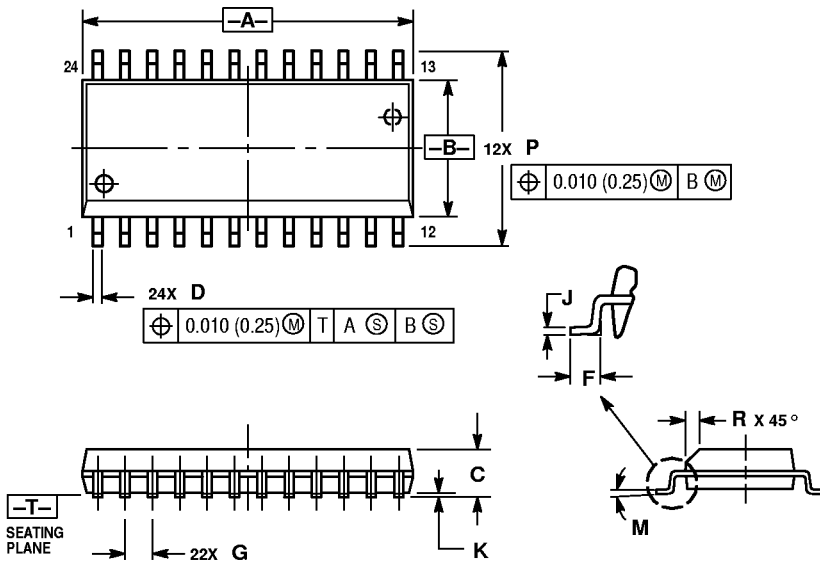

**NOTES:**

1. DIMENSIONING AND TOLERANCING PER ANSI Y14.5M, 1982.
2. CONTROLLING DIMENSION: MILLIMETER.
3. DIMENSIONS A AND B DO NOT INCLUDE MOLD PROTRUSION.
4. MAXIMUM MOLD PROTRUSION 0.15 (0.006) PER SIDE.
5. DIMENSION D DOES NOT INCLUDE DAMBAR PROTRUSION. ALLOWABLE DAMBAR PROTRUSION SHALL BE 0.13 (0.005) TOTAL IN EXCESS OF D DIMENSION AT MAXIMUM MATERIAL CONDITION.

DIM	MILLIMETERS		INCHES	
	MIN	MAX	MIN	MAX
A	15.25	15.54	0.601	0.612
B	7.40	7.60	0.292	0.299
C	2.35	2.65	0.093	0.104
D	0.35	0.49	0.014	0.019
F	0.41	0.90	0.016	0.035
G	1.27 BSC		0.050 BSC	
J	0.23	0.32	0.009	0.013
K	0.13	0.29	0.005	0.011
M	0° - 8°		0° - 8°	
P	10.05	10.55	0.395	0.415
R	0.25	0.75	0.010	0.029

Motorola reserves the right to make changes without further notice to any products herein. Motorola makes no warranty, representation or guarantee regarding the suitability of its products for any particular purpose, nor does Motorola assume any liability arising out of the application or use of any product or circuit, and specifically disclaims any and all liability, including without limitation consequential or incidental damages. "Typical" parameters which may be provided in Motorola data sheets and/or specifications can and do vary in different applications and actual performance may vary over time. All operating parameters, including "Typicals" must be validated for each customer application by customer's technical experts. Motorola does not convey any license under its patent rights nor the rights of others. Motorola products are not designed, intended, or authorized for use as components in systems intended for surgical implant into the body, or other applications intended to support or sustain life, or for any other application in which the failure of the Motorola product could create a situation where personal injury or death may occur. Should Buyer purchase or use Motorola products for any such unintended or unauthorized application, Buyer shall indemnify and hold Motorola and its officers, employees, subsidiaries, affiliates, and distributors harmless against all claims, costs, damages, and expenses, and reasonable attorney fees arising out of, directly or indirectly, any claim of personal injury or death associated with such unintended or unauthorized use, even if such claim alleges that Motorola was negligent regarding the design or manufacture of the part. Motorola and  are registered trademarks of Motorola, Inc. Motorola, Inc. is an Equal Opportunity/Affirmative Action Employer.

**How to reach us:**

**USA/EUROPE/Locations Not Listed:** Motorola Literature Distribution;  
P.O. Box 20912; Phoenix, Arizona 85036. 1-800-441-2447 or 602-303-5454

**MFAX:** RMFAX0@email.sps.mot.com - TOUCHTONE 602-244-6609  
**INTERNET:** http://Design-NET.com

**JAPAN:** Nippon Motorola Ltd.; Tatsumi-SPD-JLDC, 6F Seibu-Butsuryu-Center,  
3-14-2 Tatsumi Koto-Ku, Tokyo 135, Japan. 03-81-3521-8315

**ASIA/PACIFIC:** Motorola Semiconductors H.K. Ltd.; 8B Tai Ping Industrial Park,  
51 Ting Kok Road, Tai Po, N.T., Hong Kong. 852-26629298



MC14508B/D

