



MM54HC4002/MM74HC4002 Dual 4-Input NOR Gate

General Description

These NOR gates utilize advanced silicon-gate CMOS technology to achieve operating speeds similar to LS-TTL gates with the low power consumption of standard CMOS integrated circuits. All gates have buffered outputs, providing high noise immunity and the ability to drive 10 LS-TTL loads. The 54HC/74HC logic family is functionally as well as pin-out compatible with the standard 54LS/74LS logic family. The 54HC4002/74HC4002 is functionally equivalent and pin-out compatible with the CD4002B. All inputs are protected from damage due to static discharge by internal diode clamps to V_{CC} and ground.

Features

- Typical propagation delay: 8 ns
- Wide power supply range: 2V–6V
- Low quiescent current: 20 μ A maximum (74HC Series)
- Low input current: 1 μ A maximum
- Fanout of 10 LS-TTL loads

Connection Diagram

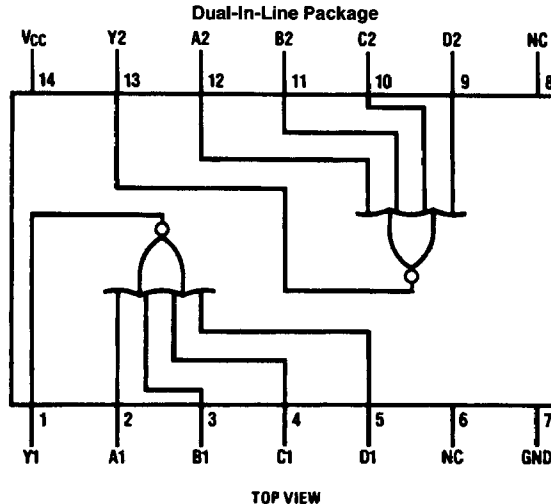

$$Y = \overline{A + B + C + D}$$

TL/F/5154-1

Order Number MM54HC4002* or MM74HC4002*

*Please look into Section 8, Appendix D for availability of various package types.

Absolute Maximum Ratings (Notes 1 & 2)

If Military/Aerospace specified devices are required, contact the National Semiconductor Sales Office/Distributors for availability and specifications.

Supply Voltage (V_{CC})	-0.5 to +7.0V
DC Input Voltage (V_{IN})	-1.5 to $V_{CC} + 1.5V$
DC Output Voltage (V_{OUT})	-0.5 to $V_{CC} + 0.5V$
Clamp Diode Current (I_{IK}, I_{OK})	± 20 mA
DC Output Current, per pin (I_{OUT})	± 25 mA
DC V_{CC} or GND Current, per pin (I_{CC})	± 50 mA
Storage Temperature Range (T_{STG})	-65°C to +150°C
Power Dissipation (P_D)	
(Note 3)	600 mW
S.O. Package only	500 mW
Lead Temp. (T_L) (Soldering 10 seconds)	260°C

Operating Conditions

	Min	Max	Units
Supply Voltage (V_{CC})	2	6	V
DC Input or Output Voltage (V_{IN}, V_{OUT})	0	V_{CC}	V
Operating Temp. Range (T_A)			
MM74HC	-40	+85	°C
MM54HC	-55	+125	°C
Input Rise or Fall Times (t_r, t_f)			
$V_{CC} = 2.0V$		1000	ns
$V_{CC} = 4.5V$		500	ns
$V_{CC} = 6.0V$		400	ns

DC Electrical Characteristics (Note 4)

Symbol	Parameter	Conditions	V_{CC}	$T_A = 25^\circ C$		74HC $T_A = -40$ to $85^\circ C$		54HC $T_A = -55$ to $125^\circ C$		Units	
				Typ	Guaranteed Limits						
V_{IH}	Minimum High Level Input Voltage		2.0V		1.5	1.5	1.5		V		
			4.5V		3.15	3.15	3.15		V		
			6.0V		4.2	4.2	4.2		V		
V_{IL}	Maximum Low Level Input Voltage**		2.0V		0.5	0.5	0.5		V		
			4.5V		1.35	1.35	1.35		V		
			6.0V		1.8	1.8	1.8		V		
V_{OH}	Minimum High Level Output Voltage	$V_{IN} = V_{IH}$ or V_{IL} $ I_{OUT} \leq 20 \mu A$	2.0V	2.0	1.9	1.9	1.9		V		
			4.5V	4.5	4.4	4.4	4.4		V		
			6.0V	6.0	5.9	5.9	5.9		V		
		$V_{IN} = V_{IH}$ or V_{IL} $ I_{OUT} \leq 4.0$ mA $ I_{OUT} \leq 5.2$ mA	4.5V	4.2	3.98	3.84	3.7		V		
			6.0V	5.7	5.48	5.34	5.2		V		
V_{OL}	Maximum Low Level Output Voltage	$V_{IN} = V_{IH}$ or V_{IL} $ I_{OUT} \leq 20 \mu A$	2.0V	0	0.1	0.1	0.1		V		
			4.5V	0	0.1	0.1	0.1		V		
			6.0V	0	0.1	0.1	0.1		V		
		$V_{IN} = V_{IH}$ or V_{IL} $ I_{OUT} \leq 4$ mA $ I_{OUT} \leq 5.2$ mA	4.5V	0.2	0.26	0.33	0.4		V		
			6.0V	0.2	0.26	0.33	0.4		V		
I_{IN}	Maximum Input Current	$V_{IN} = V_{CC}$ or GND	6.0V		± 0.1	± 1.0	± 1.0	μA			
I_{CC}	Maximum Quiescent Supply Current	$V_{IN} = V_{CC}$ or GND $I_{OUT} = 0 \mu A$	6.0		2.0	20	40	μA			

Note 1: Absolute Maximum Ratings are those values beyond which damage to the device may occur.

Note 2: Unless otherwise specified all voltages are referenced to ground.

Note 3: Power Dissipation temperature derating — plastic "N" package: -12 mW/°C from 65°C to 85°C; ceramic "J" package: -12 mW/°C from 100°C to 125°C.

Note 4: For a power supply of 5V $\pm 10\%$ the worst case output voltages (V_{OH} , and V_{OL}) occur for HC at 4.5V. Thus the 4.5V values should be used when designing with this supply. Worst case V_{IH} and V_{IL} occur at $V_{CC} = 5.5V$ and 4.5V respectively. (The V_{IH} value at 5.5V is 3.85V.) The worst case leakage current (I_{IN} , I_{CC} , and I_{OZ}) occur for CMOS at the higher voltage and so the 6.0V values should be used.

** V_{IL} limits are currently tested at 20% of V_{CC} . The above V_{IL} specification (30% of V_{CC}) will be implemented no later than Q1, CY'89.

AC Electrical Characteristics $V_{CC}=5V$, $T_A=25^\circ C$, $C_L=15\text{ pF}$, $t_r=t_f=6\text{ ns}$

Symbol	Parameter	Conditions	Typ	Guaranteed Limit	Units
t_{PHL} , t_{PLH}	Maximum Propagation Delay		11	20	ns

AC Electrical Characteristics $V_{CC}=2.0V$ to $6.0V$, $C_L=50\text{ pF}$, $t_r=t_f=6\text{ ns}$

Symbol	Parameter	Conditions	V_{CC}	$T_A=25^\circ C$		74HC	54HC	Units
				Typ		$T_A=-40\text{ to }85^\circ C$	$T_A=-55\text{ to }125^\circ C$	
t_{PHL} , t_{PLH}	Maximum Propagation Delay		2.0V	40	120	151	179	ns
			4.5V	12	24	30	36	ns
			6.0V	10	20	26	30	ns
t_{TLH} , t_{THL}	Maximum Output Rise and Fall Time		2.0V	30	75	95	110	ns
			4.5V	10	15	19	22	ns
			6.0V	9	13	16	19	ns
C_{PD}	Power Dissipation Capacitance (Note 5)	(per gate)		25				pF
C_{IN}	Maximum Input Capacitance			5	10	10	10	pF

Note 5: C_{PD} determines the no load dynamic power consumption, $P_D = C_{PD} V_{CC}^2 f + I_{CC} V_{CC}$, and the no load dynamic current consumption, $I_S = C_{PD} V_{CC} f + I_{CC}$.