



OCTAL D-TYPE FLIP-FLOP WITH 3-STATE OUTPUTS

The MC74F574 is a high-speed, low-power octal D-type flip-flop featuring separate D-type inputs for each flip-flop and 3-state outputs for bus oriented applications. A buffered clock (CP) and Output Enable (\overline{OE}) are common to all flip-flops.

This device is functionally identical to the F374 except for the pinouts.

- Broadside Pinout Version of F374
- Edge-Triggered D-Type Inputs
- Buffered Positive Edge-Triggered Clock
- 3-State Outputs for Bus Oriented Applications
- ESD Protection > 4000 Volts

PIN ASSIGNMENT

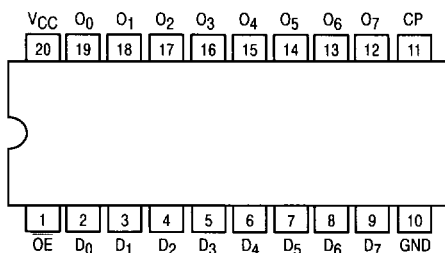

LOGIC SYMBOL

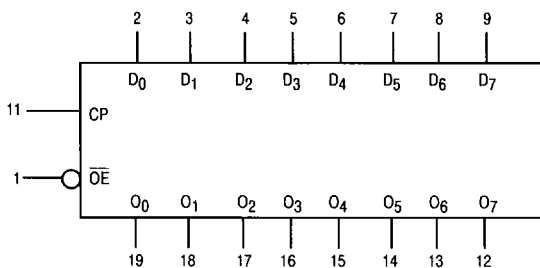

MC74F574

OCTAL D-TYPE FLIP-FLOP WITH 3-STATE OUTPUTS

FAST™ SCHOTTKY TTL

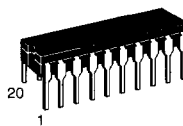

J SUFFIX
CERAMIC
CASE 732-03

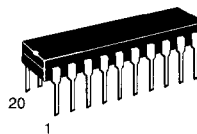

N SUFFIX
PLASTIC
CASE 738-03

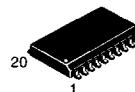

DW SUFFIX
SOIC
CASE 751D-03

ORDERING INFORMATION

MC74FXXXJ Ceramic
MC74FXXXN Plastic
MC74FXXXDW SOIC

GUARANTEED OPERATING RANGES

Symbol	Parameter	Min	Typ	Max	Unit	
V _{CC}	DC Supply Voltage	74	4.5	5.0	5.5	V
T _A	Operating Ambient Temperature Range	74	0	25	70	°C
I _{OH}	Output Current — High	74	—	—	3.0	mA
I _{OL}	Output Current — Low	74	—	—	24	mA

MC74F574

FUNCTION TABLE

Inputs			Internal Register	Outputs	Operating Mode
OE	CP	D _n		Q ₀ -Q ₇	
L L	↑ ↑	l h	L H	L H	Load and read register
L	‡	X	NC	NC	Hold
H H	↑ X	D _n X	D _n X	Z Z	Disable outputs

H = HIGH voltage level
h = HIGH voltage level one set-up time prior to the Low-to-High clock transition
L = LOW voltage level
l = LOW voltage level one set-up time prior to the Low-to-High clock transition
NC = No change
X = Don't care
Z = High impedance "off" state
↑ = Low-to-High clock transition
‡ = Not a Low-to-High clock transition

FUNCTIONAL DESCRIPTION

The MC74F574 consists of eight edge-triggered flip-flops with individual D-type inputs and 3-state true outputs. The buffered clock and buffered Output Enable are common to all flip-flops. The eight flip-flops will store the state of their individual D inputs that meet the setup and hold times requirements

on the LOW-to-HIGH Clock (CP) transition. With the Output Enable (OE) LOW, the contents of the eight flip-flops are available at the outputs. When the OE is HIGH, the outputs go to the high impedance state. Operation of the OE input does not affect the state of the flip-flops.

4

DC CHARACTERISTICS OVER OPERATING TEMPERATURE RANGE (unless otherwise specified)

Symbol	Parameter	Limits			Unit	Test Conditions (Note 1)	
		Min	Typ	Max			
V _{IH}	Input HIGH Voltage	2.0	—	—	V	Guaranteed Input HIGH Voltage	
V _{IL}	Input LOW Voltage	—	—	0.8	V	Guaranteed Input LOW Voltage	
V _{IK}	Input Clamp Diode Voltage	—	—	-1.2	V	V _{CC} = MIN, I _{IN} = -18 mA	
V _{OH}	Output HIGH Voltage	2.4	—	—	V	I _{OH} = -3.0 mA	V _{CC} = MIN
		2.7	—	—	V		V _{CC} = 4.75 V
V _{OL}	Output LOW Voltage	—	—	0.5	V	I _{OL} = 24 mA	V _{CC} = MIN
I _{IH}	Input HIGH Current	—	—	20	μA	V _{CC} = MAX, V _{IN} = 2.7 V	
		—	—	100		V _{CC} = MAX, V _{IN} = 7.0 V	
I _{IL}	Input LOW Current	—	—	-0.6	mA	V _{CC} = MAX, V _{IN} = 0.5 V	
I _{OZH}	Output Off Current — HIGH	—	—	50	μA	V _{CC} = MAX, V _{OUT} = 2.7 V	
I _{OZL}	Output Off Current — LOW	—	—	-50	μA	V _{CC} = MAX, V _{OUT} = 0.5 V	
I _{OS}	Output Short Circuit Current (Note 2)	-60	—	-150	mA	V _{CC} = MAX, V _{OUT} = 0 V	
I _{CCZ}	Power Supply Current (All Outputs OFF)	—	55	86	mA	V _{CC} = MAX	D _n - GND; OE = 4.5 V

NOTES:

- For conditions shown as MIN or MAX, use the appropriate value specified under recommended operating conditions for the applicable device type.
- Not more than one output should be shorted at a time, nor for more than 1 second.

MC74F574

LOGIC DIAGRAM

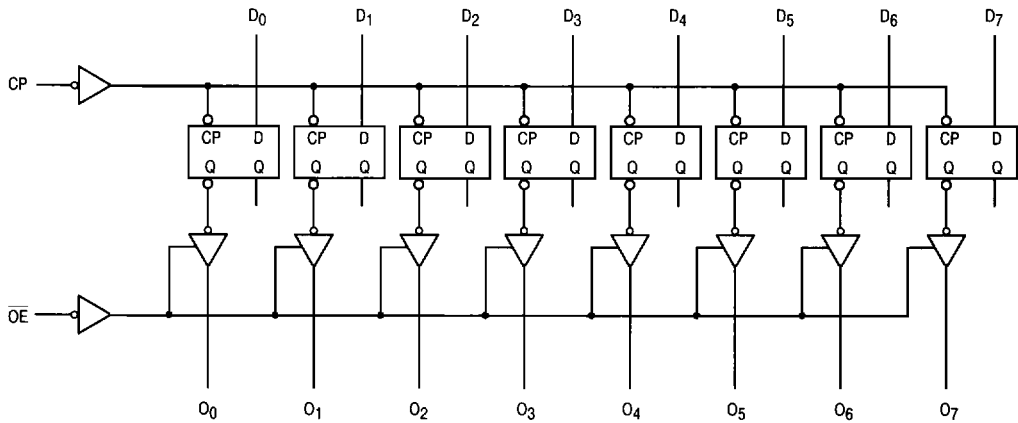

AC ELECTRICAL CHARACTERISTICS

Symbol	Parameter	54/74F			74F		Unit
		$T_A = +25^\circ\text{C}$ $V_{CC} = +5.0\text{ V}$ $C_L = 50\text{ pF}$			$T_A = 0^\circ\text{C to } +70^\circ\text{C}$ $V_{CC} = +5.0\text{ V } \pm 10\%$ $C_L = 50\text{ pF}$		
		Min	Typ	Max	Min	Max	
f_{MAX}	Maximum Clock Frequency	100	—	—	70	—	MHz
t_{PLH} t_{PHL}	Propagation Delay CP to O_n	2.5	—	8.5	2.5	8.5	ns
t_{PZH} t_{PZL}	Output Enable Time	3.0	—	9.0	2.5	10.0	ns
t_{PHZ} t_{PLZ}	Output Disable Time	1.5	—	5.5	1.5	6.5	ns

AC OPERATING CHARACTERISTICS

Symbol	Parameter	54/74F			74F			Unit
		$T_A = +25^\circ\text{C}$ $V_{CC} = +5.0\text{ V}$ $C_L = 50\text{ pF}$			$T_A = 0^\circ\text{C to } +70^\circ\text{C}$ $V_{CC} = +5.0\text{ V } \pm 10\%$ $C_L = 50\text{ pF}$			
		Min	Typ	Max	Min	Typ	Max	
$t_{s(H)}$ $t_{s(L)}$	Setup Time, HIGH or LOW D_n to CP	2.5	—	—	2.5	—	—	ns
$t_{h(H)}$ $t_{h(L)}$	Hold Time, HIGH to LOW D_n to CP	2.0	—	—	2.0	—	—	ns
$t_{w(H)}$ $t_{w(L)}$	CP Pulse Width HIGH or LOW	5.0	—	—	5.0	—	—	ns

4