

Document No.	853-0328
ECN No.	94536
Date of issue	September 19, 1988
Status	Product Specification
FAST Products	

# FAST 74F08 Gate

## Quad Two-Input AND Gate

### FUNCTION TABLE

INPUTS		OUTPUT
D <sub>na</sub>	D <sub>nb</sub>	Q <sub>n</sub>
L	L	L
L	H	L
H	L	L
H	H	H

H = High voltage level  
L = Low voltage level

### LOGIC DIAGRAM

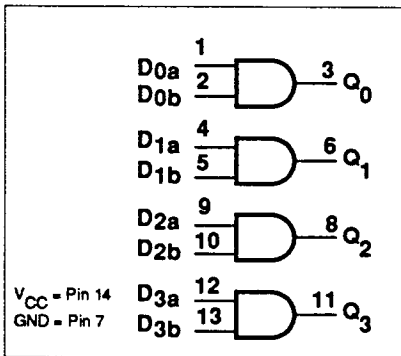

TYPE	TYPICAL PROPAGATION DELAY	TYPICAL SUPPLY CURRENT (TOTAL)
74F08	4.1 ns	7.1 mA

### ORDERING INFORMATION

PACKAGES	COMMERCIAL RANGE $V_{CC} = 5V \pm 10\%$ ; $T_A = 0^\circ C$ to $+70^\circ C$
14-Pin Plastic DIP	N74F08N
14-Pin Plastic SO	N74F08D

### INPUT AND OUTPUT LOADING AND FAN-OUT TABLE

PINS	DESCRIPTION	74F(U.L.) HIGH/LOW	LOAD VALUE HIGH/LOW
D <sub>na</sub> , D <sub>nb</sub>	Data inputs	1.0/1.0	20µA/0.6mA
Q <sub>n</sub>	Data output	50/33	1.0mA/20mA

**NOTE:**

One (1.0) FAST Unit Load is defined as: 20µA in the High state and 0.6mA in the Low state.

### PIN CONFIGURATION

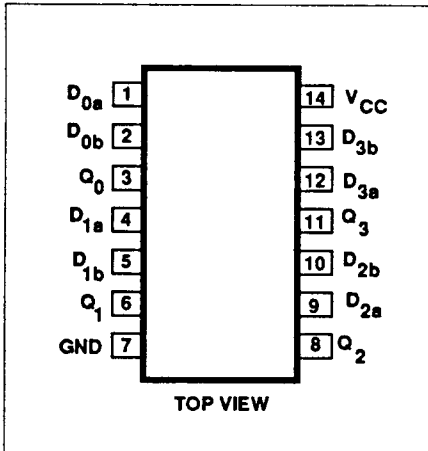

### LOGIC SYMBOL

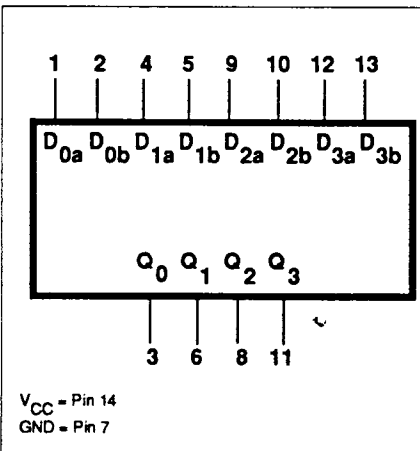

### LOGIC SYMBOL (IEEE/IEC)

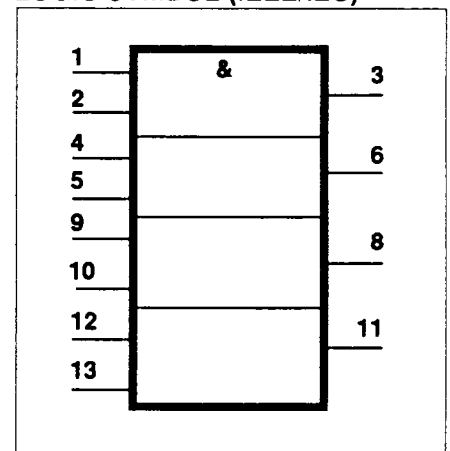

## Gate

## FAST 74F08

**ABSOLUTE MAXIMUM RATINGS** (Operation beyond the limits set forth in this table may impair the useful life of the device. Unless otherwise noted these limits are over the operating free-air temperature range.)

SYMBOL	PARAMETER	RATING	UNIT
$V_{CC}$	Supply voltage	-0.5 to +7.0	V
$V_{IN}$	Input voltage	-0.5 to +7.0	V
$I_{IN}$	Input current	-30 to +5	mA
$V_{OUT}$	Voltage applied to output in High output state	-0.5 to $V_{CC}$	V
$I_{OUT}$	Current applied to output in Low output state	40	mA
$T_A$	Operating free-air temperature range	0 to +70	°C
$T_{STG}$	Storage temperature	-65 to +150	°C

**RECOMMENDED OPERATING CONDITIONS**

SYMBOL	PARAMETER	LIMITS			UNIT
		Min	Nom	Max	
$V_{CC}$	Supply voltage	4.5	5.0	5.5	V
$V_{IH}$	High-level input voltage	2.0			V
$V_{IL}$	Low-level input voltage			0.8	V
$I_{IK}$	Input clamp current			-18	mA
$I_{OH}$	High-level output current			-1	mA
$I_{OL}$	Low-level output current			20	mA
$T_A$	Operating free-air temperature range	0		70	°C

**DC ELECTRICAL CHARACTERISTICS** (Over recommended operating free-air temperature range unless otherwise noted.)

SYMBOL	PARAMETER	TEST CONDITIONS <sup>1</sup>	LIMITS			UNIT	
			Min	Typ <sup>2</sup>	Max		
$V_{OH}$	High-level output voltage	$V_{CC} = \text{MIN}, V_{IL} = \text{MAX}$	$\pm 10\%V_{CC}$	2.5		V	
		$V_{IH} = \text{MIN}, I_{OH} = \text{MAX}$	$\pm 5\%V_{CC}$	2.7	3.4	V	
$V_{OL}$	Low-level output voltage	$V_{CC} = \text{MIN}, V_{IL} = \text{MAX}$	$\pm 10\%V_{CC}$		0.30	0.50	V
		$V_{IH} = \text{MIN}, I_{OL} = \text{MAX}$	$\pm 5\%V_{CC}$		0.30	0.50	V
$V_{IK}$	Input clamp voltage	$V_{CC} = \text{MIN}, I_I = I_{IK}$			-0.73	-1.2	V
$I_I$	Input current at maximum input voltage	$V_{CC} = \text{MAX}, V_I = 7.0V$				100	$\mu A$
$I_{IH}$	High-level input current	$V_{CC} = \text{MAX}, V_I = 2.7V$				20	$\mu A$
$I_{IL}$	Low-level input current	$V_{CC} = \text{MAX}, V_I = 0.5V$				-0.6	mA
$I_{OS}$	Short circuit output current <sup>3</sup>	$V_{CC} = \text{MAX}$		-60		-150	mA
$I_{CC}$	Supply current (total)	$I_{CCH}$	$V_{CC} = \text{MAX}$	$V_{IN} = 4.5V$	5.5	8.3	mA
		$I_{CCL}$		$V_{IN} = \text{GND}$	8.6	12.9	mA

**NOTES:**

- For conditions shown as MIN or MAX, use the appropriate value specified under recommended operating conditions for the applicable type.
- All typical values are at  $V_{CC} = 5V, T_A = 25^\circ C$ .
- Not more than one output should be shorted at a time. For testing  $I_{OS}$ , the use of high-speed test apparatus and/or sample-and-hold techniques are preferable in order to minimize internal heating and more accurately reflect operational values. Otherwise, prolonged shorting of a High output may raise the chip temperature well above normal and thereby cause invalid readings in other parameter tests. In any sequence of parameter tests,  $I_{OS}$  tests should be performed last.

Gate

FAST 74F08

AC ELECTRICAL CHARACTERISTICS

SYMBOL	PARAMETER	TEST CONDITION	LIMITS					UNIT
			T <sub>a</sub> = +25°C V <sub>CC</sub> = 5V C <sub>L</sub> = 50pF R <sub>L</sub> = 500Ω			T <sub>a</sub> = 0°C to +70°C V <sub>CC</sub> = 5V ±10% C <sub>L</sub> = 50pF R <sub>L</sub> = 500Ω		
			Min	Typ	Max	Min	Max	
t <sub>PLH</sub> t <sub>PHL</sub>	Propagation delay D <sub>na</sub> , D <sub>nb</sub> to Q <sub>n</sub>	Waveform 1	3.0 2.5	4.2 4.0	5.6 5.3	3.0 2.5	6.6 6.3	ns

AC WAVEFORMS

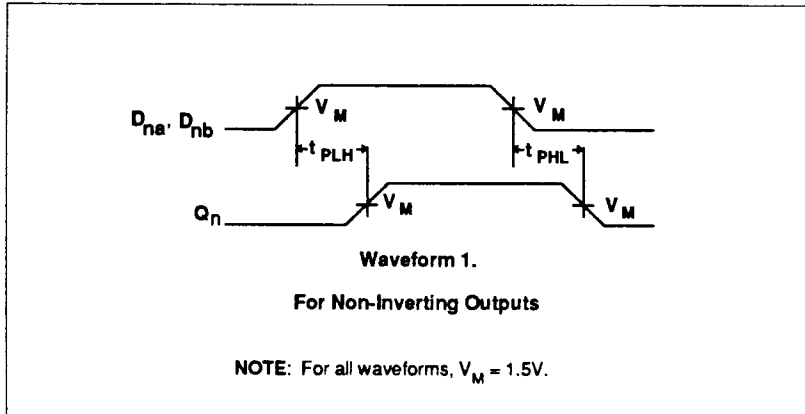

TEST CIRCUIT AND WAVEFORMS

**Test Circuit For Totem-Pole Outputs**

**DEFINITIONS**  
 R<sub>L</sub> = Load resistor; see AC CHARACTERISTICS for value.  
 C<sub>L</sub> = Load capacitance includes jig and probe capacitance; see AC CHARACTERISTICS for value.  
 R<sub>T</sub> = Termination resistance should be equal to Z<sub>OUT</sub> of pulse generators.

**V<sub>M</sub> = 1.5V**  
**Input Pulse Definition**

FAMILY	INPUT PULSE REQUIREMENTS				
	Amplitude	Rep. Rate	t <sub>w</sub>	t <sub>TLH</sub> (t <sub>p</sub> )	t <sub>THL</sub> (t <sub>p</sub> )
74F	3.0V	1MHz	500ns	2.5ns	2.5ns

## VI. COMMERCIAL PRODUCT SPECIAL PROCESSING T-90-20

### SUPR II LEVEL B PRICING ADDERS

#### SUPR II LEVEL B

Signetics Upgraded Product Reliability (SUPR) program is designed to provide customers whose systems require an infant mortality level less than that of our non-burned-in products (which is typically below 1000 PPM).

#### DEVICE AVAILABILITY

Products available for Level B processing are identified in the Price Book with a "B" suffix to the basic part number.

PRODUCT FAMILY	SUGGESTED RESALE ADDERS		
	1-99	100-999	OVER 1000
LIN	.14	.14	.11
LOG (TTL)			
(SSI)	.12	.10	.08
(MSI)	.16	.14	.11
(OCT)	.16	.14	.11
(CTM)	.16	.14	.11
LOG (ECL)			
(SSI)	.25	.23	.20
(MSI)	.25	.23	.20
LOG (LSI)	Consult Factory for Pricing		
(RAM)			
MIC (8X)	Consult Factory for Pricing		
PLD			
MCG	Consult Factory for Pricing		
DAT	Not Available		
MIC			

#### MARKING FORMAT EXAMPLES

Standard (no Burn-In) Products (Dual-in-line)



SUPR II (Burned-In) Products (Dual-in-line)

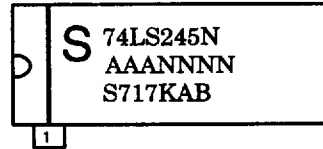

**NOTE:** The "B" in the 7<sup>th</sup> position on the 3<sup>rd</sup> line, when present, is the SUPR II Burn-In indicator.

#### TAPE AND REEL PACKAGING

#### SPECIFICATIONS

Tape and Reel specifications conform to Electronic Industries Association (EIA) Proposed Specification #EIA-481-A using 13 inch reels. Current incremental quantities reflect the quantities per reel. As more customers are able to handle a larger quantity per reel, this quantity will be increased.

#### DEVICE AVAILABILITY

Products available in tape and reel packaging are identified in the Price Book with a "T" suffix to the basic part number and are only offered as a product for sale by the reel. Return of product is limited to full reels with unbroken quality seals.

#### TAPE AND REEL PRICING ADDERS

PRODUCT FAMILY	SUGGESTED RESALE ADDER
MCG	.07
LIN	.07
LOG	.07
DAT	PACKAGE A28 = .20 A44 = .25 A52 = .30 A68 = .40 A84 = .45 D24 = .17
MIC	

**VII. PACKING QUANTITY INFORMATION**

T-90-20

**CERAMIC DUAL IN-LINE (CERDIP)**

PACKAGE CODE	PIN COUNT	QUANTITIES	
		DEVICES PER TUBE	DEVICES PER BOX
F/FE, BPA, PA	8-pin (300-mil)	48	1920
F, BCA, CA	14-pin (300-mil)	25	1000
F, BEA, EA	16-pin (300-mil)	25	1000
F, BVA, MVA	18-pin (300-mil)	21	840
F/FA, BRA, RA	20-pin (300-mil)	20	800
F, BWA, WA	22-pin (400-mil)	17	544
F/FA/F6, BJA, JA	24-pin (600-mil)	15	360
F/FA/F3/F24, BLA, LA	24-pin (300-mil)	15	600
F, BXA, XA	24-pin (400-mil)	15	480
F/FA/F28, BXA, XA	28-pin (600-mil)	13	312
FA	32-pin (600-mil)	11	264
F/FA/F40, BQA, MQA, QA	40-pin (600-mil)	9	216

**CERPAC**

PACKAGE CODE	PIN COUNT	QUANTITIES
		DEVICES PER TUBE
BDA/DAW	14-pin	145
BFA/FAW	16-pin	145
BXA/BYAW	18-pin	100
BSA/SAW/WB	20-pin	100
BKA/KAW	24-pin	120
BYA/YAW	28-pin	50

**CERQUAD**

PACKAGE CODE	PIN COUNT	QUANTITIES	
		DEVICES PER TRAY	DEVICES PER BOX
KA/K44	44-pin	6	6
KA/K68	68-pin	4	4
KA	84-pin	42	210

**LEADLESS CHIP CARRIER**

PACKAGE CODE	PIN COUNT	QUANTITIES
		DEVICES PER TUBE
B2A/2A/GA	20-pin	55
B3A/3A/GA/GC1	28-pin	43
YA/YA/GC2	32-pin	35
BUA/MXA/MUA/UA/XA/GA/GC	44-pin	27
BZA/BUA/UA/ZA/GA/GC	68-pin	19

QUANTITIES SHOWN IN GRAY REQUIRE PURCHASE TO BE MADE IN EXACT MULTIPLES OF THAT QUANTITY.

**VII. PACKING QUANTITY INFORMATION**

T-90-20

**PLASTIC DUAL IN-LINE**

PACKAGE CODE	PIN COUNT	QUANTITIES	
		DEVICES PER TUBE	DEVICES PER BOX
N/N8	8-pin (300-mil)	50	2000
N/N14/N16	14- 16-pin (300-mil)	25	1000
N	18-pin (300-mil)	20	800
N/N20	20-pin (300-mil)	18	720
N	22-pin (400-mil)	17	544
N/N6	24-pin (600-mil)	15	360
N/N3/N24	24-pin (300-mil)	15	600
N/N24	24-pin (400-mil)	15	480
N/N28	28-pin (600-mil)	13	312
N/N3	28-pin (300-mil)	13	520
N	32-pin (600-mil)	11	264
N/N40	40-pin (600-mil)	9	216
NB (Shrink)	42-pin (600-mil)	12	288
N/N48	48-pin (600-mil)	7	168
N	50-pin (900-mil)	7	112
N/N64	64-pin (900-mil)	5	80

**PLASTIC LEADED CHIP CARRIER (PLCC)**

PACKAGE CODE	PIN COUNT	QUANTITIES		
		DEVICES PER TUBE	DEVICES PER BOX	DEVICES PER REEL
A	20-pin	46	3680	1000
A/A28	28-pin	37	2368	750
A	32-pin	31	2232	750
A/A44	44-pin	26	1248	500
A/A52	52-pin	23	1012	500
A/A68	68-pin	18	648	250
A/A84	84-pin	15	420	250

QUANTITIES SHOWN IN GRAY REQUIRE PURCHASE TO BE MADE IN EXACT MULTIPLES OF THAT QUANTITY.

**VII. PACKING QUANTITY INFORMATION**

T-90-20

**PLASTIC SMALL OUTLINE (SO)**

PACKAGE CODE	PIN COUNT	QUANTITIES		
		DEVICES PER TUBE	DEVICES PER BOX	DEVICES PER REEL
D/D8	8-pin (150-mil)	100	10000	2500
D	8-pin (300-mil)	64	2560	1000 - 13" 700 - 7"
D/D14	14-pin (150-mil)	57	5700	2500
D	16-pin (150-mil)	50	5000	2500
D	16-pin (300-mil)	48	1920	1000
DK(SSOP)	20-pin (170-mil)	75	6750	2500
D	20-pin (300-mil)	38	1520	1000
D/D24	24-pin (300-mil)	32	1280	1000
D	28-pin (300-mil)	27	1080	1000
D	40-pin (VSO-40)	31	1240	1000 - 13" 300 - 7"
D	56-pin (VSO-56)	22	616	1000

**QUAD FLAT PACK\***

PACKAGE CODE	PIN COUNT	QUANTITIES	
		DEVICES PER TRAY	DEVICES PER BOX
B/B44	44-pin	50	500
B/B44	44-pin	96	480
B	52-pin	119	595
B	80-pin	86	330
B	100-pin	50	250
B	120-pin	24	120
B	120-pin (Philips source)	30	150

\* Quad Flat Pack parts require dry pack handling according to EIA Standard - 583. These parts are identified in part list section with DRY PACK in the Cross Ref Part No field.

QUANTITIES SHOWN IN GRAY REQUIRE PURCHASE TO BE MADE IN EXACT MULTIPLES OF THAT QUANTITY.