

Fast CMOS 16-Bit Latched Transceivers

Product Features

- Compatible with LCX™ and LVT™ families of products
- Supports 5V Tolerant Mixed Signal Mode Operation
 - Input can be 3V or 5V
 - Output can be 3V or connected to 5V bus
- Advanced Low Power CMOS Operation
- Excellent output drive capability:
Balanced drives (24mA sink and source)
- Pin compatible with industry standard double-density pinouts
- Low ground bounce outputs
- Hysteresis on all inputs
- Industrial operating temperature range: -40°C to +85°C
- Multiple center pins and distributed Vcc/GND pins minimize switching noise
- Packages available:
 - 56-pin 240 mil wide plastic TSSOP (A56)
 - 56-pin 300 mil wide plastic SSOP (V56)

Product Description

Pericom Semiconductor's PI74LPT series of logic circuits are produced using the Company's advanced 0.6 micron CMOS technology, achieving industry leading speed grades.

The PI74LPT16543 is 16-bit latched transceivers organized with two sets of eight D-type latches with separate input and output controls for each set. For data flow from A to B, for example, the A-to-B Enable (xCEAB) input must be LOW in order to enter data from xAx or to take data from xBx, as indicated in the Truth Table. With xCEAB LOW, a LOW signal makes the A-to-B latches transparent; a subsequent LOW-to-HIGH transition of the xLEAB signal puts the A latches in the storage mode and their outputs no longer change the A inputs. With xCEAB and xOEAB both LOW, the 3-state B output buffers are active and reflect the data present at the output of the A latches. Control of data from B to A is similar, but uses the xCEAB, xLEAB, and xOEAB inputs.

The PI74LPT16543 can be driven from either 3.3V or 5.0V devices allowing this device to be used as a translator in a mixed 3.3/5.0V system.

Logic Block Diagram

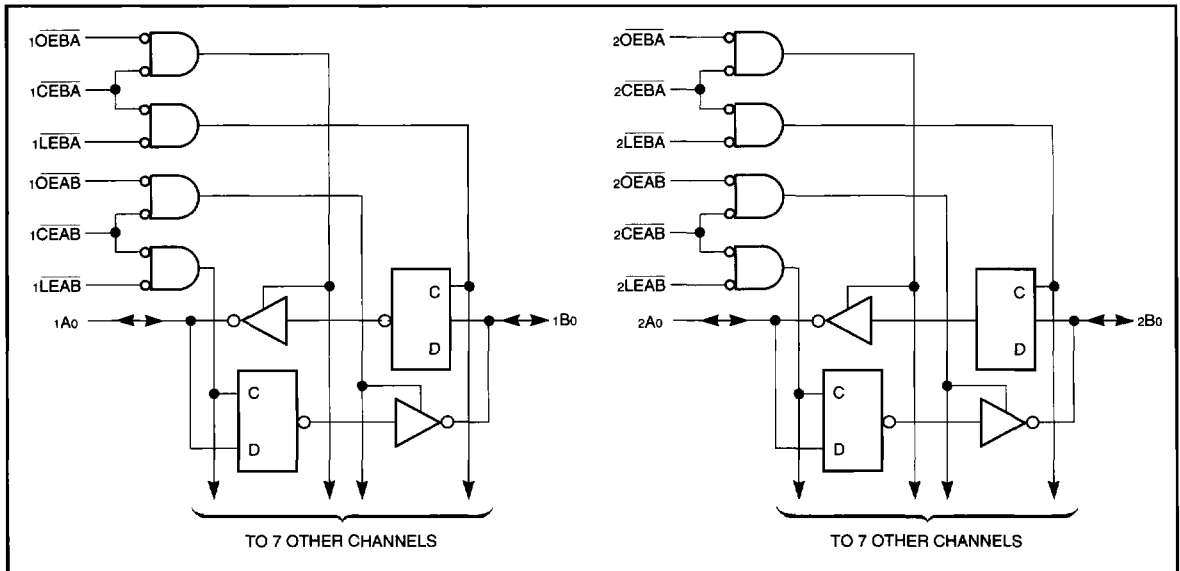

Product Pin Description

Pin Name	Description
xOEAB	A-to-B Output Enable Input (Active LOW)
xOEBA	B-to-A Output Enable Input (Active LOW)
xCEAB	A-to-B Enable Input (Active LOW)
xCEBA	B-to-A Enable Input (Active LOW)
xLEAB	A-to-B Latch Enable Input (Active LOW)
xLEBA	B-to-A Latch Enable Input (Active LOW)
xAx	A-to-B Data Inputs or B-to-A 3-State Outputs
xBx	B-to-A Data Inputs or B-to-A 3-State Outputs
GND	Ground
Vcc	Power

Truth Table⁽¹⁾

Inputs			Latch Status	Output Buffers
xCEAB	xLEAB	xOEAB	xAx TO xBx	xBx
H	X	X	Storing	High Z
X	H	X	Storing	X
X	X	H	X	High Z
L	L	L	Transparent	Current A Inputs
L	H	L	Storing	Previous* A Inputs

NOTES:

- *Before xLEAB LOW-to-HIGH Transition
H = High Voltage Level
L = Low Voltage Level
X = Don't Care or Irrelevant
Z = High Impedance
- A-to-B data flow shown. B-to-A flow control is the same, except using xCEBA, xLEBA, and xOEBA.

Product Pin Configuration

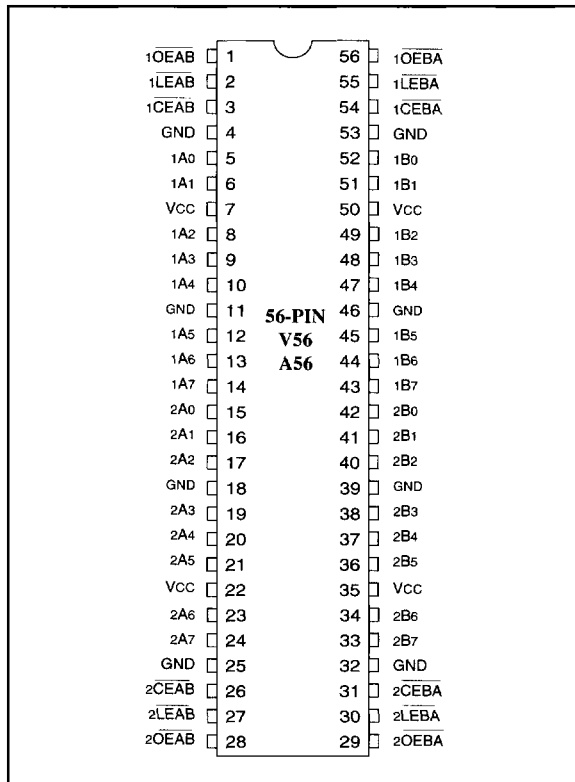

Maximum Ratings

(Above which the useful life may be impaired. For user guidelines, not tested.)

Storage Temperature	-65°C to +150°C
Ambient Temperature with Power Applied	-40°C to +85°C
Supply Voltage to Ground Potential (Inputs & Vcc Only)	-0.5V to +7.0V
Supply Voltage to Ground Potential (Outputs & D/O Only)	-0.5V to +7.0V
DC Input Voltage	-0.5V to +7.0V
DC Output Current	120 mA
Power Dissipation	1.0W

Note:

Stresses greater than those listed under MAXIMUM RATINGS may cause permanent damage to the device. This is a stress rating only and functional operation of the device at these or any other conditions above those indicated in the operational sections of this specification is not implied. Exposure to absolute maximum rating conditions for extended periods may affect reliability.

DC Electrical Characteristics (Over the Operating Range, TA = -40°C to +85°C, VCC = 2.7V to 3.6V)

Parameters	Description	Test Conditions ⁽¹⁾	Min.	Typ ⁽²⁾	Max.	Units
VIH	Input HIGH Voltage (Input pins)	Guaranteed Logic HIGH Level	2.2	—	5.5	V
	Input HIGH Voltage (I/O pins)		2.0	—	5.5	V
VIL	Input LOW Voltage (Input and I/O pins)	Guaranteed Logic LOW Level	-0.5	—	0.8	V
IIH	Input HIGH Current (Input pins)	VCC = Max., VIN = 5.5V	—	—	±1	µA
	Input HIGH Current (I/O pins)	VCC = Max., VIN = VCC	—	—	±1	µA
IIL	Input LOW Current (Input pins)	VCC = Max., VIN = GND	—	—	±1	µA
	Input LOW Current (I/O pins)	VCC = Max., VIN = GND	—	—	±1	µA
IOZH	High Impedance Output Current (3-State Output pins)	VCC = Max., VOUT = 5.5V	—	—	±1	µA
		VCC = Max., VOUT = GND	—	—	±1	µA
VIK	Clamp Diode Voltage	VCC = Min., IIN = -18 mA	—	-0.7	-1.2	V
IODH	Output HIGH Current	VCC = 3.3V, VIN = VIH or VIL, VO = 1.5V ⁽³⁾	-36	-60	-110	mA
IODL	Output LOW Current	VCC = 3.3V, VIN = VIH or VIL, VO = 1.5V ⁽³⁾	50	90	200	mA
VOH	Output HIGH Voltage	VCC = Min., IOH = -0.1 mA	VCC-0.2	—	—	V
		VIN = VIH or VIL, IOH = -3 mA	2.4	3.0	—	V
		VCC = 3.0V, IOH = -8 mA	2.4 ⁽⁵⁾	3.0	—	V
		VIN = VIH or VIL, IOH = -24 mA	2.0	—	—	V
VOL	Output LOW Voltage	VCC = Min., IOH = 0.1 mA	—	—	0.2	V
		VIN = VIH or VIL, IOH = 16 mA	—	0.2	0.4	V
		VIN = VIH or VIL, IOH = 24 mA	—	0.3	0.5	V
IOS	Short Circuit Current ⁽⁴⁾	VCC = Max. ⁽³⁾ , VOUT = GND	-60	-85	-240	mA
IOFF	Power Down Disable	VCC = 0V, VIN or VOUT ≤ 4.5V	—	—	±100	µA
VH	Input Hysteresis		—	150	—	mV

Notes:

- For Max. or Min. conditions, use appropriate value specified under Electrical Characteristics for the applicable device type.
- Typical values are at VCC = 3.3V, +25°C ambient and maximum loading.
- Not more than one output should be shorted at one time. Duration of the test should not exceed one second.
- This parameter is guaranteed but not tested.
- VOH = VCC - 0.6V at rated current.

Power Supply Characteristics

Parameters	Description	Test Conditions ⁽¹⁾		Min.	Typ ⁽²⁾	Max.	Units
I _{cc}	Quiescent Power Supply Current	V _{CC} = Max.	V _{IN} = GND or V _{CC}		0.1	10	μA
ΔI _{cc}	Quiescent Power Supply Current TTL Inputs HIGH	V _{CC} = Max.	V _{IN} = V _{CC} - 0.6V ⁽³⁾		2.0	30	μA
I _{CCD}	Dynamic Power Supply ⁽⁴⁾	V _{CC} = Max., Outputs Open xOE = GND One Bit Toggling 50% Duty Cycle	V _{IN} = V _{CC} V _{IN} = GND		50	75	μA/ MHz
I _c	Total Power Supply Current ⁽⁶⁾	V _{CC} = Max., Outputs Open f _i = 10 MHz 50% Duty Cycle xOE = GND One Bit Toggling	V _{IN} = V _{CC} - 0.6V V _{IN} = GND		0.6	2.3	mA
		V _{CC} = Max., Outputs Open f _i = 2.5 MHz 50% Duty Cycle xOE = GND 16 Bits Toggling	V _{IN} = V _{CC} - 0.6V V _{IN} = GND		2.1	4.7 ⁽⁵⁾	

Notes:

- For Max. or Min. conditions, use appropriate value specified under Electrical Characteristics for the applicable device.
- Typical values are at V_{CC} = 3.3V, +25°C ambient.
- Per TTL driven input; all other inputs at V_{CC} or GND.
- This parameter is not directly testable, but is derived for use in Total Power Supply Calculations.
- Values for these conditions are examples of the I_{cc} formula. These limits are guaranteed but not tested.
- I_C = I_{QUIESCENT} + I_{INPUTS} + I_{DYNAMIC}

$$I_c = I_{cc} + \Delta I_{cc} D_H N_T + I_{CCD} (f_{CP}/2 + f_i N_i)$$

I_{cc} = Quiescent Current (I_{CC1}, I_{CC2} and I_{CC3})

ΔI_{cc} = Power Supply Current for a TTL High Input

D_H = Duty Cycle for TTL Inputs High

N_T = Number of TTL Inputs at D_H

I_{CCD} = Dynamic Current Caused by an Input Transition Pair (HLH or LHL)

f_{CP} = Clock Frequency for Register Devices (Zero for Non-Register Devices)

N_{CP} = Number of Clock Inputs at f_{CP}

f_i = Input Frequency

N_i = Number of Inputs at f_i

All currents are in milliamps and all frequencies are in megahertz.

Switching Characteristics over Operating Range⁽¹⁾

Parameters	Description	Conditions ⁽²⁾	LPT16543		LPT16543A		LPT16543C		Unit
			Com.		Com.		Com.		
			Min ⁽³⁾	Max	Min ⁽³⁾	Max	Min ⁽³⁾	Max	
TP _{LH} TP _{HL}	Propagation Delay Transparent Mode xAX to xBx or xBx to xAx	C _L = 50 pF R _L = 500Ω	2.5	8.5	2.5	6.5	2.5	5.3	ns
TP _{LH} TP _{HL}	Propagation Delay xLEBA to xAx, xLEAB to xBx		2.5	12.5	2.5	8.0	2.5	7.0	ns
TP _{ZH} TP _{ZL}	Output Enable Time xOEBA or xOEAB to xAx or xBx		2.0	12.0	2.0	9.0	2.0	8.0	ns
TP _{HZ} TP _{LZ}	Output Disable Time ⁽⁴⁾ xOEBA or xOEAB to xAx or xBx		2.0	9.0	2.0	7.5	2.0	6.5	ns
TSU	Setup Time HIGH or LOW xAx or xBx to xLEAB or xLEBA		3.0	—	2.0	—	2.0	—	ns
TH	Hold Time HIGH or LOW xAx or xBx to xLEAB or xLEBA		2.0	—	2.0	—	2.0	—	ns
tw	xLEAB or xLEBA Pulse Width LOW		5.0	—	5.0	—	5.0	—	ns
tsk(o)	Output Skew ⁽⁵⁾		—	0.5	—	0.5	—	0.5	ns

Notes:

1. Propagation Delays and Enable/Disable times are with V_{CC} = 3.3V ±0.3V, normal range. For V_{CC} = 2.7V, extended range, all Propagation Delays and Enable/Disable times should be degraded by 20%.
2. See test circuit and wave forms.
3. Minimum limits are guaranteed but not tested on Propagation Delays.
4. This parameter is guaranteed but not production tested.
5. Skew between any two outputs, of the same package, switching in the same direction. This parameter is guaranteed by design.

Capacitance (T_A = 25°C, f = 1 MHz)

Parameters ⁽¹⁾	Description	Test Conditions	Typ	Max.	Units
C _{IN}	Input Capacitance	V _{IN} = 0V	4.5	6	pF
C _{OUT}	Output Capacitance	V _{OUT} = 0V	5.5	8	pF

Note:

1. This parameter is determined by device characterization but is not production tested.