

DATA SHEET

74LVC623A

Octal transceiver with dual enable
(3-State)

Product specification

1998 Jul 29

Octal transceiver with dual enable (3-State)

74LVC623A

FEATURES

- Wide supply voltage range of 1.2V to 3.6V
- In accordance with JEDEC standard no. 8-1A
- Flow-through pin-out architecture
- CMOS low power consumption
- Inputs accept voltages up to 5.5V
- Direct interface with TTL levels
- Output drive capability 50Ω transmission lines @ 85°C

DESCRIPTION

The 74LVC623A is a high performance, low-power, low-voltage Si-gate CMOS device, superior to most advanced CMOS compatible TTL families.

The 74LVC623A is an octal transceiver featuring non-inverting 3-State bus compatible outputs in both send and receive directions. This octal bus transceiver is designed for asynchronous two-way communication between data buses.

The control function implementation allows maximum flexibility in timing. This device allows data transmission from the A bus to the B bus or from the B bus to the A bus, depending upon the levels at the enable inputs (OEAB, OEBA). The enable inputs can be used to disable the device so that the buses are effectively isolated. The dual enable function configuration gives this transceiver the capability to store data by simultaneous enabling of OEAB and OEBA. Each output reinforces its input in this transceiver configuration. Thus, when both control inputs are enabled and all other data sources to the two sets of the bus lines are at high impedance OFF-state, both sets of bus lines will remain at their last states. The 8-bit codes appearing on the two sets of buses will be identical.

The '623A' is identical to the '620A' but has true (non-inverting) outputs.

QUICK REFERENCE DATA

GND = 0V; T_{amb} = 25°C; t_r = t_f ≤ 2.5 ns

SYMBOL	PARAMETER	CONDITIONS	TYPICAL	UNIT
t _{PHL} /t _{PLH}	Propagation delay An to Bn; Bn to An	C _L = 50pF V _{CC} = 3.3V	3.3	ns
C _I	Input capacitance		5.0	pF
C _{I/O}	Input/output capacitance		10	pF
C _{PD}	Power dissipation capacitance per latch	Notes 1, 2	32	pF

NOTES:

1. C_{PD} is used to determine the dynamic power dissipation (P_D in μW)
 $P_D = C_{PD} \times V_{CC}^2 \times f_i + \sum (C_L \times V_{CC}^2 \times f_o)$ where:
 f_i = input frequency in MHz; C_L = output load capacity in pF;
 f_o = output frequency in MHz; V_{CC} = supply voltage in V;
 $\sum (C_L \times V_{CC}^2 \times f_o)$ = sum of the outputs.
2. The condition is V_I = GND to V_{CC}.

ORDERING AND PACKAGE INFORMATION

PACKAGES	TEMPERATURE RANGE	OUTSIDE NORTH AMERICA	NORTH AMERICA	PKG. DWG. #
20-Pin Plastic SO	-40°C to +85°C	74LVC623A D	74LVC623A D	SOT163-1
20-Pin Plastic SSOP Type II	-40°C to +85°C	74LVC623A DB	74LVC623A DB	SOT339-1
20-Pin Plastic TSSOP Type I	-40°C to +85°C	74LVC623A PW	74LVC623APW DH	SOT360-1

Octal transceiver with dual enable (3-State)

74LVC623A

PIN CONFIGURATION

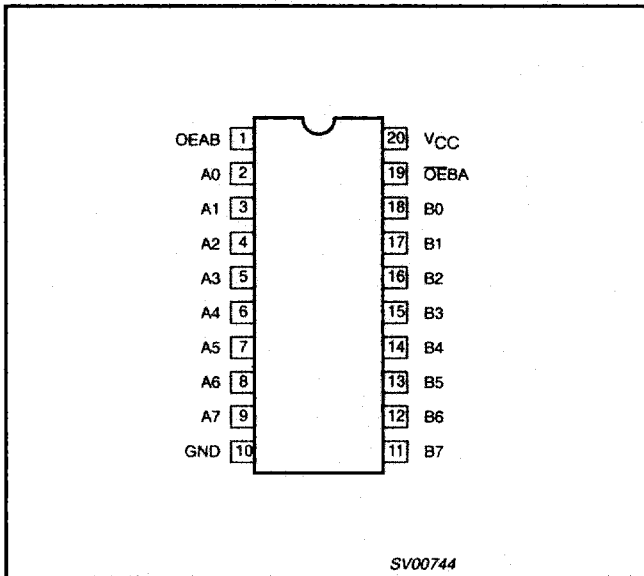

PIN DESCRIPTION

PIN NUMBER	SYMBOL	NAME AND FUNCTION
1	OEAB	Direction control
2, 3, 4, 5, 6, 7, 8, 9	A0 – A7	Data inputs/outputs
10	GND	Ground (0V)
18, 17, 16, 15, 14, 13, 12, 11	B0 – B7	Data inputs/outputs
19	OEBA	Output enable input (active LOW)
20	VCC	Positive supply voltage

LOGIC SYMBOL

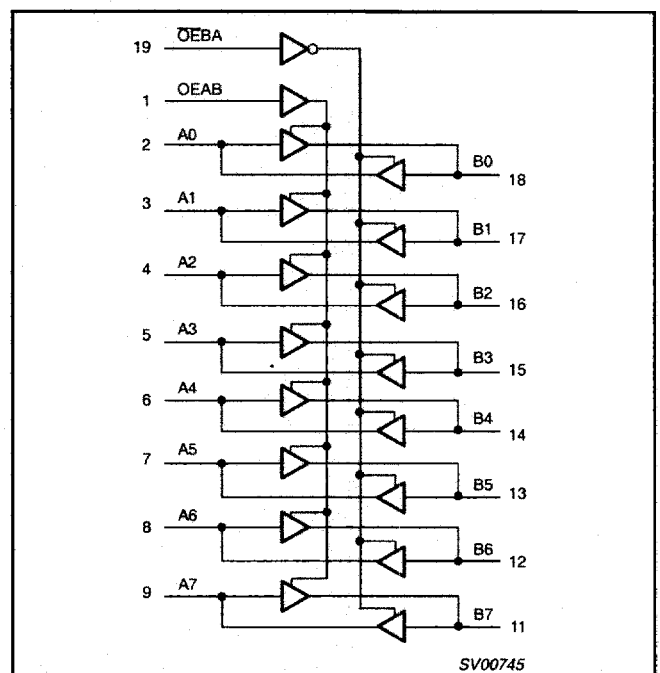

LOGIC SYMBOL (IEEE/IEC)

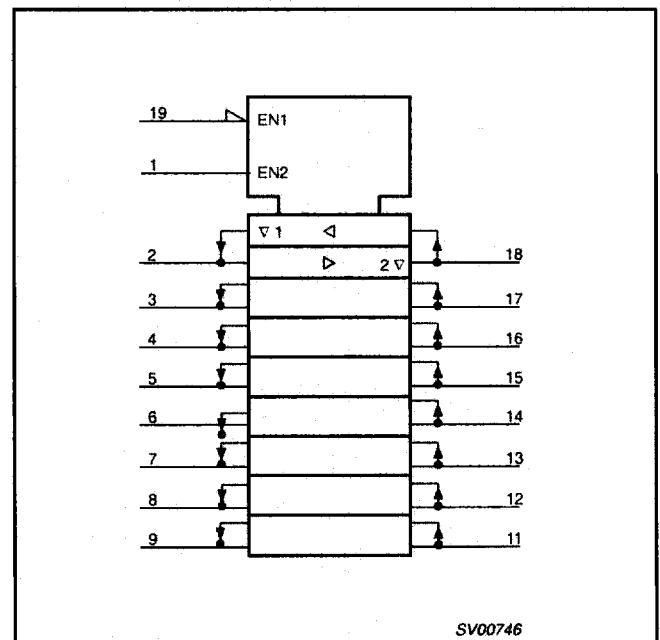

Octal transceiver with dual enable (3-State)

74LVC623A

FUNCTION TABLE

INPUTS		INPUTS/OUTPUT	
OEAB	OEBA	An	Bn
L	L	A=B	Inputs
H	H	Inputs	B=A
L	H	Z	Z
H	L	A=B Inputs	Inputs B=A

H = High voltage level
L = Low voltage level
Z = High impedance

RECOMMENDED OPERATING CONDITIONS

SYMBOL	PARAMETER	CONDITIONS	LIMITS		UNIT
			MIN	MAX	
V _{CC}	DC supply voltage (for max. speed performance)		2.7	3.6	V
V _{CC}	DC supply voltage (for low-voltage applications)		1.2	3.6	V
V _I	DC input voltage range		0	5.5	V
V _O	DC output voltage range; output HIGH or LOW state		0	V _{CC}	V
	DC output voltage range; output 3-State		0	5.5	
T _{amb}	Operating free-air temperature range		-40	+85	°C
t _r , t _f	Input rise and fall times	V _{CC} = 1.2 to 2.7V	0	20	ns/V
		V _{CC} = 2.7 to 3.6V	0	10	

ABSOLUTE MAXIMUM RATINGS¹

In accordance with the Absolute Maximum Rating System (IEC 134)
Voltages are referenced to GND (ground = 0V)

SYMBOL	PARAMETER	CONDITIONS	RATING	UNIT
V _{CC}	DC supply voltage		-0.5 to +6.5	V
I _{IK}	DC input diode current	V _I < 0	-50	mA
V _I	DC input voltage	Note 2	-0.5 to +6.5	V
I _{OK}	DC output diode current	V _O > V _{CC} or V _O < 0	± 50	mA
V _O	DC output voltage; output HIGH or LOW state	Note 2	-0.5 to V _{CC} +0.5	V
	DC output voltage; output 3-State	Note 2	-0.5 to 6.5	
I _O	DC output source or sink current	V _O = 0 to V _{CC}	± 50	mA
I _{GND} , I _{CC}	DC V _{CC} or GND current		± 100	mA
T _{stg}	Storage temperature range		-65 to +150	°C
P _{TOT}	Power dissipation per package			
	- plastic mini-pack (SO) - plastic shrink mini-pack (SSOP and TSSOP)	above +70°C derate linearly with 8 mW/K above +60°C derate linearly with 5.5 mW/K	500 500	mW

NOTES:

- Stresses beyond those listed may cause permanent damage to the device. These are stress ratings only and functional operation of the device at these or any other conditions beyond those indicated under "recommended operating conditions" is not implied. Exposure to absolute-maximum-rated conditions for extended periods may affect device reliability.
- The input and output voltage ratings may be exceeded if the input and output current ratings are observed.

Octal transceiver with dual enable (3-State)

74LVC623A

DC ELECTRICAL CHARACTERISTICS

Over recommended operating conditions voltages are referenced to GND (ground = 0V)

SYMBOL	PARAMETER	TEST CONDITIONS	LIMITS			UNIT
			Temp = -40°C to +85°C			
			MIN	TYP ¹	MAX	
V _{IH}	HIGH level input voltage	V _{CC} = 1.2V	V _{CC}			V
		V _{CC} = 2.7 to 3.6V	2.0			
V _{IL}	LOW level input voltage	V _{CC} = 1.2V			GND	V
		V _{CC} = 2.7 to 3.6V			0.8	
V _{OH}	HIGH level output voltage	V _{CC} = 2.7V; V _I = V _{IH} or V _{IL} ; I _O = -12mA	V _{CC} - 0.5			V
		V _{CC} = 3.0V; V _I = V _{IH} or V _{IL} ; I _O = -100µA	V _{CC} - 0.2	V _{CC}		
		V _{CC} = 3.0V; V _I = V _{IH} or V _{IL} ; I _O = -18mA	V _{CC} - 0.6			
		V _{CC} = 3.0V; V _I = V _{IH} or V _{IL} ; I _O = -24mA	V _{CC} - 0.8			
V _{OL}	LOW level output voltage	V _{CC} = 2.7V; V _I = V _{IH} or V _{IL} ; I _O = 12mA			0.40	V
		V _{CC} = 3.0V; V _I = V _{IH} or V _{IL} ; I _O = 100µA		GND	0.20	
		V _{CC} = 3.0V; V _I = V _{IH} or V _{IL} ; I _O = 24mA			0.55	
I _I	Input leakage current	V _{CC} = 3.6V; V _I = 5.5V or GND		±0.1	±5	µA
I _{OZ}	3-State output OFF-state current	V _{CC} = 3.6V; V _I = V _{IH} or V _{IL} ; V _O = 5.5V or GND		0.1	±5	µA
I _{off}	Power off leakage supply	V _{CC} = 0.0V; V _I or V _O = 5.5V		0.1	±10	µA
I _{CC}	Quiescent supply current	V _{CC} = 3.6V; V _I = V _{CC} or GND; I _O = 0		0.1	10	µA
ΔI _{CC}	Additional quiescent supply current per input pin	V _{CC} = 2.7V to 3.6V; V _I = V _{CC} - 0.6V; I _O = 0		5	500	µA

NOTES:1. All typical values are at V_{CC} = 3.3V and T_{amb} = 25°C.**AC CHARACTERISTICS**GND = 0 V; t_r = t_f ≤ 2.5 ns; C_L = 50 pF

SYMBOL	PARAMETER	WAVEFORM	LIMITS					UNIT
			V _{CC} = 3.3V ±0.3V			V _{CC} = 2.7V		
			MIN	TYP ¹	MAX	MIN	MAX	
t _{PHL} /t _{PLH}	Propagation delay An to Bn, Bn to An	Figures 1, 4	1.5	2.3	6	1.5	7	ns
t _{PZH} /t _{PZL}	3-State output enable time OEAB to Bn	Figures 3, 4	1.5	4.6	7.6	1.5	8.6	ns
t _{PHZ} /t _{PLZ}	3-State output disable time OEAB to Bn	Figures 3, 4	1.5	4.0	6.5	1.5	7.5	ns
t _{PZH} /t _{PZL}	3-State output enable time OEBA to An	Figures 2, 4	1.5	4.4	7.9	1.5	8.9	ns
t _{PHZ} /t _{PLZ}	3-State output disable time OEBA to An	Figures 2, 4	1.5	3.7	6.5	1.5	7.5	ns

NOTE:1. These typical values are at V_{CC} = 3.3V and T_{amb} = 25°C.

Octal transceiver with dual enable (3-State)

74LVC623A

AC WAVEFORMS

- $V_M = 1.5V$ at $V_{CC} \geq 2.7V$
- $V_M = 0.5V \cdot V_{CC}$ at $V_{CC} < 2.7V$
- V_{OL} and V_{OH} are the typical output voltage drop that occur with the output load.
- $V_X = V_{OL}$ at $0.3V \geq 2.7V$
- $V_X = V_{OL} + 0.1V_{CC}$ at $V_{CC} < 2.7V$
- $V_Y = V_{OH} - 0.3V$ at $V_{CC} \geq 2.7V$
- $V_Y = V_{OH} - 0.1V_{CC}$ at $V_{CC} < 2.7V$

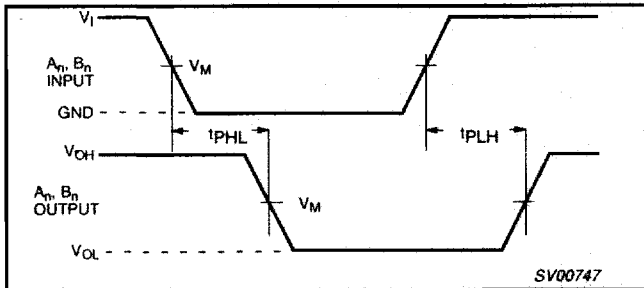

Figure 1. Input (An, Bn) to output (Bn, An) propagation delays.

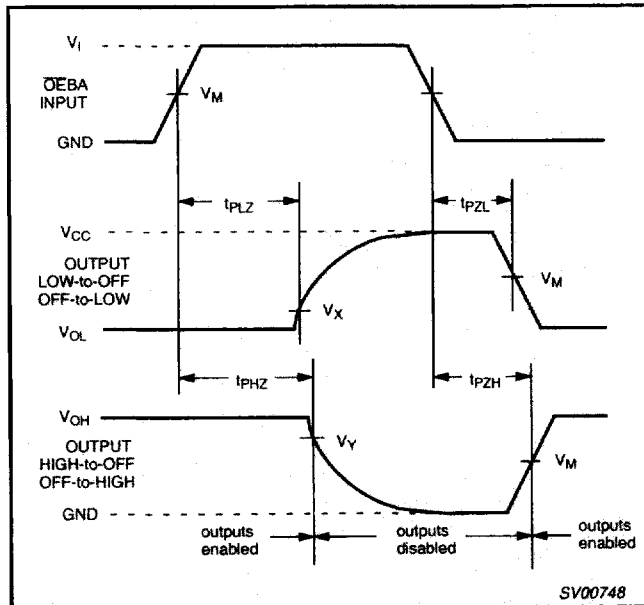

Figure 2. 3-State enable and disable times for OEBA input

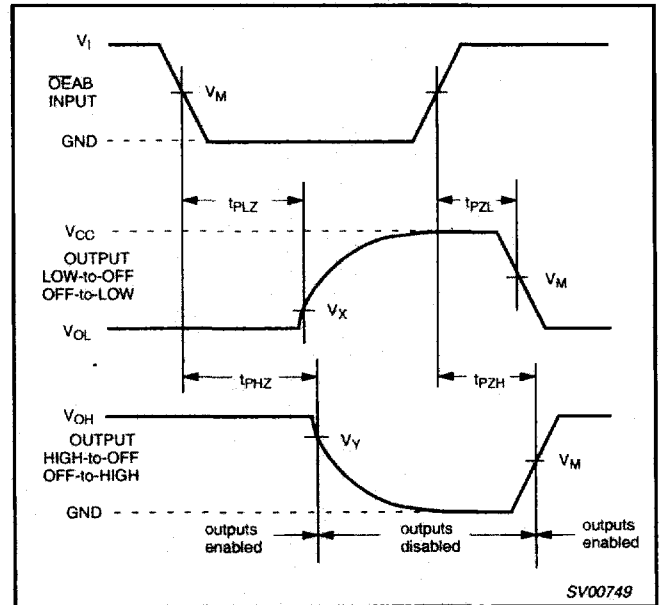

Figure 3. 3-State enable and disable times for OEAB input

TEST CIRCUIT

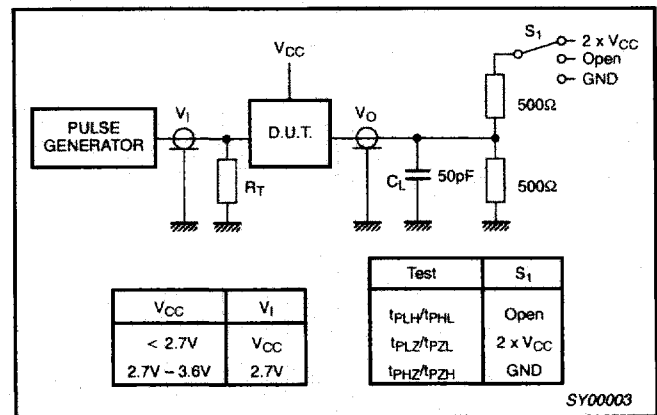

Figure 4. Load circuitry for switching times

Octal transceiver with dual enable (3-State)

74LVC623A

SO20: plastic small outline package; 20 leads; body width 7.5 mm

SOT163-1

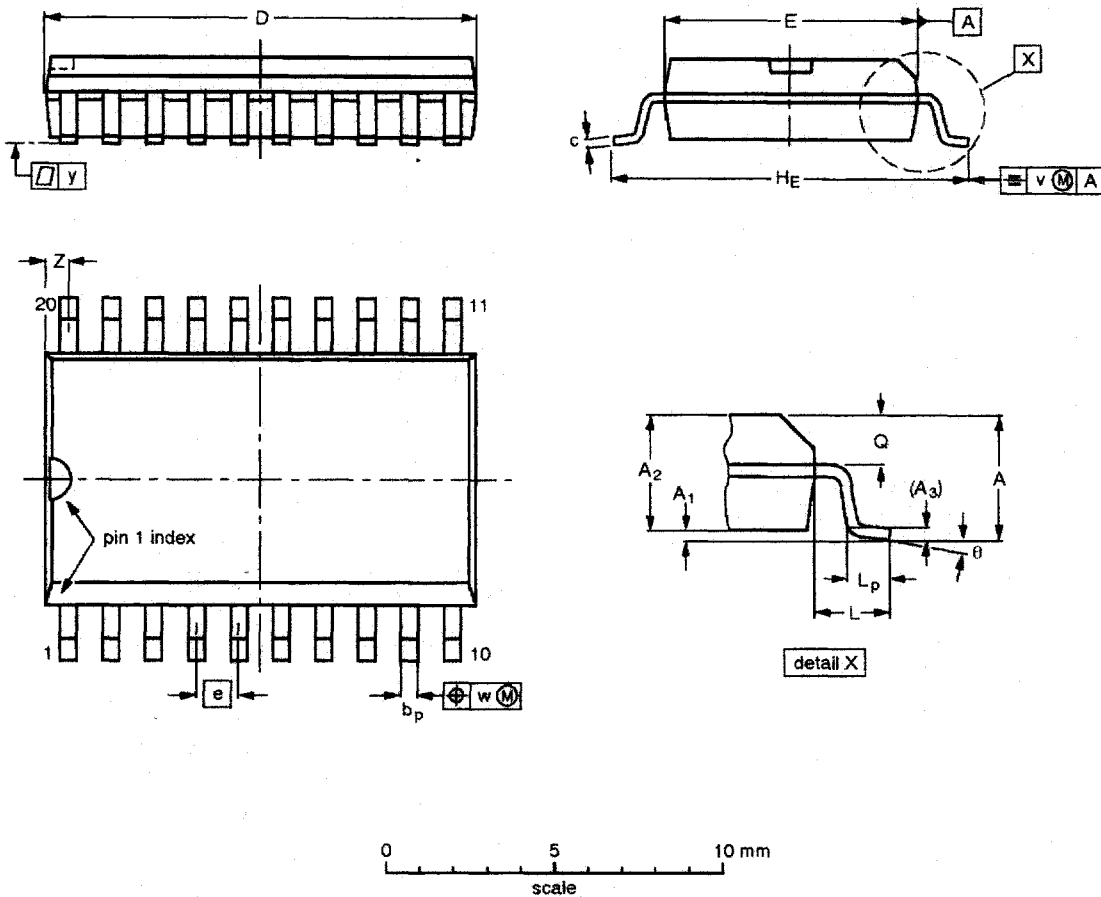

DIMENSIONS (inch dimensions are derived from the original mm dimensions)

UNIT	A max.	A ₁	A ₂	A ₃	b _p	c	D ⁽¹⁾	E ⁽¹⁾	e	H _E	L	L _p	Q	v	w	y	Z ⁽¹⁾	θ
mm	2.65	0.30 0.10	2.45 2.25	0.25	0.49 0.36	0.32 0.23	13.0 12.6	7.6 7.4	1.27	10.65 10.00	1.4	1.1 0.4	1.1 1.0	0.25	0.25	0.1	0.9 0.4	8° 0°
inches	0.10	0.012 0.004	0.096 0.089	0.01	0.019 0.014	0.013 0.009	0.51 0.49	0.30 0.29	0.050	0.42 0.39	0.055	0.043 0.016	0.043 0.039	0.01	0.01	0.004	0.035 0.016	

Note

1. Plastic or metal protrusions of 0.15 mm maximum per side are not included.

OUTLINE VERSION	REFERENCES				EUROPEAN PROJECTION	ISSUE DATE
	IEC	JEDEC	EIAJ			
SOT163-1	075E04	MS-013AC				92-11-17 95-01-24

Octal transceiver with dual enable (3-State)

74LVC623A

SSOP20: plastic shrink small outline package; 20 leads; body width 5.3 mm

SOT339-1

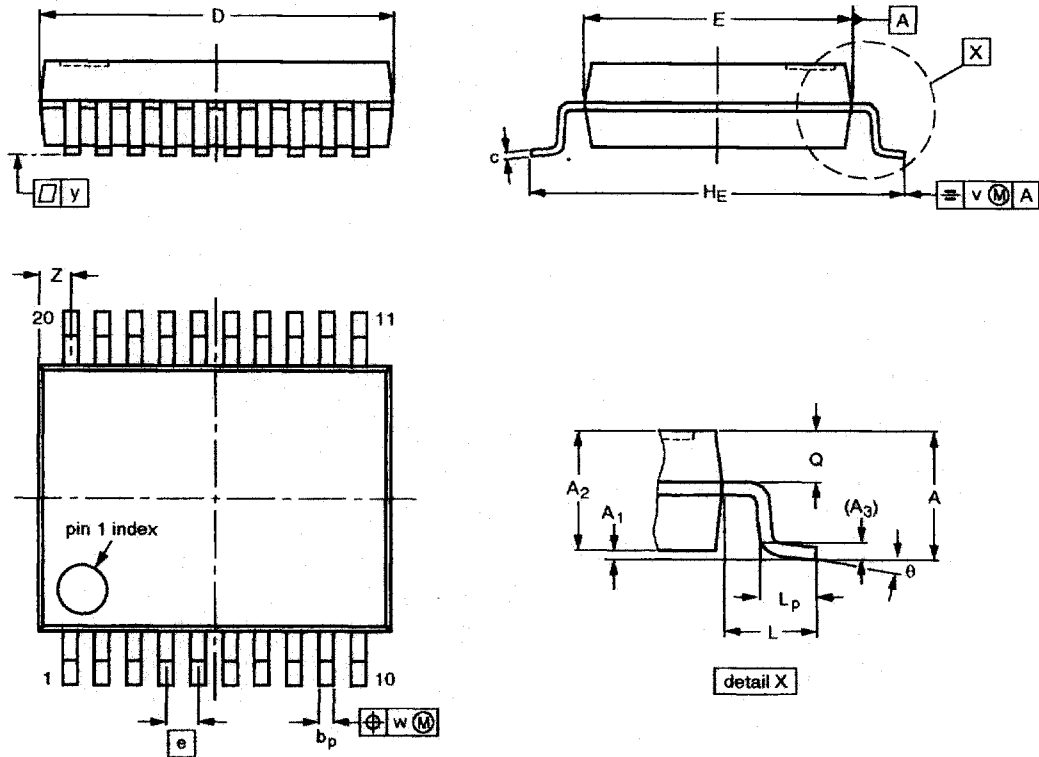

DIMENSIONS (mm are the original dimensions)

UNIT	A max.	A ₁	A ₂	A ₃	b _p	c	D ⁽¹⁾	E ⁽¹⁾	e	H _E	L	L _p	Q	v	w	y	Z ⁽¹⁾	θ
mm	2.0	0.21 0.05	1.80 1.65	0.25	0.38 0.25	0.20 0.09	7.4 7.0	5.4 5.2	0.65	7.9 7.6	1.25	1.03 0.63	0.9 0.7	0.2	0.13	0.1	0.9 0.5	8° 0°

Note

1. Plastic or metal protrusions of 0.20 mm maximum per side are not included.

OUTLINE VERSION	REFERENCES				EUROPEAN PROJECTION	ISSUE DATE
	IEC	JEDEC	EIA/J			
SOT339-1		MO-150AE				93-09-08 95-02-04

Octal transceiver with dual enable (3-State)

74LVC623A

TSSOP20: plastic thin shrink small outline package; 20 leads; body width 4.4 mm

SOT360-1

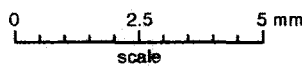
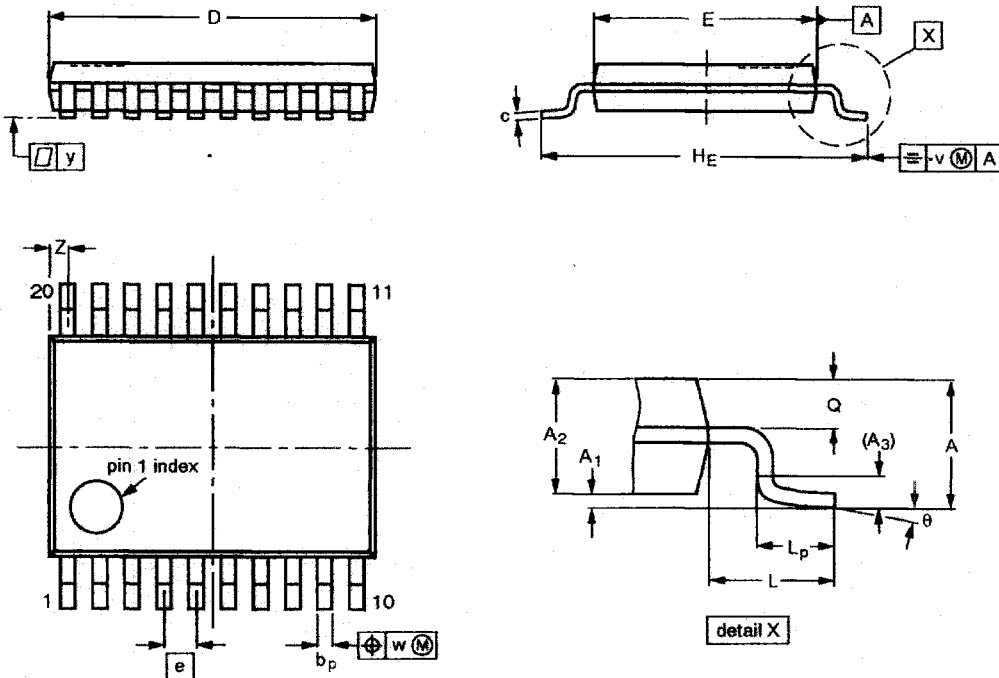

DIMENSIONS (mm are the original dimensions)

UNIT	A max.	A ₁	A ₂	A ₃	b _p	c	D ⁽¹⁾	E ⁽²⁾	e	H _E	L	L _p	Q	v	w	y	Z ⁽¹⁾	θ
mm	1.10	0.15 0.05	0.95 0.80	0.25	0.30 0.19	0.2 0.1	6.6 6.4	4.5 4.3	0.65	6.6 6.2	1.0	0.75 0.50	0.4 0.3	0.2	0.13	0.1	0.5 0.2	8° 0°

Notes

1. Plastic or metal protrusions of 0.15 mm maximum per side are not included.
2. Plastic interlead protrusions of 0.25 mm maximum per side are not included.

OUTLINE VERSION	REFERENCES				EUROPEAN PROJECTION	ISSUE DATE
	IEC	JEDEC	EIAJ			
SOT360-1		MO-153AC				93-06-16 95-02-04

Octal transceiver with dual enable (3-State)

74LVC623A

Data sheet status

Data sheet status	Product status	Definition [1]
Objective specification	Development	This data sheet contains the design target or goal specifications for product development. Specification may change in any manner without notice.
Preliminary specification	Qualification	This data sheet contains preliminary data, and supplementary data will be published at a later date. Philips Semiconductors reserves the right to make changes at any time without notice in order to improve design and supply the best possible product.
Product specification	Production	This data sheet contains final specifications. Philips Semiconductors reserves the right to make changes at any time without notice in order to improve design and supply the best possible product.

[1] Please consult the most recently issued datasheet before initiating or completing a design.

Definitions

Short-form specification — The data in a short-form specification is extracted from a full data sheet with the same type number and title. For detailed information see the relevant data sheet or data handbook.

Limiting values definition — Limiting values given are in accordance with the Absolute Maximum Rating System (IEC 134). Stress above one or more of the limiting values may cause permanent damage to the device. These are stress ratings only and operation of the device at these or at any other conditions above those given in the Characteristics sections of the specification is not implied. Exposure to limiting values for extended periods may affect device reliability.

Application information — Applications that are described herein for any of these products are for illustrative purposes only. Philips Semiconductors make no representation or warranty that such applications will be suitable for the specified use without further testing or modification.

Disclaimers

Life support — These products are not designed for use in life support appliances, devices or systems where malfunction of these products can reasonably be expected to result in personal injury. Philips Semiconductors customers using or selling these products for use in such applications do so at their own risk and agree to fully indemnify Philips Semiconductors for any damages resulting from such application.

Right to make changes — Philips Semiconductors reserves the right to make changes, without notice, in the products, including circuits, standard cells, and/or software, described or contained herein in order to improve design and/or performance. Philips Semiconductors assumes no responsibility or liability for the use of any of these products, conveys no license or title under any patent, copyright, or mask work right to these products, and makes no representations or warranties that these products are free from patent, copyright, or mask work right infringement, unless otherwise specified.

Philips Semiconductors
811 East Arques Avenue
P.O. Box 3409
Sunnyvale, California 94088-3409
Telephone 800-234-7381

© Copyright Philips Electronics North America Corporation 1998
All rights reserved. Printed in U.S.A.

print code

Date of release: 08-98

Document order number:

9397-750-04515

Let's make things better.