

SN75126 QUADRUPLE LINE DRIVER

SLLS060A – D3405, FEBRUARY 1990 – REVISED FEBRUARY 1993

- **Meets IBM 360/370 I/O Interface Specification GA22-6974-3 (Also See SN55ALS126 and SN75ALS126)**
- **Minimum Output Voltage of 3.11 V at $I_{OH} = -59.3$ mA**
- **Fault-Flag Circuit Output Signals Driver Output Fault**
- **Fault-Detection Current-Limit Circuit Minimizes Power Dissipation During a Fault Condition**
- **Dual Common Enable**
- **Individual Fault Flags**
- **Designed to Replace the MC3481**

D OR N PACKAGE
(TOP VIEW)

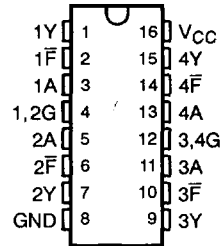

FUNCTION TABLE

INPUTS		OUTPUTS	
G	A	Y	F
L	X	L	H
H	H	H	H
H	H	S	L

H = high level,
L = low level,
X = irrelevant,
S = shorted to ground

description

The SN75126 quadruple line driver is designed to meet the IBM 360/370 I/O specification A22-6974-3. The output voltage is 3.11 V minimum (at $I_{OH} = -59.3$ mA) over the recommended ranges of supply voltage (4.5 V to 5.95 V) and temperature. Driver outputs use a fault-detection current-limit circuit to allow high drive current but still minimize power dissipation when the output is shorted to ground. The SN75126 is compatible with standard TTL logic and supply voltages.

Fault-flag circuitry is designed to sense and signal a line short on any Y line. Upon detecting an output fault condition, the fault-flag circuit forces the driver output into a low state and signals a fault condition by causing the fault-flag output to go low.

The SN75126 can drive a 50-Ω load as required in the IBM GA22-6974-3 specification or a 90-Ω load as used in many I/O systems. Optimum performance can be achieved when the device is used with either the SN75125, SN75127, SN75128, or SN75129 line receivers.

The SN75126 is characterized for operation from 0°C to 70°C.

SN75126 QUADRUPLE LINE DRIVER

SLLS060A – D3405, FEBRUARY 1990 – REVISED FEBRUARY 1993

logic symbol†

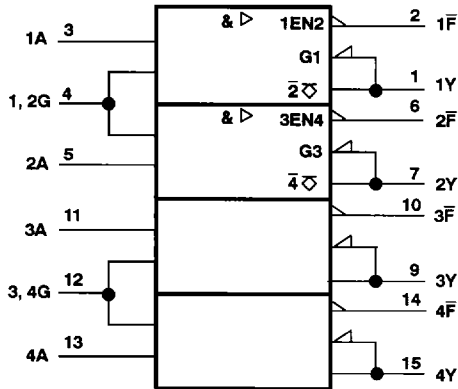

† This symbol is in accordance with ANSI/IEEE Std 91-1984 and IEC Publication 617-12.

logic diagram (positive logic)

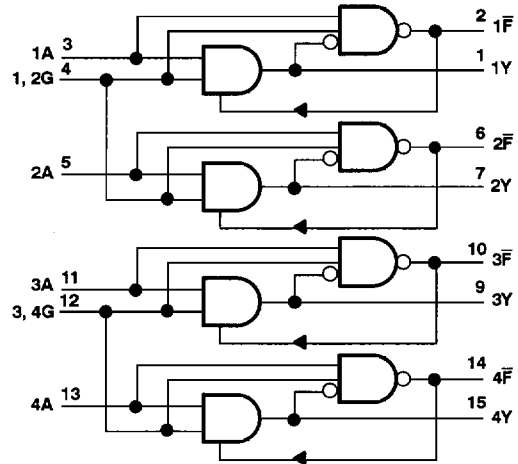

schematics of inputs and outputs

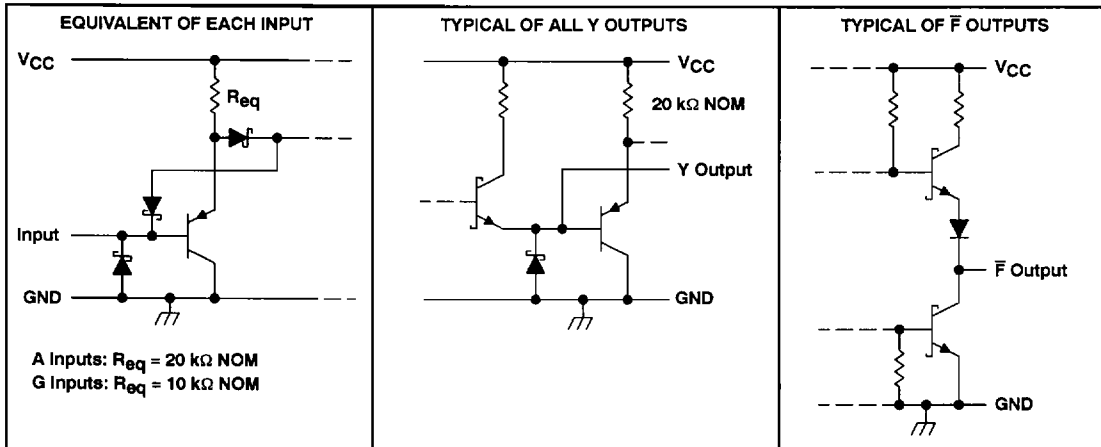

absolute maximum ratings over operating free-air temperature range (unless otherwise noted)

Supply voltage, V_{CC}	7 V
Input voltage, V_I	7 V
Continuous total power dissipation	See Dissipation Rating Table
Operating free-air temperature range, T_A	0°C to 70°C
Storage temperature range	-65°C to 150°C
Lead temperature 1,6 mm (1/16 inch) from case for 10 seconds	260°C

DISSIPATION RATING TABLE

PACKAGE	$T_A \leq 25^\circ\text{C}$ POWER RATING	DERATING FACTOR ABOVE $T_A = 25^\circ\text{C}$	$T_A = 70^\circ\text{C}$ POWER RATING
D	950 mW	7.6 mW/°C	608 mW
N	1150 mW	9.2 mW/°C	736 mW

recommended operating conditions

	MIN	NOM	MAX	UNIT
Supply voltage, V_{CC}	4.5	5	5.95	V
High-level input voltage, V_{IH}	2			V
Low-level input voltage, V_{IL}			0.8	V
High-level output current, I_{OH}			-59.3	mA
Operating free-air temperature, T_A	0		70	°C

electrical characteristics over recommended operating free-air temperature range

PARAMETER		TEST CONDITIONS		MIN	MAX	UNIT
V_{IK}	Input clamp voltage	A, G	$V_{CC} = 4.5\text{ V}$, $I_I = -18\text{ mA}$		-1.5	V
V_{OH}	High-level output voltage	Y	$V_{CC} = 4.5\text{ V}$, $I_{OH} = -59.3\text{ mA}$, $V_{IH} = 2\text{ V}$	3.11		V
		Y	$V_{CC} = 5.25\text{ V}$, $I_{OH} = -41\text{ mA}$, $V_{IH} = 2\text{ V}$	3.9		
		\bar{F}	$V_{CC} = 4.5\text{ V}$, $I_{OH} = -400\text{ }\mu\text{A}$, $V_{IH} = 2\text{ V}$	2.5		
V_{OL}	Low-level output voltage	Y	$V_{CC} = 5.5\text{ V}$, $I_{OL} = -240\text{ }\mu\text{A}$, $V_{IL} = 0.8\text{ V}$		0.15	V
		Y	$V_{CC} = 5.95\text{ V}$, $I_{OL} = -1\text{ mA}$, $V_{IL} = 0.8\text{ V}$		0.15	
		\bar{F}	$V_{CC} = 4.5\text{ V}$, $I_{OL} = 8\text{ mA}$, Y at 0 V, $V_{IH} = 2\text{ V}$		0.5	
$I_{O(off)}$	Off-state output current	Y	$V_{CC} = 4.5\text{ V}$, $V_I = 0$, $V_O = 3.11\text{ V}$		100	μA
		Y	$V_{CC} = 0$, $V_I = 0$, $V_O = 3.11\text{ V}$		200	
I_I	Input current	A	$V_{CC} = 4.5\text{ V}$, $V_I = 5.5\text{ V}$		100	μA
		G		200		
I_{IH}	High-level input current	A	$V_{CC} = 4.5\text{ V}$, $V_I = 2.7\text{ V}$		20	μA
		G		40		
I_{IL}	Low-level input current	A	$V_{CC} = 5.95\text{ V}$, $V_I = 0.4\text{ V}$		-250	μA
		G		-500		
I_{OS}	Short-circuit output current	Y	$V_{CC} = 5.5\text{ V}$, $V_O = 0$, $V_{IH} = 2.7\text{ V}$	-5		mA
		\bar{F}	$V_{CC} = 5.5\text{ V}$, $V_O = 0$	-15	-100	
		Y	$V_{CC} = 5.95\text{ V}$, $V_O = 0$, $V_{IH} = 2.7\text{ V}$	-5		
		\bar{F}	$V_{CC} = 5.95\text{ V}$, $V_O = 0$	-15	-110	
$I_{CC(H)}$	Supply current, all outputs high		$V_{CC} = 5.5\text{ V}$, No load, $V_{IH} = 2\text{ V}$		70	mA
			$V_{CC} = 5.95\text{ V}$, No load, $V_{IH} = 2\text{ V}$		80	
$I_{CC(L)}$	Supply current, Y outputs low		$V_{CC} = 5.5\text{ V}$, No load, $V_{IL} = 0.8\text{ V}$		55	mA
			$V_{CC} = 5.95\text{ V}$, No load, $V_{IL} = 0.8\text{ V}$		70	

SN75126 QUADRUPLE LINE DRIVER

SLLS060A – D3405, FEBRUARY 1990 – REVISED FEBRUARY 1993

switching characteristics at $T_A = 25^\circ\text{C}$

PARAMETER		FROM (INPUT)	TO (OUTPUT)	TEST CONDITIONS	MIN	MAX	UNIT
t_{PLH}	Propagation delay time, low-to-high-level output	A	Y	$V_{CC} = 4.5\text{ V to }5.5\text{ V}$, $R_L = 50\ \Omega$, $C_L = 50\text{ pF}$, $V_{H(\text{ref})} = 3.11\text{ V}$, See Figures 1 and 2	40	37	ns
t_{PHL}	Propagation delay time, high-to-low-level output						
$\frac{t_{PLH}}{t_{PHL}}$	Ratio of propagation delay times						
t_{PLH}	Propagation delay time, low-to-high-level output	A	Y	$V_{CC} = 5.25\text{ V to }5.95\text{ V}$, $R_L = 90\ \Omega$, $C_L = 50\text{ pF}$, $V_{H(\text{ref})} = 3.9\text{ V}$, See Figures 1 and 2	45	45	ns
t_{PHL}	Propagation delay time, high-to-low-level output						
t_{PLH}	Propagation delay time, low-to-high-level output	A	\bar{F}	$V_{CC} = 5\text{ V}$, $C_L = 15\text{ pF}$, $R_L = 2\text{ k}\Omega$, See Figures 1 and 2	60	100	ns
t_{PHL}	Propagation delay time, high-to-low-level output						

PARAMETER MEASUREMENT INFORMATION

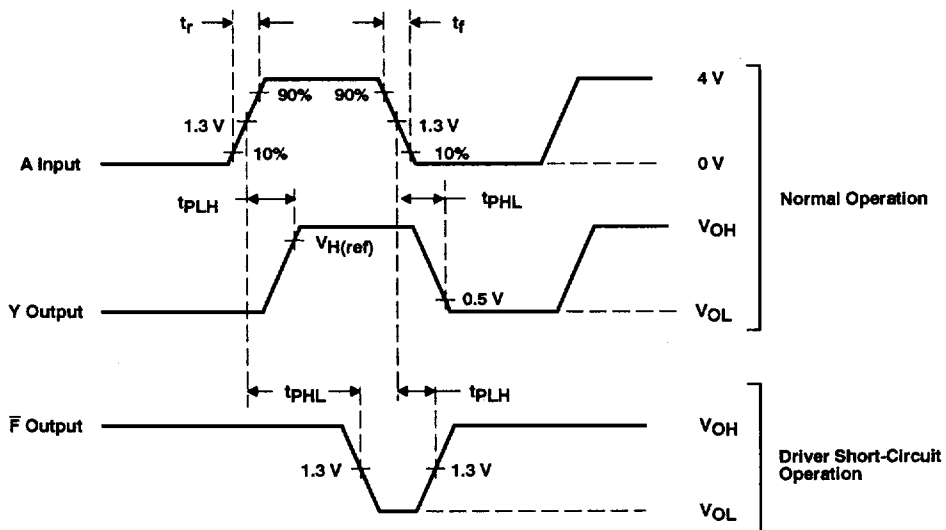

NOTE: The input pulse is supplied by a generator having the following characteristics: PRR $\leq 1\text{ MHz}$, duty cycle $\leq 50\%$, $t_r \leq 6\text{ ns}$, $t_f \leq 6\text{ ns}$, $Z_0 = 50\ \Omega$.

Figure 1. Input and Output Voltage Waveforms

PARAMETER MEASUREMENT INFORMATION

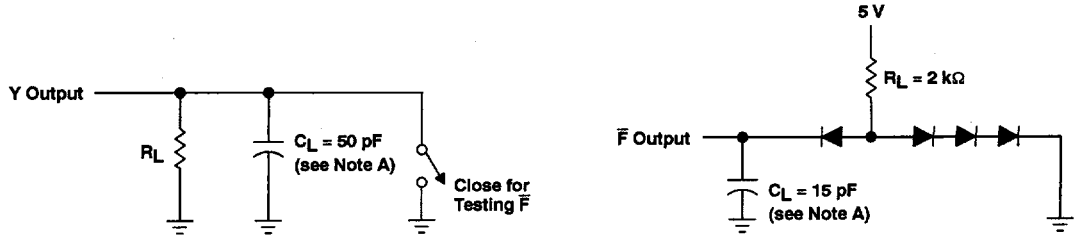

NOTE A: C_L includes probe and stray capacitance.

Figure 2. Switching Characteristics Load Circuits