



QUICKSWITCH® PRODUCTS

2.5V / 3.3V 24-BIT HIGH BANDWIDTH BUS SWITCH

IDTQS3VH16211

FEATURES:

- N channel FET switches with no parasitic diode to Vcc
 - Isolation under power-off conditions
 - No DC path to Vcc or GND
 - 5V tolerant in OFF and ON state
- 5V tolerant I/Os
- Low RON - 4Ω typical
- Flat RON characteristics over operating range
- Rail-to-rail switching 0 - 5V
- Bidirectional dataflow with near-zero delay: no added ground bounce
- Excellent RON matching between channels
- Vcc operation: 2.3V to 3.6V
- High bandwidth - up to 500 MHz
- LVTTTL-compatible control Inputs
- Undershoot Clamp Diodes on all switch and control Inputs
- Low I/O capacitance, 4pF typical
- Available in SSOP and TSSOP packages

APPLICATIONS:

- Hot-swapping
- 10/100 Base-T, Ethernet LAN switch
- Low distortion analog switch
- Replaces mechanical relay
- ATM 25/155 switching

DESCRIPTION:

The QS3VH16211 HotSwitch is a 24-bit high bandwidth bus switch. The QS3VH16211 has very low ON resistance, resulting in under 250ps propagation delay through the switch. This device operates as a 24-bit bus switch. When $\overline{1OE}$ is low, 1An is connected to 1Bn. When $\overline{2OE}$ is low, 2An is connected to 2Bn. In the OFF and ON states, the switches are 5V-tolerant. In the OFF state, the switches offer very high impedance at the terminals.

The combination of near-zero propagation delay, high OFF impedance, and over-voltage tolerance makes the QS3VH16211 ideal for high performance communications applications. It is also suitable for switching wide digital buses.

The QS3VH16211 is characterized for operation from -40°C to +85°C.

FUNCTIONAL BLOCK DIAGRAM

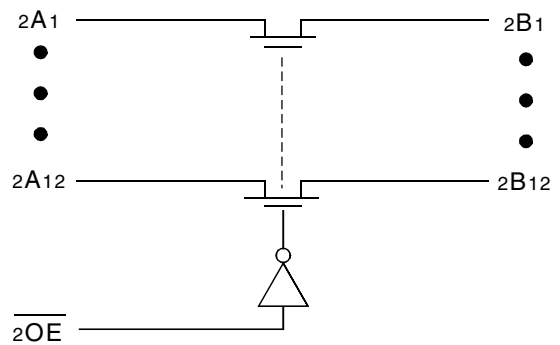
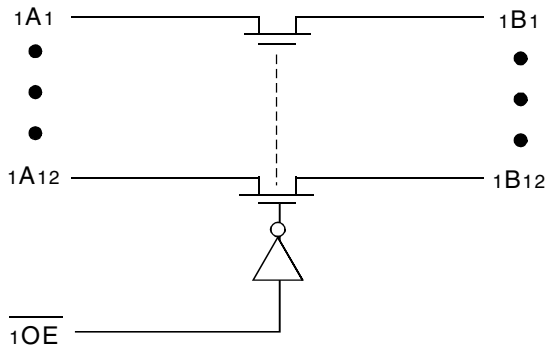

PIN CONFIGURATION

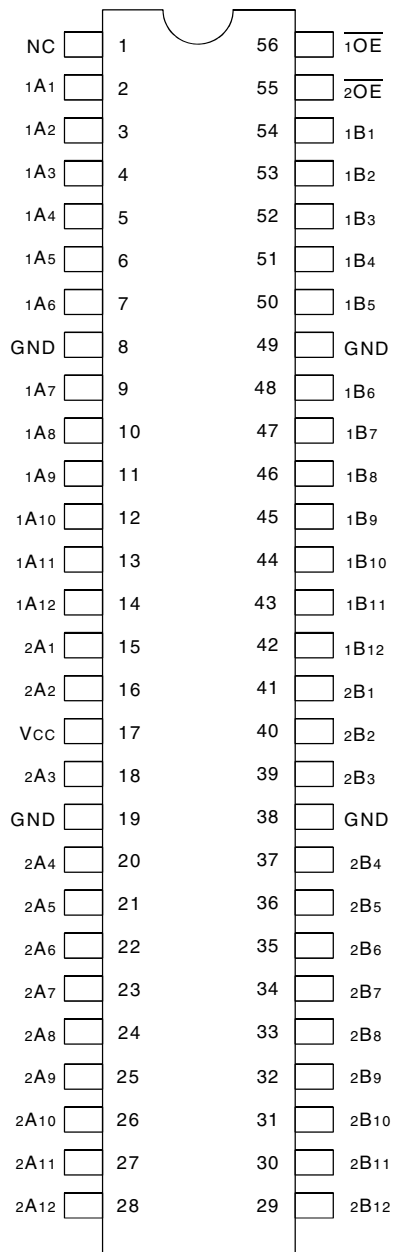

SSOP/ TSSOP
TOP VIEW

ABSOLUTE MAXIMUM RATINGS⁽¹⁾

Symbol	Description	Max.	Unit
V _{TERM} ⁽²⁾	Supply Voltage to Ground	-0.5 to 4.6	V
V _{TERM} ⁽³⁾	DC Switch Voltage V _s	-0.5 to 5.5	V
V _{TERM} ⁽³⁾	DC Input Voltage V _{IN}	-0.5 to 5.5	V
V _{AC}	AC Input Voltage (pulse width ≤20ns)	-3	V
I _{OUT}	DC Output Current (max. current/pin)	120	mA
T _{STG}	Storage Temperature	-65 to +150	°C

NOTES:

- Stresses greater than those listed under ABSOLUTE MAXIMUM RATINGS may cause permanent damage to the device. This is a stress rating only and functional operation of the device at these or any other conditions above those indicated in the operational sections of this specification is not implied. Exposure to absolute maximum rating conditions for extended periods may affect reliability.
- V_{CC} terminals.
- All terminals except V_{CC}.

CAPACITANCE (T_A = +25°C, f = 1MHz, V_{IN} = 0V, V_{OUT} = 0V)

Symbol	Parameter ⁽¹⁾	Typ.	Max.	Unit
C _{IN}	Control Inputs	3	5	pF
C _{I/O}	Quickswitch Channels (Switch OFF)	4	6	pF
C _{I/O}	Quickswitch Channels (Switch ON)	8	12	pF

NOTE:

- This parameter is guaranteed but not production tested.

PIN DESCRIPTION

Pin Names	I/O	Description
xA1 - xA12	I/O	Bus A
xB1 - xB12	I/O	Bus B
$\overline{1OE}$ - $\overline{2OE}$	I	Data Select

FUNCTION TABLE⁽¹⁾

$\overline{1OE}$	$\overline{2OE}$	1Ax	2Ax	Function
L	L	1Bx	2Bx	1Ax to 1Bx, 2Ax to 2Bx
L	H	1Bx	Z	1Ax to 1Bx
H	L	Z	2Bx	2Ax to 2Bx
H	H	Z	Z	Disconnect

NOTE:

- H = HIGH Voltage Level
L = LOW Voltage Level
Z = High-Impedence

DC ELECTRICAL CHARACTERISTICS OVER OPERATING RANGE⁽¹⁾

Following Conditions Apply Unless Otherwise Specified:

Industrial: $T_A = -40^{\circ}\text{C}$ to $+85^{\circ}\text{C}$, $V_{CC} = 3.3\text{V} \pm 0.3\text{V}$

Symbol	Parameter	Test Conditions	Min.	Typ. ⁽¹⁾	Max.	Unit		
V_{IH}	Input HIGH Voltage	Guaranteed Logic HIGH for Control Inputs	$V_{CC} = 2.3\text{V}$ to 2.7V	1.7	—	—	V	
			$V_{CC} = 2.7\text{V}$ to 3.6V	2	—	—		
V_{IL}	Input LOW Voltage	Guaranteed Logic HIGH for Control Inputs	$V_{CC} = 2.3\text{V}$ to 2.7V	—	—	0.7	V	
			$V_{CC} = 2.7\text{V}$ to 3.6V	—	—	0.8		
I_{IN}	Input Leakage Current (Control Inputs)	$0\text{V} \leq V_{IN} \leq V_{CC}$	—	—	± 1	μA		
I_{OZ}	Off-State Current (Hi-Z)	$0\text{V} \leq V_{OUT} \leq 5\text{V}$, Switches OFF	—	—	± 1	μA		
I_{OFF}	Data Input/Output Power Off Leakage	V_{IN} or V_{OUT} 0V to 5V , $V_{CC} = 0\text{V}$	—	—	± 1	μA		
R_{ON}	Switch ON Resistance	$V_{CC} = 2.3\text{V}$ (Typ. at $V_{CC} = 2.5\text{V}$)	$V_{IN} = 0\text{V}$	$I_{ON} = 30\text{mA}$	—	6	8	Ω
			$V_{IN} = 1.7\text{V}$	$I_{ON} = 15\text{mA}$	—	7	9	
		$V_{CC} = 3\text{V}$	$V_{IN} = 0\text{V}$	$I_{ON} = 30\text{mA}$	—	4	6	
			$V_{IN} = 2.4\text{V}$	$I_{ON} = 15\text{mA}$	—	5	8	

NOTE:

1. Typical values are at $V_{CC} = 3.3\text{V}$ and $T_A = 25^{\circ}\text{C}$, unless otherwise noted.

TYPICAL ON RESISTANCE vs V_{IN} AT $V_{CC} = 3.3\text{V}$

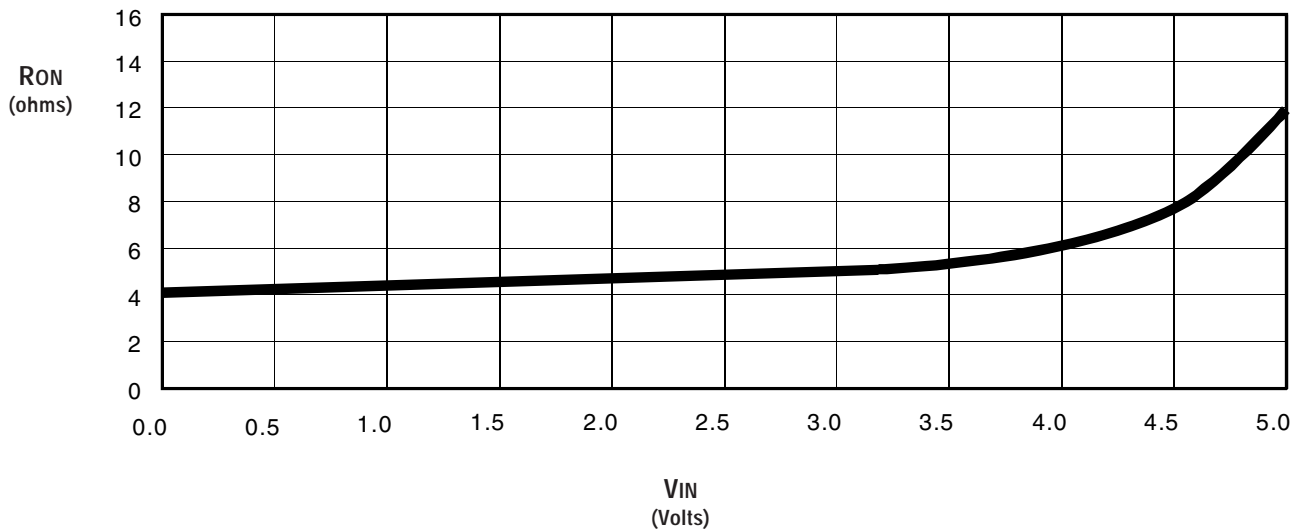

POWER SUPPLY CHARACTERISTICS

Symbol	Parameter	Test Conditions ⁽¹⁾	Min.	Typ.	Max.	Unit
I _{CC0}	Quiescent Power Supply Current	V _{CC} = Max., V _{IN} = GND or V _{CC} , f = 0	—	1.5	3	mA
ΔI _{CC}	Power Supply Current ^(2,3) per Input HIGH	V _{CC} = Max., V _{IN} = 3V, f = 0 per Control Input	—	—	30	μA
I _{CCD}	Dynamic Power Supply Current ⁽⁴⁾	V _{CC} = 3.3V, A and B Pins Open, Control Inputs Toggling @ 50% Duty Cycle	See Typical I _{CCD} vs Enable Frequency graph below			

NOTES:

1. For conditions shown as Min. or Max., use the appropriate values specified under DC Electrical Characteristics.
2. Per input driven at the specified level. A and B pins do not contribute to ΔI_{CC}.
3. This parameter is guaranteed but not tested.
4. This parameter represents the current required to switch internal capacitance at the specified frequency. The A and B inputs do not contribute to the Dynamic Power Supply Current. This parameter is guaranteed but not production tested.

TYPICAL I_{CCD} vs ENABLE FREQUENCY CURVE AT V_{CC} = 3.3V

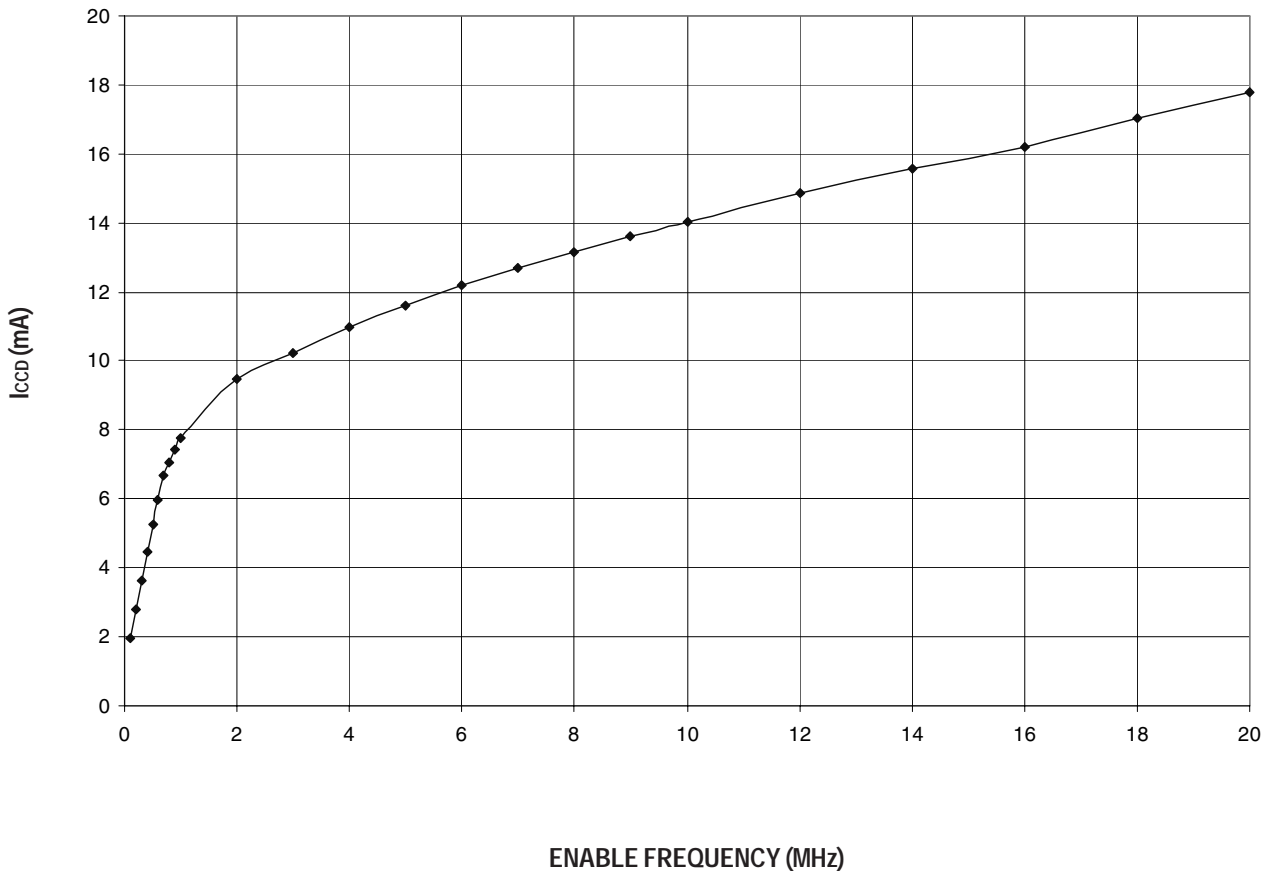

SWITCHING CHARACTERISTICS OVER OPERATING RANGE

T_A = -40°C to +85°C

Symbol	Parameter	V _{CC} = 2.5 ± 0.2V ⁽¹⁾		V _{CC} = 3.3 ± 0.3V ⁽¹⁾		Unit
		Min. ⁽⁴⁾	Max.	Min. ⁽⁴⁾	Max.	
t _{PLH} t _{PHL}	Data Propagation Delay ^(2,3) xAx to xBx or xBx to xAx	—	0.2	—	0.2	ns
t _{PZH} t _{PZL}	Switch Turn-On Delay $\overline{\text{xOE}}$ to xAx or xBx	1.5	9	1.5	9	ns
t _{PHZ} t _{PLZ}	Switch Turn-Off Delay $\overline{\text{xOE}}$ to xAx or xBx	1.5	8.5	1.5	8.5	ns
f _{xOE}	Operating Frequency - Enable ^(2,5)	—	7.5	—	20	MHz

NOTES:

1. See Test Conditions under TEST CIRCUITS AND WAVEFORMS.
2. This parameter is guaranteed but not production tested.
3. The bus switch contributes no propagation delay other than the RC delay of the ON resistance of the switch and the load capacitance. The time constant for the switch alone is of the order of 0.2ns at C_L = 50pF. Since this time constant is much smaller than the rise and fall times of typical driving signals, it adds very little propagation delay to the system. Propagation delay of the bus switch, when used in a system, is determined by the driving circuit on the driving side of the switch and its interaction with the load on the driven side.
4. Minimums are guaranteed but not production tested.
5. Maximum toggle frequency for $\overline{\text{xOE}}$ control input (pass voltage > V_{CC}, V_{IN} = 5V, R_{LOAD} ≥ 1MΩ, no C_{LOAD}).

SOME APPLICATIONS FOR HOTSWITCH PRODUCTS

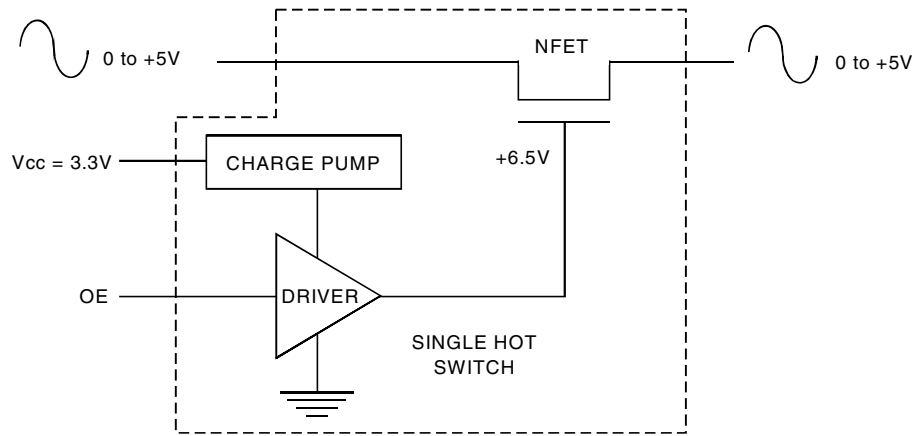

Rail-to-Rail Switching

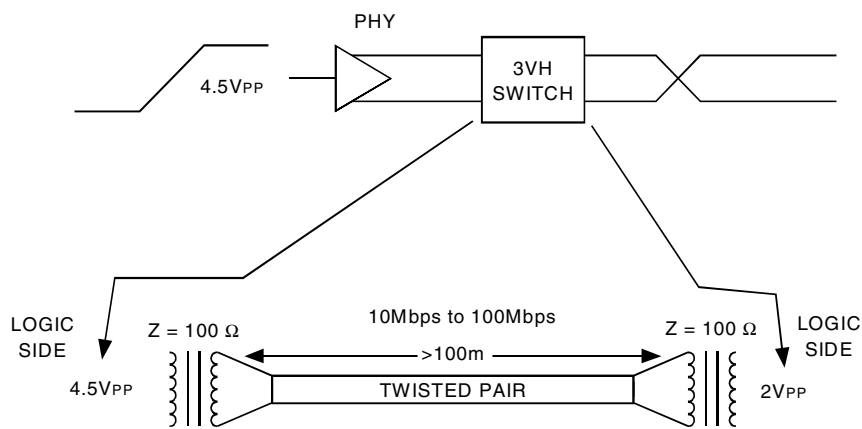

Fast Ethernet Data Switching (LAN Switch)

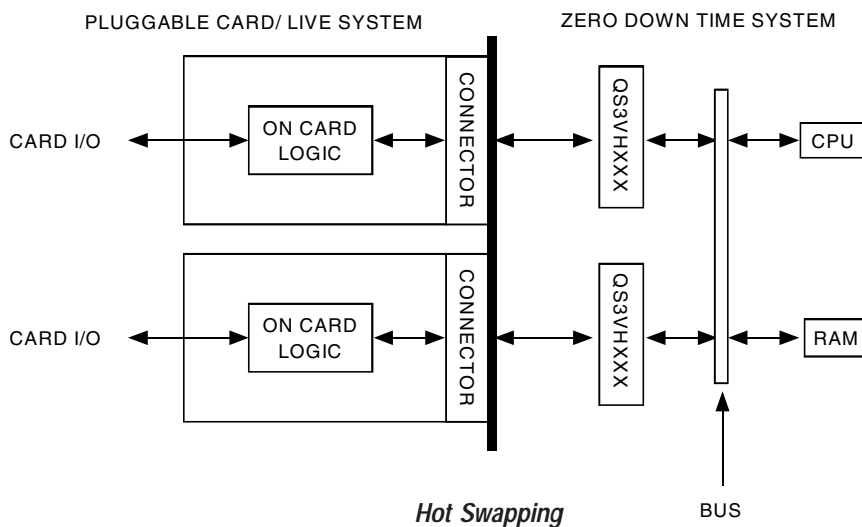

Hot Swapping

TEST CIRCUITS AND WAVEFORMS

TEST CONDITIONS

Symbol	V _{CC} ⁽¹⁾ = 3.3V ± 0.3V	V _{CC} ⁽²⁾ = 2.5V ± 0.2V	Unit
V _{LOAD}	6	2 x V _{CC}	V
V _{IH}	3	V _{CC}	V
V _T	1.5	V _{CC} /2	V
V _{LZ}	300	150	mV
V _{HZ}	300	150	mV
C _L	50	30	pF

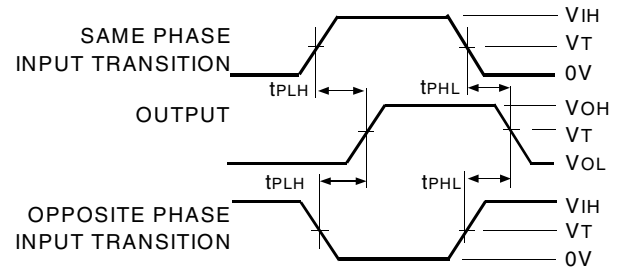

Propagation Delay

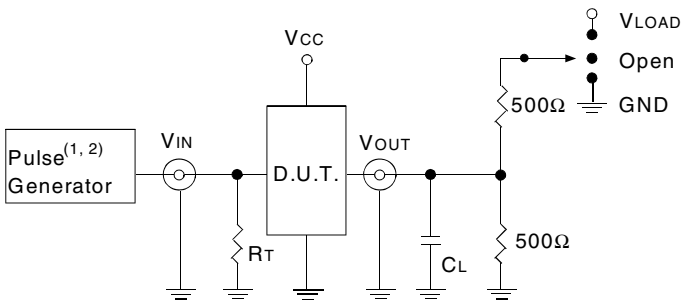

Test Circuits for All Outputs

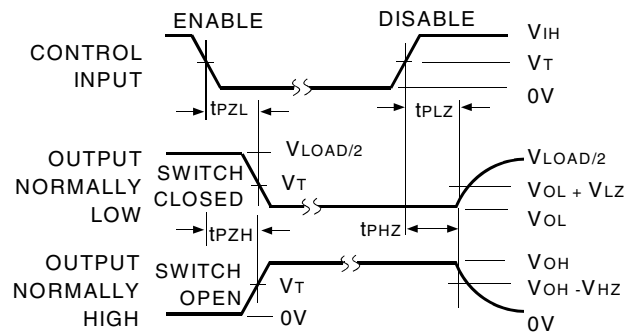

NOTE:

1. Diagram shown for input Control Enable-LOW and input Control Disable-HIGH.

Enable and Disable Times

DEFINITIONS:

C_L = Load capacitance: includes jig and probe capacitance.
R_T = Termination resistance: should be equal to Z_{OUT} of the Pulse Generator.

NOTES:

1. Pulse Generator for All Pulses: Rate ≤ 1.0MHz; t_r ≤ 2.5ns; t_r ≤ 2.5ns.
2. Pulse Generator for All Pulses: Rate ≤ 1.0MHz; t_r ≤ 2ns; t_r ≤ 2ns.

SWITCH POSITION

Test	Switch
t _{PLZ} /t _{PZL}	V _{LOAD}
t _{PHZ} /t _{PZH}	GND
t _{PD}	Open

ORDERING INFORMATION

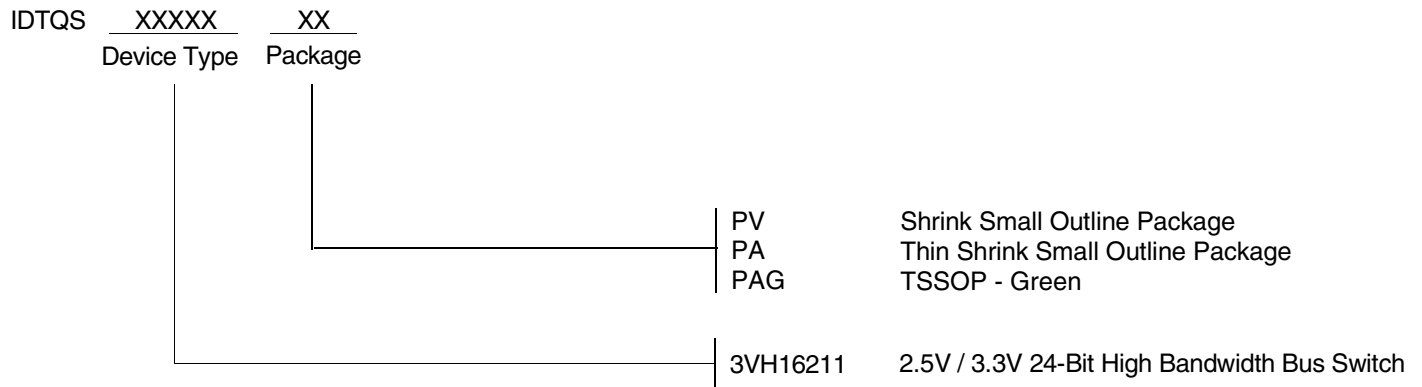

CORPORATE HEADQUARTERS
6024 Silver Creek Valley Road
San Jose, CA 95138

for SALES:
800-345-7015 or 408-284-8200
fax: 408-284-2775
www.idt.com

for Tech Support:
logichelp@idt.com