

SN54HCT373, SN74HCT373 OCTAL D-TYPE TRANSPARENT LATCHES WITH 3-STATE OUTPUTS

D2804, MARCH 1984—REVISED SEPTEMBER 1987

- Inputs are TTL-Voltage Compatible
- 8 High-Current Latches in a Single Package
- High-Current 3-State True Outputs Can Drive Up to 15 LSTTL Loads
- Full Parallel Access for Loading
- Package Options Include Plastic "Small Outline" Packages, Ceramic Chip Carriers, and Standard Plastic and Ceramic 300-mil DIPs
- Dependable Texas Instruments Quality and Reliability

SN54HCT373 . . . J PACKAGE
SN74HCT373 . . . DW OR N PACKAGE
(TOP VIEW)

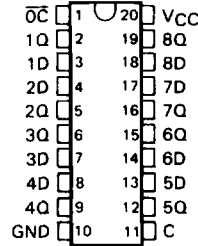

SN54HCT373 . . . FK PACKAGE
(TOP VIEW)

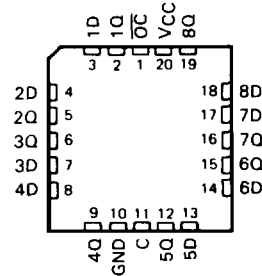

FUNCTION TABLE (EACH LATCH)

INPUTS				OUTPUT
\overline{OC}	ENABLE	C	D	Q
L	H	H	H	H
L	H	L	L	L
L	L	X	X	Q_0
H	X	X	X	Z

description

These 8-bit latches feature three-state outputs designed specifically for driving highly capacitive or relatively low-impedance loads. They are particularly suitable for implementing buffer registers, I/O ports, bidirectional bus drivers, and working registers.

The eight latches of the 'HCT373 are transparent D-type latches. While the enable (C) is high the Q outputs will follow the data (D) inputs. When the enable is taken low, the Q outputs will be latched at the levels that were set at the D inputs.

An output-control input (\overline{OC}) can be used to place the eight outputs in either a normal logic state (high or low logic levels) or a high-impedance state. In the high-impedance state the outputs neither load nor drive the bus lines significantly. The high-impedance third state and increased drive provide the capability to drive the bus lines in a bus-organized system without need for interface or pull-up components.

The output control (\overline{OC}) does not affect the internal operations of the latches. Old data can be retained or new data can be entered while the outputs are off.

The SN54HCT373 is characterized for operation over the full military temperature range of -55°C to 125°C . The SN74HCT373 is characterized for operation from -40°C to 85°C .

2

HCMOS Devices

PRODUCTION DATA documents contain information current as of publication date. Products conform to specifications per the terms of Texas Instruments standard warranty. Production processing does not necessarily include testing of all parameters.

TEXAS
INSTRUMENTS

POST OFFICE BOX 855012 • DALLAS, TEXAS 75265

Copyright © 1984, Texas Instruments Incorporated

2-413

SN54HCT373, SN74HCT373
OCTAL D-TYPE TRANSPARENT LATCHES WITH 3-STATE OUTPUTS

logic symbol†

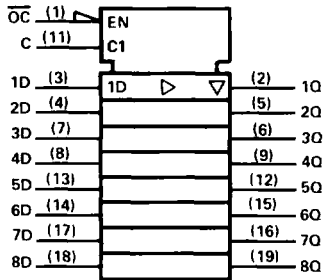

†This symbol is in accordance with ANSI/IEEE Std 91-1984 and IEC Publication 617-12.

logic diagram (positive logic)

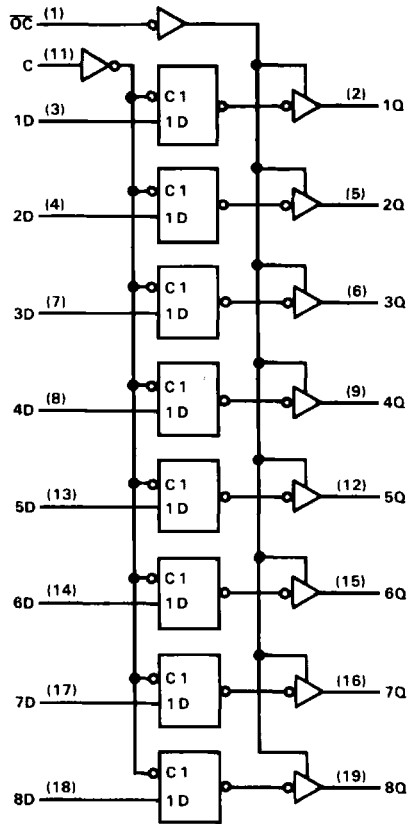

2

HC MOS Devices

SN54HCT373, SN74HCT373 OCTAL D-TYPE TRANSPARENT LATCHES WITH 3-STATE OUTPUTS

2
HCMOS Devices

absolute maximum ratings over operating free-air temperature range[†]

Supply voltage, V_{CC}	-0.5 V to 7 V
Input clamp current, I_{IK} ($V_I < 0$ or $V_I > V_{CC}$)	± 20 mA
Output clamp current, I_{OK} ($V_O < 0$ or $V_O > V_{CC}$)	± 20 mA
Continuous output current, I_O ($V_O = 0$ to V_{CC})	± 35 mA
Continuous current through V_{CC} or GND pins	± 70 mA
Lead temperature 1,6 mm (1/16 in) from case for 60 s: FK or J package	300°C
Lead temperature 1,6 mm (1/16 in) from case for 10 s: DW or N package	260°C
Storage temperature range	-65°C to 150°C

[†]Stresses beyond those listed under "absolute maximum ratings" may cause permanent damage to the device. These are stress ratings only, and functional operation of the device at these or any other conditions beyond those indicated under "recommended operating conditions" is not implied. Exposure to absolute-maximum-rated conditions for extended periods may affect device reliability.

recommended operating conditions

		SN54HCT373			SN74HCT373			UNIT
		MIN	NOM	MAX	MIN	NOM	MAX	
V_{CC}	Supply voltage	4.5	5	5.5	4.5	5	5.5	V
V_{IH}	High-level input voltage	$V_{CC} = 4.5$ V to 5.5 V			2			V
V_{IL}	Low-level input voltage	$V_{CC} = 4.5$ V to 5.5 V			0			V
V_I	Input voltage	0			V_{CC}			V
V_O	Output voltage	0			V_{CC}			V
t_t	Input transition (rise and fall) times	0			500			ns
T_A	Operating free-air temperature	-55			125			°C

electrical characteristics over recommended operating free-air temperature range (unless otherwise noted)

PARAMETER	TEST CONDITIONS	V_{CC}	$T_A = 25^\circ\text{C}$			SN54HCT373		SN74HCT373		UNIT
			MIN	TYP	MAX	MIN	MAX	MIN	MAX	
V_{OH}	$V_I = V_{IH}$ or V_{IL} , $I_{OH} = -20 \mu\text{A}$	4.5 V	4.4	4.499		4.4		4.4	V	
	$V_I = V_{IH}$ or V_{IL} , $I_{OH} = -6 \text{ mA}$	4.5 V	3.98	4.30		3.7		3.84		
V_{OL}	$V_I = V_{IH}$ or V_{IL} , $I_{OL} = 20 \mu\text{A}$	4.5 V		0.001	0.1		0.1	0.1	V	
	$V_I = V_{IH}$ or V_{IL} , $I_{OL} = 6 \text{ mA}$	4.5 V		0.17	0.26		0.4	0.33		
I_I	$V_I = V_{CC}$ or 0	5.5 V		± 0.1	± 100		± 1000	± 1000	nA	
I_{OZ}	$V_O = V_{CC}$ or 0	5.5 V		± 0.01	± 0.5		± 10	± 5	μA	
I_{CC}	$V_I = V_{CC}$ or 0, $I_O = 0$	5.5 V			8		160	80	μA	
ΔI_{CC}^\ddagger	One input at 0.5 V or 2.4 V Other inputs at 0 V or V_{CC}	5.5 V		1.4	2.4		3	2.9	mA	
C_i		4.5 V to 5.5 V		3	10		10	10	pF	

[‡]This is the increase in supply current for each input that is at one of the specified TTL voltage levels rather than 0 V or V_{CC} .



SN54HCT373, SN74HCT373
OCTAL D-TYPE TRANSPARENT LATCHES WITH 3-STATE OUTPUTS

timing requirements over recommended operating free-air temperature range (unless otherwise noted)

		V _{CC}	T _A = 25°C			SN54HCT373		SN74HCT373		UNIT
			MIN	TYP	MAX	MIN	MAX	MIN	MAX	
t _w	Pulse duration, enable C high	4.5 V 5.5 V	20			30	25	23	ns	
t _{su}	Setup time, data before enable C _I	4.5 V 5.5 V	10			15	13	12	ns	
t _h	Hold time, data after enable C _I	4.5 V 5.5 V	10			10	10	10	ns	

2

HCMOS Devices

switching characteristics over recommended operating free-air temperature range (unless otherwise noted), C_L = 50 pF (see Note 1)

PARAMETER	FROM (INPUT)	TO (OUTPUT)	V _{CC}	T _A = 25°C			SN54HCT373		SN74HCT373		UNIT
				MIN	TYP	MAX	MIN	MAX	MIN	MAX	
t _{pd}	D	Q	4.5 V 5.5 V	25	35		53	44	40	ns	
t _{pd}	C	Any Q	4.5 V 5.5 V	28	35		53	44	40	ns	
t _{en}	0̄C	Any Q	4.5 V 5.5 V	26	35		53	44	40	ns	
t _{dis}	0̄C	Any Q	4.5 V 5.5 V	23	35		53	44	40	ns	
t _t		Any Q	4.5 V 5.5 V	10	12		18	15	14	ns	

C _{pd}	Power dissipation capacitance per latch	No load, T _A = 25°C	50 pF typ
-----------------	---	--------------------------------	-----------

switching characteristics over recommended operating free-air temperature range (unless otherwise noted), C_L = 150 pF (see Note 1)

PARAMETER	FROM (INPUT)	TO (OUTPUT)	V _{CC}	T _A = 25°C			SN54HCT373		SN74HCT373		UNIT
				MIN	TYP	MAX	MIN	MAX	MIN	MAX	
t _{pd}	D	Q	4.5 V 5.5 V	32	52		79	65	59	ns	
t _{pd}	C	Any Q	4.5 V 5.5 V	38	52		79	65	59	ns	
t _{en}	0̄C	Any Q	4.5 V 5.5 V	33	52		79	65	59	ns	
t _t		Any Q	4.5 V 5.5 V	18	42		63	53	48	ns	

NOTE 1: Load circuit and voltage waveforms are shown in Section 1.