



54LS244/DM74LS244 Octal TRI-STATE® Buffers/Line Drivers/Line Receivers

General Description

These buffers/line drivers are designed to improve both the performance and PC board density of TRI-STATE buffers/drivers employed as memory-address drivers, clock drivers, and bus-oriented transmitters/receivers. Featuring 400 mV of hysteresis at each low current PNP data line input, they provide improved noise rejection and high fanout outputs and can be used to drive terminated lines down to 133Ω.

Features

- TRI-STATE outputs drive bus lines directly
- PNP inputs reduce DC loading on bus lines
- Hysteresis at data inputs improves noise margins
- Typical I_{OL} (sink current)
 - 54LS 12 mA
 - 74LS 24 mA
- Typical I_{OH} (source current)
 - 54LS -12 mA
 - 74LS -15 mA
- Typical propagation delay times
 - Inverting 10.5 ns
 - Noninverting 12 ns
- Typical enable/disable time 18 ns
- Typical power dissipation (enabled)
 - Inverting 130 mW
 - Noninverting 135 mW

Connection Diagram

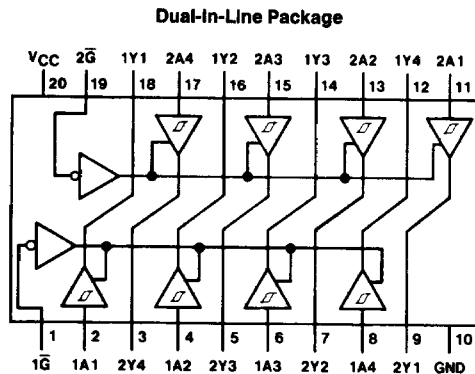

TL/F/8442-1

Order Number 54LS244DMQB, 54LS244FMQB, 54LS244LMQB,
DM74LS244WM or DM74LS244N
See NS Package Number E20A, J20A, M20B, N20A or W20A

Function Table

Inputs		Output
\bar{G}	A	Y
L	L	L
L	H	H
H	X	Z

L = Low Logic Level
H = High Logic Level
X = Either Low or High Logic Level
Z = High Impedance

Absolute Maximum Ratings (Note)

If Military/Aerospace specified devices are required, please contact the National Semiconductor Sales Office/Distributors for availability and specifications.

Supply Voltage	7V
Input Voltage	7V
Operating Free Air Temperature Range	
54LS	-55°C to +125°C
DM74LS	0°C to +70°C
Storage Temperature Range	-65°C to +150°C

Note: The "Absolute Maximum Ratings" are those values beyond which the safety of the device cannot be guaranteed. The device should not be operated at these limits. The parametric values defined in the "Electrical Characteristics" table are not guaranteed at the absolute maximum ratings. The "Recommended Operating Conditions" table will define the conditions for actual device operation.

Recommended Operating Conditions

Symbol	Parameter	54LS244			DM74LS244			Units
		Min	Nom	Max	Min	Nom	Max	
V _{CC}	Supply Voltage	4.5	5	5.5	4.75	5	5.25	V
V _{IH}	High Level Input Voltage	2			2			V
V _{IL}	Low Level Input Voltage			0.7			0.8	V
I _{OH}	High Level Output Current			-12			-15	mA
I _{OL}	Low Level Output Current			12			24	mA
T _A	Free Air Operating Temperature	-55		125	0		70	°C

Electrical Characteristics over recommended operating free air temperature range (unless otherwise noted)

Symbol	Parameter	Conditions		Min	Typ (Note 1)	Max	Units
V _I	Input Clamp Voltage	V _{CC} = Min, I _I = -18 mA				-1.5	V
HYS	Hysteresis (V _{T+} - V _{T-}) Data Inputs Only	V _{CC} = Min		0.2	0.4		V
V _{OH}	High Level Output Voltage	V _{CC} = Min, V _{IH} = Min V _{IL} = Max, I _{OH} = -1 mA	DM74	2.7			V
		V _{CC} = Min, V _{IH} = Min V _{IL} = Max, I _{OH} = -3 mA	54LS/DM74	2.4	3.4		
		V _{CC} = Min, V _{IH} = Min V _{IL} = 0.5V, I _{OH} = Max	54LS/DM74	2			
V _{OL}	Low Level Output Voltage	V _{CC} = Min V _{IL} = Max V _{IH} = Min	I _{OL} = 12 mA	54LS/DM74		0.4	V
			I _{OL} = Max	DM74		0.5	
I _{OZH}	Off-State Output Current, High Level Voltage Applied	V _{CC} = Max V _{IL} = Max V _{IH} = Min	V _O = 2.7V			20	μA
I _{OZL}	Off-State Output Current, Low Level Voltage Applied		V _O = 0.4V			-20	μA
I _I	Input Current at Maximum Input Voltage	V _{CC} = Max	V _I = 7V (DM74) V _I = 10V (54LS)			0.1	mA
I _{IH}	High Level Input Current	V _{CC} = Max	V _I = 2.7V			20	μA
I _{IL}	Low Level Input Current	V _{CC} = Max	V _I = 0.4V			-200	μA
I _{OS}	Short Circuit Output Current	V _{CC} = Max (Note 2)		54LS	-50	-225	mA
				DM74	-40		
I _{CC}	Supply Current	V _{CC} = Max, Outputs Open	Outputs High		13	23	mA
			Outputs Low		27	46	
			Outputs Disabled		32	54	

Note 1: All typicals are at V_{CC} = 5V, T_A = 25°C.

Note 2: Not more than one output should be shorted at a time, and the duration should not exceed one second.

Switching Characteristics at $V_{CC} = 5V$, $T_A = 25^\circ C$ (see Section 1 for Test Waveforms and Output Load)

Symbol	Parameter	Conditions	54LS Max	DM74LS Max	Units
t_{PLH}	Propagation Delay Time Low to High Level Output	$C_L = 45 \text{ pF}$ $R_L = 667\Omega$	18	18	ns
t_{PHL}	Propagation Delay Time High to Low Level Output	$C_L = 45 \text{ pF}$ $R_L = 667\Omega$	18	18	ns
t_{PZL}	Output Enable Time to Low Level	$C_L = 45 \text{ pF}$ $R_L = 667\Omega$	30	30	ns
t_{PZH}	Output Enable Time to High Level	$C_L = 45 \text{ pF}$ $R_L = 667\Omega$	23	23	ns
t_{PLZ}	Output Disable Time from Low Level	$C_L = 5 \text{ pF}$ $R_L = 667\Omega$	25	25	ns
t_{PHZ}	Output Disable Time from High Level	$C_L = 5 \text{ pF}$ $R_L = 667\Omega$	18	18	ns
t_{PLH}	Propagation Delay Time Low to High Level Output	$C_L = 150 \text{ pF}$ $R_L = 667\Omega$		21	ns
t_{PHL}	Propagation Delay Time High to Low Level Output	$C_L = 150 \text{ pF}$ $R_L = 667\Omega$		22	ns
t_{PZL}	Output Enable Time to Low Level	$C_L = 150 \text{ pF}$ $R_L = 667\Omega$		33	ns
t_{PZH}	Output Enable Time to High Level	$C_L = 150 \text{ pF}$ $R_L = 667\Omega$		26	ns

Note: 54LS Output Load is $C_L = 50 \text{ pF}$ for t_{PLH} , t_{PHL} , t_{PZL} and t_{PZH} .