

Fast CMOS CMOS 3.3V 6-Bit Register (Three-State)

December 1996

Features

- Advanced 0.6 micron CMOS Technology
- Advanced Low Power CMOS Operation
- Can Serve as a 5V to 3V Translator
- Excellent Output Drive Capability:
 - Balanced Drives (24mA Sink and Source)
 - Compatible with LVC™ Class of Products.
- Pin Compatible with Industry Standard Double-Density Pinouts
- Low Ground Bounce Outputs
- Hysteresis on All Inputs
- Inputs Can Be Driven by 3.3V or 5V Devices
- Multiple Center Pin and Distributed V_{CC}/GND Pins Minimizing Switching Noise

Ordering Information

PART NUMBER	TEMP. RANGE (°C)	PACKAGE	PKG. NO.
CD74FCT163374AMT	-40 to 85	48 Ld TSSOP	M48.240-P
CD74FCT163374ASM	-40 to 85	48 Ld SSOP	M48.300-P
CD74FCT163374CMT	-40 to 85	48 Ld TSSOP	M48.240-P
CD74FCT163374CSM	-40 to 85	48 Ld SSOP	M48.300-P
CD74FCT163374MT	-40 to 85	48 Ld TSSOP	M48.240-P
CD74FCT163374SM	-40 to 85	48 Ld SSOP	M48.300-P

NOTE: When ordering, use the entire part number. Add the suffix 96 to obtain the variant in the tape and reel.

Description

The CD74FCT163374 is a 16-bit octal register designed with 16 D-type flip-flops with a buffered common clock and three-state outputs. The Output Enable ($\chi\overline{OE}$) and clock (χCLK) controls are organized to operate as two 8-bit registers or one 16-bit register. When \overline{OE} is HIGH, the outputs are in the high-impedance state. Input data meeting the setup and hold time requirements of the D inputs is transferred to the O outputs on the LOW-to-HIGH transition of the clock input.

Pinout

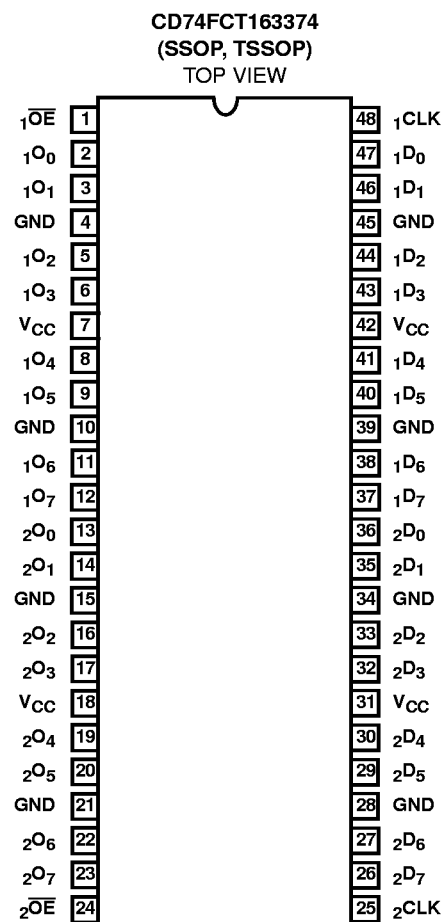

Functional Block Diagram

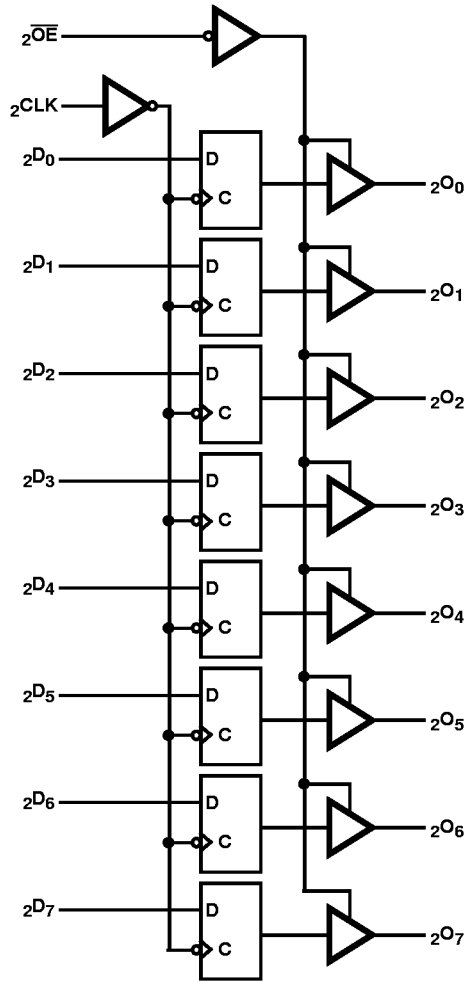
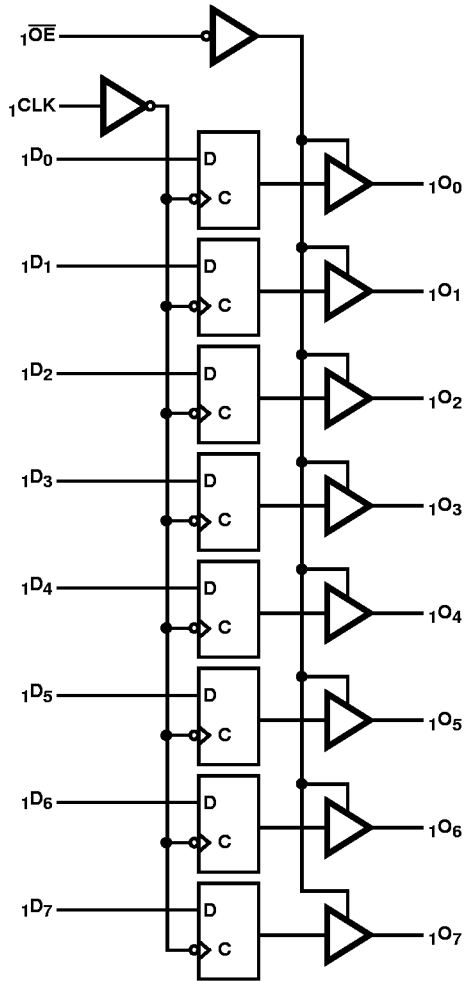

TRUTH TABLE (NOTE 1)

FUNCTION	INPUTS			OUTPUTS
	$x D_x$	$x CLK$	$x \overline{OE}$	$x O_x$
High-Z	X	L	H	Z
	X	H	H	Z
Load Register	L	↑	L	L
	H	↑	L	H
	L	↑	H	Z
	H	↑	H	Z

Pin Descriptions

PIN NAME	DESCRIPTION
$x \overline{OE}$	Three-State Output Enable Inputs (Active LOW)
$x CLK$	Clock Inputs
$x D_x$	Data Inputs
$x O_x$	Three-State Outputs
GND	Ground
V_{CC}	Power

NOTE:

- 1. H = High Voltage Level
- L = Low Voltage Level
- X = Don't Care
- Z = High Impedance
- ↑ = LOW-to-HIGH Transition

CD74FCT163374

Absolute Maximum Ratings

DC Input Voltage -0.5V to 7.0V
 DC Output Current 120mA

Operating Conditions

Operating Temperature Range -40°C to 85°C
 Supply Voltage to Ground Potential
 Inputs and V_{CC} Only -0.5V to 7.0V
 Supply Voltage to Ground Potential
 Outputs and D/O Only -0.5V to 7.0V

Thermal Information

Thermal Resistance (Typical, Note 2) θ_{JA} (°C/W)
 TSSOP Package 94
 SSOP Package 76
 Maximum Junction Temperature 150°C
 Maximum Storage Temperature Range -65°C to 150°C
 Maximum Lead Temperature (Soldering 10s) 300°C
 (Lead Tips Only)

CAUTION: Stresses above those listed in "Absolute Maximum Ratings" may cause permanent damage to the device. This is a stress only rating and operation of the device at these or any other conditions above those indicated in the operational sections of this specification is not implied.

NOTE:

- θ_{JA} is measured with the component mounted on an evaluation PC board in free air.

Electrical Specifications

PARAMETER	SYMBOL	(NOTE 3) TEST CONDITIONS		MIN	(NOTE 4) TYP	MAX	UNITS
DC ELECTRICAL SPECIFICATIONS Over the Operating Range, $T_A = -40^\circ\text{C}$ to 85°C , $V_{CC} = 2.7\text{V}$ to 3.6V							
Input HIGH Voltage (Input Pins)	V_{IH}	Guaranteed Logic HIGH Level		2.2	-	5.5	V
Input HIGH Voltage (I/O Pins)	V_{IH}	Guaranteed Logic HIGH Level		2.0	-	$V_{CC} + 0.5$	V
Input LOW Voltage (Input and I/O Pins)	V_{IL}	Guaranteed Logic LOW Level		-0.5	-	0.8	V
Input HIGH Current (Input Pins)	I_{IH}	$V_{CC} = \text{Max}$	$V_{IN} = 5.5\text{V}$	-	-	± 1	μA
Input HIGH Current (I/O Pins)	I_{IH}	$V_{CC} = \text{Max}$	$V_{IN} = V_{CC}$	-	-	± 1	μA
Input LOW Current (Input Pins)	I_{IL}	$V_{CC} = \text{Max}$	$V_{IN} = \text{GND}$	-	-	± 1	μA
Input LOW Current (I/O Pins)	I_{IL}	$V_{CC} = \text{Max}$	$V_{IN} = \text{GND}$	-	-	± 1	μA
High Impedance Output Current (Three-State)	I_{OZH}	$V_{CC} = \text{Max}$	$V_{OUT} = V_{CC}$	-	-	± 1	μA
	I_{OZL}	$V_{CC} = \text{Max}$	$V_{OUT} = \text{GND}$	-	-	± 1	μA
Clamp Diode Voltage	V_{IK}	$V_{CC} = \text{Min}$, $I_{IN} = -18\text{mA}$		-	-0.7	-1.2	V
Output HIGH Current	I_{ODH}	$V_{CC} = 3.3\text{V}$, $V_{IN} = V_{IH}$ or V_{IL} , $V_O = 1.5\text{V}$ (Note 5)		-36	-60	-110	mA
Output LOW Current	I_{ODL}	$V_{CC} = 3.3\text{V}$, $V_{IN} = V_{IH}$ or V_{IL} , $V_O = 1.5\text{V}$ (Note 5)		50	90	200	mA
Output HIGH Voltage	V_{OH}	$V_{CC} = \text{Min}$, $V_{IN} = V_{IH}$ or V_{IL}	$I_{OH} = -0.1\text{mA}$	$V_{CC} - 0.2$	-	-	V
			$I_{OH} = -3\text{mA}$	2.4	3.0	-	V
		$V_{CC} = 3.0\text{V}$, $V_{IN} = V_{IH}$ or V_{IL}	$I_{OH} = -8\text{mA}$	2.4	3.0	-	V
			$I_{OH} = -24\text{mA}$	2.0	-	-	V
Output LOW Voltage	V_{OL}	$V_{CC} = \text{Min}$, $V_{IN} = V_{IH}$ or V_{IL}	$I_{OL} = 0.1\text{mA}$	-	-	0.2	V
			$I_{OL} = 16\text{mA}$	-	0.2	0.4	V
			$I_{OL} = 24\text{mA}$	-	0.3	0.5	V

CD74FCT163374

Electrical Specifications (Continued)

PARAMETER	SYMBOL	(NOTE 3) TEST CONDITIONS	MIN	(NOTE 4) TYP	MAX	UNITS	
Short Circuit Current (Note 6)	I_{OS}	$V_{CC} = \text{Max (Note 5), } V_{OUT} = \text{GND}$	-60	-85	-240	mA	
Input Hysteresis	V_H		-	150	-	mV	
CAPACITANCE $T_A = 25^\circ\text{C, } f = 1\text{MHz}$							
Input Capacitance (Note 7)	C_{IN}	$V_{IN} = 0\text{V}$	-	4.5	6	pF	
Output Capacitance (Note 7)	C_{OUT}	$V_{OUT} = 0\text{V}$	-	5.5	8	pF	
POWER SUPPLY SPECIFICATIONS							
Quiescent Power Supply Current	I_{CC}	$V_{CC} = \text{Max}$	$V_{IN} = \text{GND}$ or V_{CC}	-	0.1	10	μA
Quiescent Power Supply Current TTL Inputs HIGH	ΔI_{CC}	$V_{CC} = \text{Max}$	$V_{IN} = V_{CC} - 0.6\text{V}$ (Note 9)	-	2.0	30	μA
Dynamic Power Supply Current (Note 10)	I_{CCD}	$V_{CC} = \text{Max, Outputs Open}$ $\overline{XOE} = \text{GND}$ One Bit Toggling 50% Duty Cycle	$V_{IN} = V_{CC}$ $V_{IN} = \text{GND}$	-	50	75	$\mu\text{A/}$ MHz
Total Power Supply Current (Note 12)	I_C	$V_{CC} = \text{Max, Outputs Open}$ $f_l = 10\text{MHz, 50\% Duty Cycle}$ $\overline{XOE} = \text{GND}$ One Bit Toggling	$V_{IN} = V_{CC} - 0.6\text{V}$ $V_{IN} = \text{GND}$	-	0.5	0.8	mA
		$V_{CC} = \text{Max, Outputs Open}$ $f_l = 2.5\text{MHz, 50\% Duty Cycle}$ $\overline{XOE} = \text{GND}$ 16 Bits Toggling	$V_{IN} = V_{CC} - 0.6\text{V}$ $V_{IN} = \text{GND}$	-	2.5	4.0 (Note 11)	mA

CD74FCT163374

Switching Specifications Over Operating Range (Note 13)

PARAMETER	SYMBOL	(NOTE 14) TEST CONDITIONS	CD74FCT163374		CD74FCT163374A		CD74FCT163374C		UNITS
			(NOTE 15) MIN	MAX	(NOTE 15) MIN	MAX	(NOTE 15) MIN	MAX	
Propagation Delay χ_{CLK} to χ_{OX}	t_{PLH} , t_{PHL}	$C_L = 50\text{pF}$ $R_L = 500\Omega$	2.0	10.0	2.0	6.5	2.0	5.2	ns
Output Enable Time χ_{OE} to χ_{OX}	t_{PZH} , t_{PZL}		1.5	12.5	1.5	6.5	1.5	5.5	ns
Output Disable Time (Note 16) χ_{OE} to χ_{OX}	t_{PHZ} , t_{PLZ}		1.5	8.0	1.5	5.5	1.5	5.0	ns
Setup Time HIGH or LOW, χ_{DX} to χ_{CLK}	t_{SU}		2.0	-	2.0	-	2.0	-	ns
Hold Time HIGH or LOW, χ_{DX} to χ_{CLK}	t_H		1.5	-	1.5	-	1.5	-	ns
χ_{CLK} Pulse Width HIGH (Note 16)	t_W		7.0	-	5.0	-	5.0	-	ns
Output Skew (Note 17)	$t_{SK(O)}$		-	0.5	-	0.5	-	0.5	ns

NOTES:

3. For conditions shown as Max or Min, use appropriate value specified under Electrical Specifications for the applicable device type.
4. Typical values are at $V_{CC} = 3.3\text{V}$, 25°C ambient and maximum loading.
5. Not more than one output should be shorted at one time. Duration of the test should not exceed one second.
6. This parameter is guaranteed but not tested.
7. This parameter is determined by device characterization but is not production tested.
8. $V_{OH} = V_{CC} - 0.6\text{V}$ at rated current.
9. Per TTL driven input; all other inputs at V_{CC} or GND.
10. This parameter is not directly testable, but is derived for use in Total Power Supply Calculations.
11. Values for these conditions are examples of the I_{CC} formula. These limits are guaranteed but not tested.
12. $I_C = I_{QUIESCENT} + I_{INPUTS} + I_{DYNAMIC}$
 $I_C = I_{CC} + \Delta I_{CC} D_H N_T + I_{CCD} (f_{CP}/2 + f_i N_i)$
 I_{CC} = Quiescent Current
 ΔI_{CC} = Power Supply Current for a TTL High Input
 D_H = Duty Cycle for TTL Inputs High
 N_T = Number of TTL Inputs at D_H
 I_{CCD} = Dynamic Current Caused by an Input Transition Pair (HLH or LHL)
 f_{CP} = Clock Frequency for Register Devices (Zero for Non-Register Devices)
 N_{CP} = Number of Clock Inputs at f_{CP}
 f_i = Input Frequency
 N_i = Number of Inputs at f_i
 All currents are in milliamps and all frequencies are in megahertz.
13. Propagation Delays and Enable/Disable times are with $V_{CC} = 3.3\text{V} \pm 0.3\text{V}$, normal range. For $V_{CC} = 2.7\text{V}$, extended range, all Propagation Delays and Enable/Disable times should be degraded by 20%.
14. See test circuits and waveforms.
15. Minimum limits are guaranteed but not tested on Propagation Delays.
16. This parameter is guaranteed but not production tested.
17. Skew between any two outputs, of the same package, switching in the same direction. This parameter is guaranteed by design.

Test Circuits and Waveforms

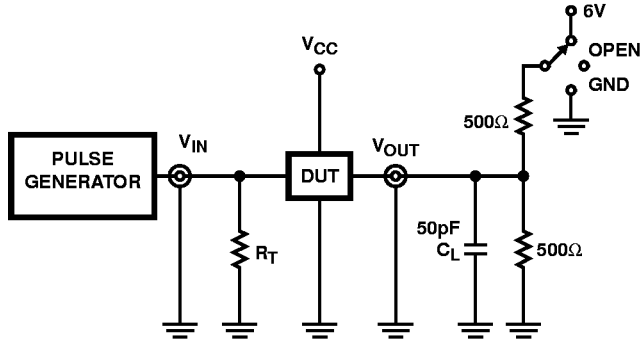

SWITCH POSITION	
TEST	SWITCH
t_{PLZ} , t_{PZL} , Open Drain	6V
t_{PHZ} , t_{PZH}	GND
t_{PLH} , t_{PHL}	Open

DEFINITIONS:

C_L = Load capacitance, includes jig and probe capacitance.
 R_T = Termination resistance, should be equal to Z_{OUT} of the Pulse Generator.

NOTE:

18. Pulse Generator for All Pulses: Rate $\leq 1.0\text{MHz}$; $Z_{OUT} \leq 50\Omega$;
 t_f , $t_r \leq 2.5\text{ns}$.

FIGURE 1. TEST CIRCUIT

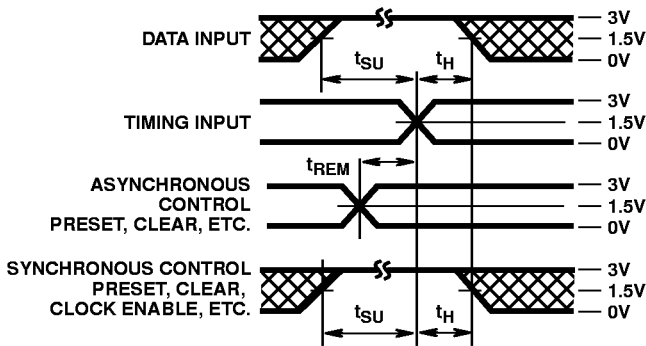

FIGURE 2. SETUP, HOLD, AND RELEASE TIMING

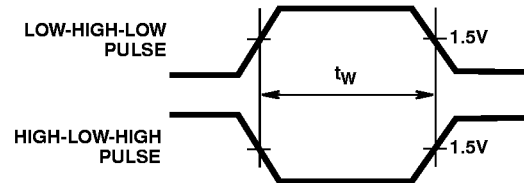

FIGURE 3. PULSE WIDTH

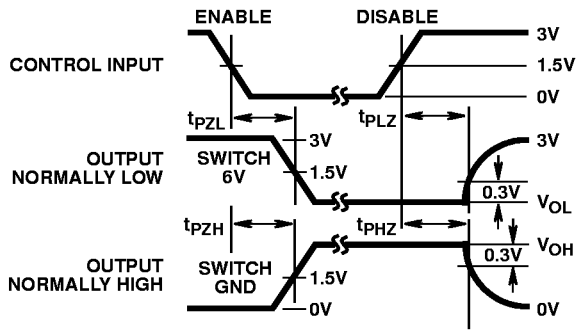

FIGURE 4. ENABLE AND DISABLE TIMING

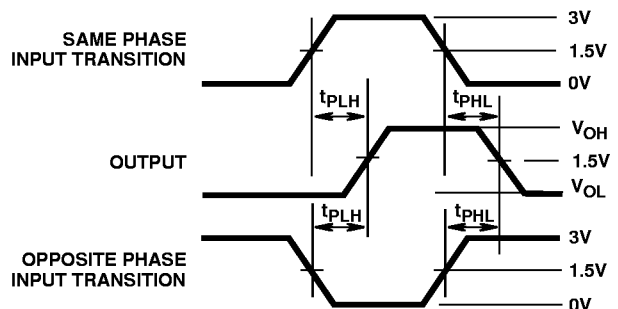

FIGURE 5. PROPAGATION DELAY