

LM3492HC/LM3492HCQ

Two-Channel Individual Dimmable LED Driver with Boost Converter and Fast Current Regulator

General Description

The LM3492HC integrates a boost converter and a two-channel current regulator to implement a high efficient and cost effective LED driver for driving two individually dimmable LED strings with a maximum power of 15W and an output voltage of up to 65V. The boost converter employs a proprietary Projected-On-Time control method to give a fast transient response with no compensation required, and a nearly constant switching frequency programmable from 200 kHz to 1 MHz. The application circuit is stable with ceramic capacitors and produces no audible noise on dimming. The programmable peak current limit and soft-start features reduce current surges at startup, and an integrated 190 m Ω , 3.9A N-Channel MOSFET switch minimizes the solution size. The fast slew rate current regulator allows high frequency and narrow pulse width dimming signals to achieve a very high contrast ratio of 10000:1. The LED current is programmable from 50 mA to 250 mA by a single resistor.

To maximize the efficiency, Dynamic Headroom Control (DHC) automatically adjusts the output voltage to a minimum. DHC also facilitates a single BOM for different number of LED in a string, which is required for backlight panels of different size, thereby reducing overall development time and cost. The LM3492HC comes with a versatile COMM pin which serves as a bi-directional I/O pin interfacing with an external MCU for the following functions: power-good, over-temperature, IOUT over- and under-voltage indications, switching frequency tuning, and channel 1 disabling. Other supervisory functions of the LM3492HC include precise enable, VCC under-voltage lock-out, current regulator over-power protection, and thermal shutdown protection. The LM3492HC is available in the thermally enhanced eTSSOP-20 package.

Features

Boost Converter:

- LM3492HCQ is an Automotive Grade Product that is AEC Q100 grade 1 qualified
- Very wide input voltage ranged from 4.5V-65V
- Programmable soft-start
- No loop compensation required
- Stable with ceramic and other low ESR capacitors with no audible noise
- Nearly constant switching frequency programmable from 200 kHz to 1 MHz

Current Regulators:

- Programmable LED current from 50 mA to 250 mA
- 10000:1 contrast ratio, 300 ns minimum pulse width
- Two individual dimmable LED strings up to 65V, total 15W (typically 28 LEDs @ 150 mA)
- Dynamic Headroom Control maximizes efficiency
- Over-Power protection
- $\pm 3\%$ current accuracy

Supervisory Functions:

- Precision enable
- COMM I/O pin for diagnostic and commands
- Thermal shutdown protection
- Thermally enhanced eTSSOP-20 package

Applications

- Ultra-high contrast ratio 6.5"-10" LCD display backlight up to 28 LEDs
- Automotive or marine GPS display

Typical Application

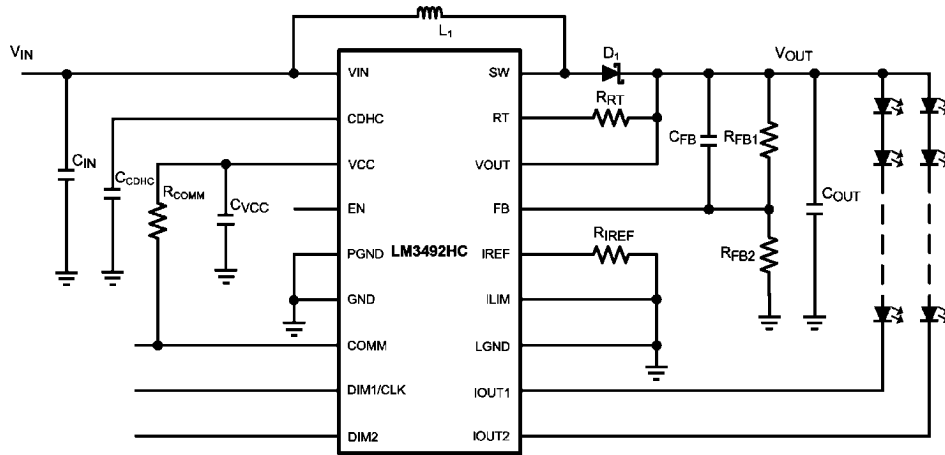

30170528

Connection Diagram

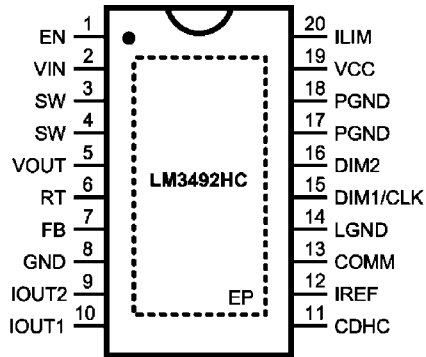

30170502

Top View
20-Lead Plastic eTSSOP (MXA20A)

Ordering Information

Order Number	Package Type	NSC Package Drawing	Supplied As	Feature
LM3492HCMH	Exposed Pad TSSOP-20	MXA20A	73 Units per Anti-Static Tube	
LM3492HCMHX			2500 Units on Tape and Reel	
LM3492HCQMH			73 Units per Anti-Static Tube	AEC-Q100 Grade 1 qualified. Automotive Grade Production Flow*
LM3492HCQMHX			2500 Units on Tape and Reel	

*Automotive Grade (Q) product incorporates enhanced manufacturing and support processes for the automotive market, including defect detection methodologies. Reliability qualification is compliant with the requirements and temperature grades defined in the AEC-Q100 standard. Automotive grade products are identified with the letter Q. For more information go to <http://www.national.com/automotive>.

Pin Descriptions

Pin	Name	Description	Application Information
1	EN	Enable	Internally pull-up. Connect to a voltage higher than 1.63V to provide precision enable for the device.
2	VIN	Input Supply Voltage	Supply pin to the device. Input range is 4.5V to 65V.
3, 4	SW	Switch Node	Internally connected to the drain of the integrated MOSFET.
5	VOUT	Output Voltage Sense	Sense the output voltage for nearly constant switching frequency control.
6	RT	Frequency Control	An external resistor from the VOUT pin to this pin sets the switching frequency.
7	FB	Output Voltage Feedback	The output voltage is connected to this pin through a feedback resistor divider for output voltage regulation. The dynamic range of this pin is from 1.05V to 2.0V.
8	GND	Analog Ground	Signal Ground
9	IOUT2	Current Regulator Input of Channel 2	Input of the current regulator of channel 2. The regulated current is programmable (refer to the IREF pin).
10	IOUT1	Current Regulator Input of Channel 1	Input of the current regulator of channel 1. The regulated current is programmable (refer to the IREF pin).
11	CDHC	Dynamic Headroom Control	An external capacitor connected to this pin sets the DHC sensitivity. At startup, a 120 μ A internal current source charges an external capacitor to provide a soft-start function.
12	IREF	Current Setting of the Current Regulator	An external resistor connected from this pin to ground programs the regulated current of the current regulator of channels 1 and 2.
13	COMM	Bi-directional Logic Communication	This pin is open drain for various indications (power-good, over-temperature, IOUT over- and under-voltage) and command sending (switching frequency tuning and channel 1 disabling).
14	LGND	Ground of the Current Regulator	Current regulator ground. Must be connected to the GND pin for normal operation. The LGND and GND pins are not internally connected.
15	DIM1/CLK	Dimming Control of Channel 1	Control the on/off of the current regulator of channel 1. This pin is internally pulled low by a 5 μ A current. This pin also serves as a clock signal for latching input/output data of the COMM pin.
16	DIM2	Dimming Control of Channel 2	Control the on/off of the current regulator of channel 2. This pin is internally pulled low by a 5 μ A current.
17, 18	PGND	Power Ground	Integrated MOSFET ground. Must be connected to the GND pin for normal operation. The PGND and GND pins are not internally connected.
19	VCC	LDO Regulator Output	Nominally regulated to 5.5V. Connect a capacitor of larger than 0.47 μ F between the VCC and GND pins.
20	ILIM	Peak Current Limit Adjust	Connect an external resistor from the ILIM pin to the VCC pin reduces peak current limit. Connect the ILIM pin to the ground to obtain the maximum current limit.
DAP	DAP	Exposed Pad	Thermal connection pad. Connect to a ground plane.

Absolute Maximum Ratings (Note 1)

If Military/Aerospace specified devices are required, please contact the Texas Instruments Sales Office/ Distributors for availability and specifications.

VIN, RT, VOUT to GND	-0.3V to 67V
SW to GND	-0.3V to 67V
SW to GND (Transient)	-2V (<100 ns)
ILIM to GND	-0.3V to 1V
FB to GND	-0.3V to 5V
COMM, DIM1, DIM2, to GND	-0.3V to 6V

ESD Rating (Note 2)

Human Body Model	±2kV
Storage Temperature Range	-65°C to +150°C
Junction Temperature (T _J)	150°C

Operating Ratings (Note 1)

Supply Voltage (VIN)	4.5V to 65V
Operation Temperature Range (T _A)	-40°C to +125°C
Thermal Resistance (θ _{JA}) (Note 3)	32.7°C/W

Electrical Characteristics Specification with standard type are for T_A = T_J = +25°C only; limits in boldface type apply over the full Operating Junction Temperature (T_J) range. Minimum and Maximum are guaranteed through test, design or statistical correlation. Typical values represent the most likely parametric norm at T_J = +25°C, and are provided for reference purposes only. Unless otherwise stated the following conditions apply: V_{IN} = 12V.

Symbol	Parameter	Conditions	Min	Typ	Max	Units
Start-Up Regulator, VCC						
V _{CC}	VCC pin output voltage	C _{VCC} = 0.47 μF, no load	4.7	5.5	6.3	V
		I _{CC} = 2 mA	4.7	5.5	6.3	V
V _{CC-UVLO}	VCC pin under-voltage lockout threshold (UVLO)	V _{CC} increasing	3.56	3.78	4.00	V
V _{CC-UVLO-HYS}	VCC pin UVLO hysteresis	V _{CC} decreasing		310		mV
I _{IN}	I _{IN} operating current	No switching, V _{FB} = 0V		3.6	5.2	mA
I _{IN-SD}	I _{IN} operating current, Device shutdown	V _{EN} = 0V		30	95	μA
I _{VCC}	VCC pin current limit (Note 4)	V _{CC} = 0V	18	30		mA
V _{CC-VOUT}	VCC pin output voltage when supplied by VOUT	V _{IN} = Open, I _{CC} = 1 mA, V _{OUT} = 18V	3.5	4.1	4.7	V
Enable Input						
V _{EN}	EN pin input threshold	V _{EN} rising	1.55	1.63	1.71	V
V _{EN-HYS}	EN pin threshold hysteresis	V _{EN} falling		194		mV
I _{EN-SHUT}	Enable Pull-up Current at shutdown	V _{EN} = 0V		2		μA
I _{EN-OPER}	Enable Pull-up Current during operation	V _{EN} = 2V		40		μA
Current Regulator						
V _{IREF}	IREF pin voltage	V _{IN} = 4.5V to 65V	1.231	1.256	1.281	V
V _{DHC50}	V _{IOUT} under DHC at I _{OUT} = 50 mA	R _{IREF} = 25 kΩ	0.160	0.225	0.290	V
V _{DHC100}	V _{IOUT} under DHC at I _{OUT} = 100 mA	R _{IREF} = 12.5 kΩ	0.38	0.48	0.58	V
V _{DHC200}	V _{IOUT} under DHC at I _{OUT} = 200 mA	R _{IREF} = 6.25 kΩ	0.81	0.99	1.17	V
V _{DHC250}	V _{IOUT} under DHC at I _{OUT} = 250 mA	R _{IREF} = 5 kΩ	0.81	1.21	1.44	V
I _{OUT50}	Current Output under DHC at V _{IOUT} = V _{DHC50}	R _{IREF} = 25 kΩ, V _{IOUT} = V _{DHC50}	47.5	50	52.5	mA
		R _{IREF} = 25 kΩ, V _{IOUT} = V _{DHC50}	46.5	50	53.5	mA
I _{OUT100}	Current Output under DHC at V _{IOUT} = V _{DHC100}	R _{IREF} = 12.5 kΩ, V _{IOUT} = V _{DHC100}	97	100	103	mA
		R _{IREF} = 12.5 kΩ, V _{IOUT} = V _{DHC100}	96	100	104	mA
I _{OUT200}	Current Output under DHC at V _{IOUT} = V _{DHC200}	R _{IREF} = 6.25 kΩ, V _{IOUT} = V _{DHC200}	194	200	206	mA
		R _{IREF} = 6.25 kΩ, V _{IOUT} = V _{DHC200}	192	200	208	mA
I _{OUT250}	Current Output under DHC at V _{IOUT} = V _{DHC250}	R _{IREF} = 5 kΩ, V _{IOUT} = V _{DHC250}	241.3	250	258.8	mA
		R _{IREF} = 5 kΩ, V _{IOUT} = V _{DHC250}	238	250	262	mA
I _{OUTOFF}	Leakage at Maximum Work Voltage	V _{DIM} = 0, V _{IOUT} = 65V			5	μA
V _{IOUT50-MIN}	Minimum Work Voltage, 50 mA	R _{IREF} = 25 kΩ, I _{OUT} = 0.98 x I _{OUT50}		0.1	0.15	V
V _{IOUT100-MIN}	Minimum Work Voltage, 100 mA	R _{IREF} = 12.5 kΩ, I _{OUT} = 0.98 x I _{OUT100}		0.2	0.35	V
V _{IOUT200-MIN}	Minimum Work Voltage, 200 mA	R _{IREF} = 6.25 kΩ, I _{OUT} = 0.98 x I _{OUT200}		0.4	0.65	V

Symbol	Parameter	Conditions	Min	Typ	Max	Units
$V_{IOUT250-MIN}$	Minimum Work Voltage, 250 mA	$R_{IREF} = 5\text{ k}\Omega$, $I_{OUT} = 0.98 \times I_{OUT250}$		0.5	0.82	V
$V_{DIM-HIGH}$	DIM Voltage HIGH		1.17			V
$V_{DIM-LOW}$	DIM Voltage LOW				0.7	V
Boost Converter						
$I_{CDHC-SRC}$	CDHC pin source current	$V_{CDHC} = 1.6\text{V}$, $V_{FB} = 3\text{V}$, $V_{IOUT} = 0\text{V}$, DIM = High		60		μA
$I_{CDHC-SINK}$	CDHC pin sink current	$V_{CDHC} = 1.6\text{V}$, $V_{FB} = 3\text{V}$, $V_{IOUT} = 3\text{V}$, DIM = High		56		μA
$I_{CDHC-PULLUP}$	CDHC pin pull-up current	DIM = Low, $V_{CDHC} = 2.3\text{V}$, $V_{FB} = 3\text{V}$	10	200	500	nA
I_{CL-MAX}	Integrated MOSFET peak current limit threshold		3.3	3.9	4.5	A
$I_{CL-HALF}$	Half integrated MOSFET peak current limit threshold	$R_{ILIM} = 11\text{ k}\Omega$		2.0		A
$R_{DS(on)}$	Integrated MOSFET $R_{DS(on)}$	$I_{SW} = 500\text{ mA}$		0.19	0.43	Ω
$V_{FBTH-PWRGD}$	Power-Good FB pin threshold			2.25		V
V_{FB-OVP}	FB pin over-voltage protection threshold	V_{FB} rising, $V_{CDHC} = 4\text{V}$	2.64	2.76	2.88	V
	FB pin OVP hysteresis	V_{FB} falling	0.1	0.215	0.323	V
I_{FB}	Feedback pin input current	$V_{FB} = 3\text{V}$			1	μA
t_{on}	ON timer pulse width	$V_{IN} = 12\text{V}$, $V_{OUT} = 65\text{V}$, $R_{RT} = 300\text{ k}\Omega$		1460		ns
		$V_{IN} = 24\text{V}$, $V_{OUT} = 32.5\text{V}$, $R_{RT} = 300\text{ k}\Omega$		800		ns
		$V_{IN} = 12\text{V}$, $V_{OUT} = 65\text{V}$, $R_{RT} = 100\text{ k}\Omega$		550		ns
		$V_{IN} = 24\text{V}$, $V_{OUT} = 32.5\text{V}$, $R_{RT} = 100\text{ k}\Omega$		350		ns
$t_{on-min-ILIM}$	ON timer minimum pulse width at current limit			145		ns
t_{off}	OFF timer pulse width			145	350	ns
COMM PIN						
$V_{IOUT-OV}$	IOUT pin over-voltage threshold	COMM goes LOW during V_{IOUT} rising, other $V_{IOUT} = 1.2\text{V}$	5.6	6.7	7.8	V
$V_{COMM-LOW}$	COMM pin at LOW	5 mA into COMM			0.7	V
$I_{LEAK-FAULT}$	COMM pin Open Leakage	$V_{COMM} = 5\text{V}$			5	μA
Thermal Protection						
T_{OTM}	Over-temperature indication	T_J rising		135		$^{\circ}\text{C}$
$T_{OTM-HYS}$	Over-temperature indication hysteresis	T_J falling		15		$^{\circ}\text{C}$
T_{SD}	Thermal shutdown temperature	T_J rising		165		$^{\circ}\text{C}$
T_{SD-HYS}	Thermal shutdown temperature hysteresis	T_J falling		20		$^{\circ}\text{C}$

Note 1: Absolute Maximum Ratings are limits which damage to the device may occur. Operating ratings are conditions under which operation of the device is intended to be functional. For guaranteed specifications and test conditions, see the electrical characteristics. Thermal shutdown might occur within ambient operating temperature range as junction temperature rises above TSD level, customer should refer to efficiency data and thermal resistance data to estimate the junction temperature to ambient temperature delta.

Note 2: The human body model is a 100 pF capacitor discharged through a 1.5 k Ω resistor into each pin.

Note 3: The θ_{JA} is measured on a 4-layer standard JEDEC thermal test board with 12 vias, no air flow and 1W power dissipation. Thermal shutdown will occur if the junction temperature exceeds 165 $^{\circ}\text{C}$. The maximum power dissipation is a function of $T_{J(MAX)}$, θ_{JA} and T_A . The maximum allowable power dissipation at any ambient temperature is $PD = (T_{J(MAX)} - T_A) / \theta_{JA}$.

Note 4: V_{CC} provides self bias for the internal gate drive and control circuits. Device thermal limitations limit external loading.

Typical Performance Characteristics

Unless otherwise specified the following conditions apply: $T_J = 25^\circ\text{C}$, $V_{IN} = 12\text{V}$ with configuration in typical application circuit for $I_{LED} = 250\text{ mA}$ shown in this datasheet.

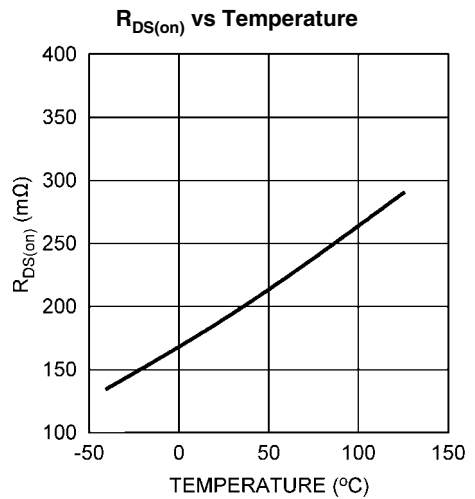
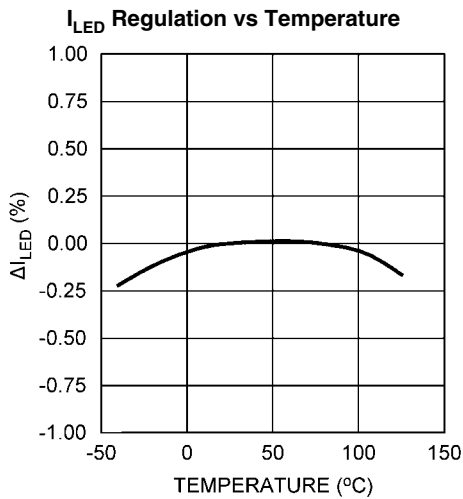
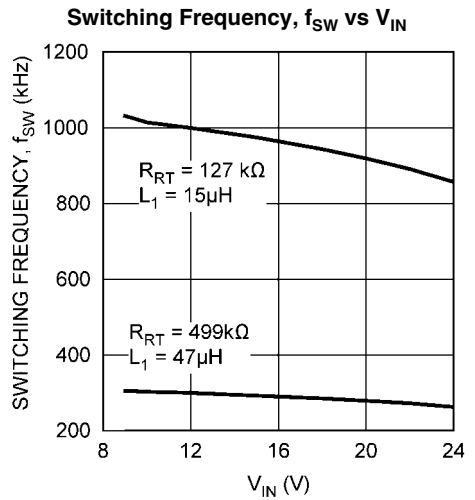
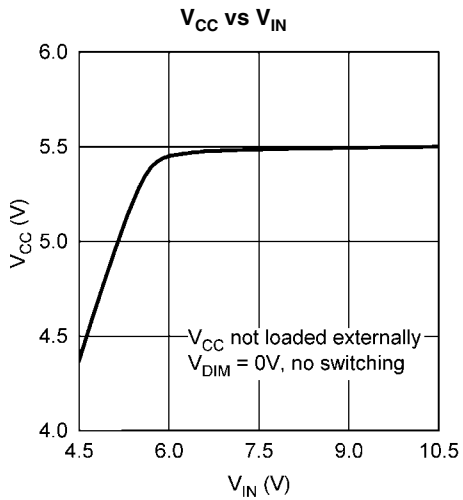
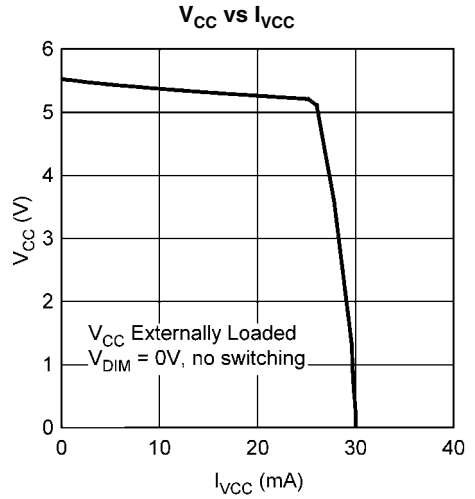
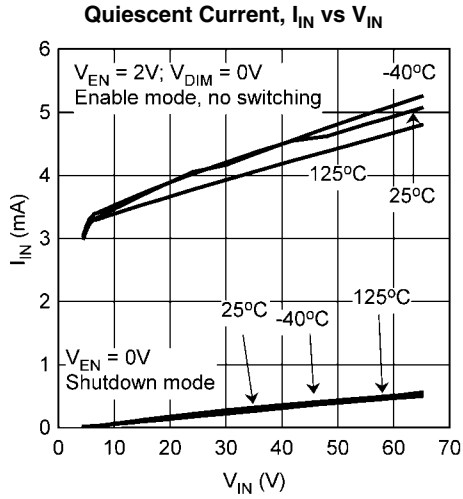

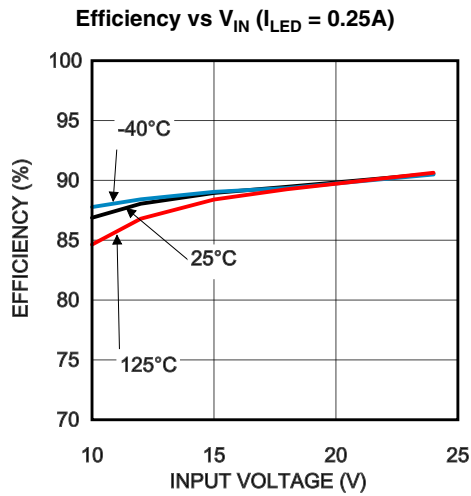

30170532

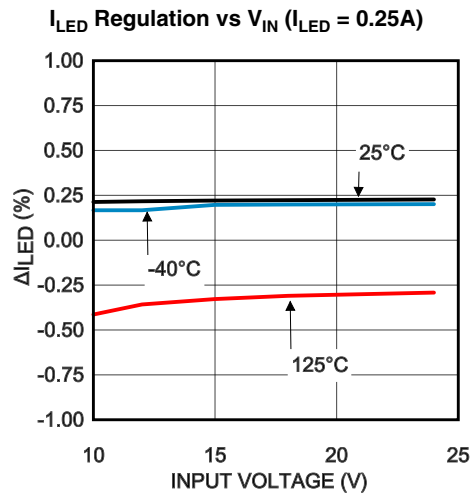

30170533

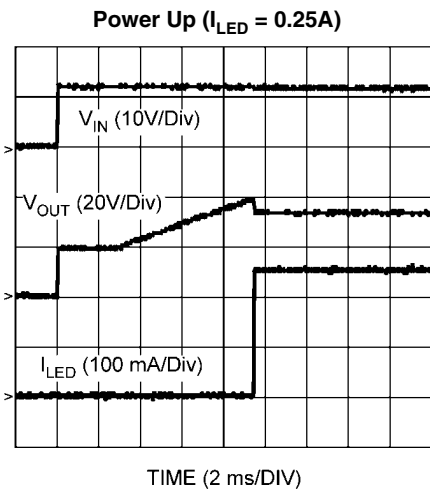

30170534

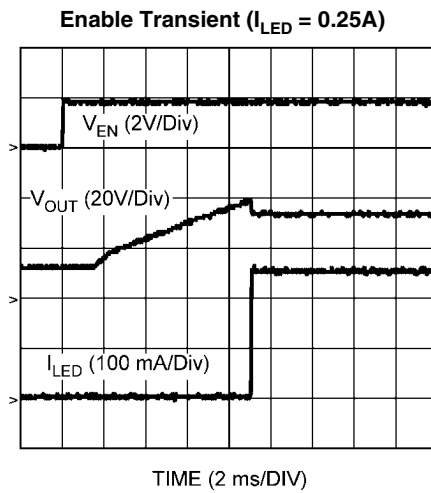

30170535

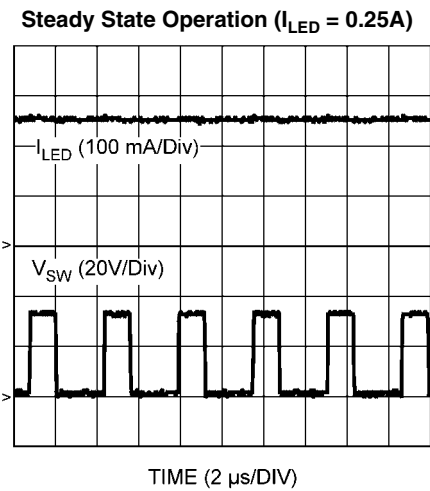

30170536

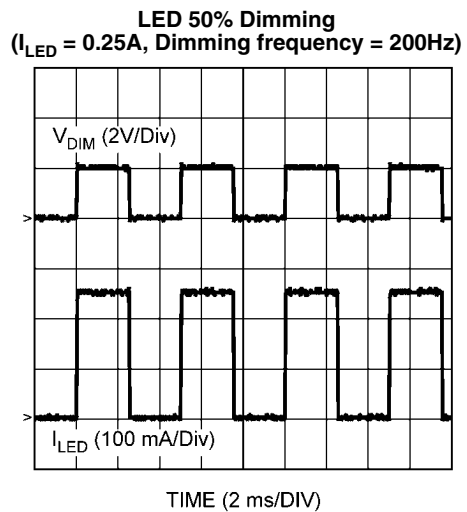

30170537

1000:1 LED Dimming
 ($I_{LED} = 0.25A$, Dimming frequency = 200Hz)

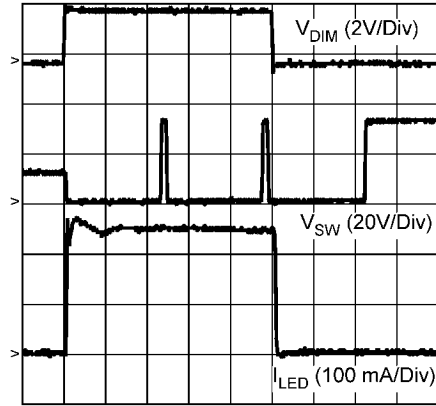

TIME (1 μ s/DIV)

30170538

10000:1 LED Dimming
 ($I_{LED} = 0.25A$, Dimming frequency = 200Hz)

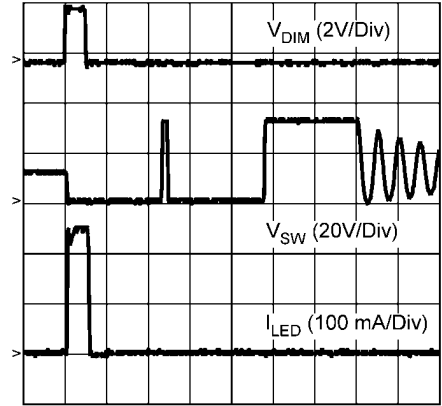

TIME (1 μ s/DIV)

30170539

Simplified Functional Block Diagram

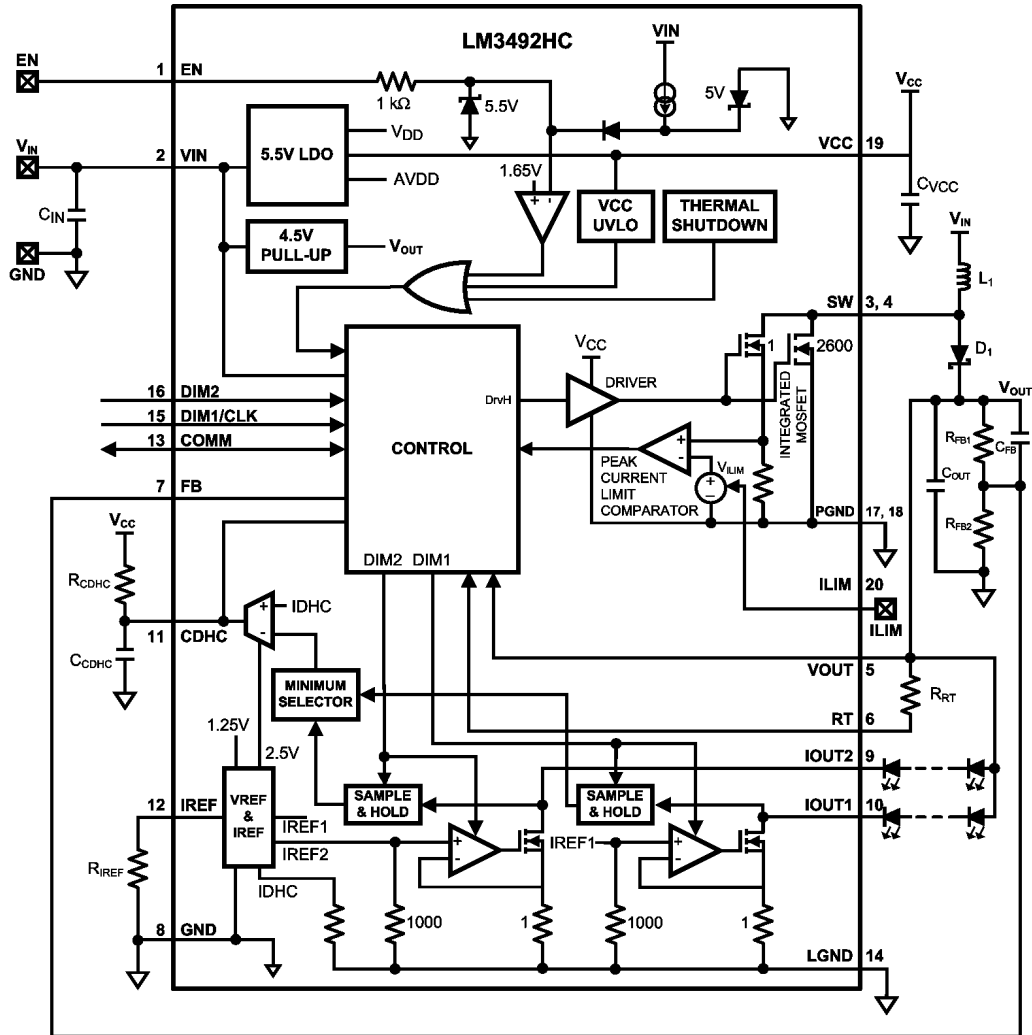

30170503

Overview

The LM3492HC integrates a boost converter and a two-channel current regulator to implement a high efficient and cost effective LED driver for driving two individually dimmable LED strings with a maximum power of 15W and an output voltage of up to 65V. The boost converter provides power for the LED strings, and the current regulator controls the dimming of the LED strings individually. The LM3492HC integrates an N-channel MOSFET switch and a two-channel current regulator in order to minimize the component count and solution size.

The boost converter of the LM3492HC employs a Projected On-Time (POT) control method to determine the on-time of the MOSFET with respect to the input and output voltages and an external resistor R_{RT} . During the on-period, the boost inductor is charged up, and the output capacitor is discharged to provide power to the output. A cycle-by-cycle current limit (which is 3.9A typically and programmable by an external resistor) is imposed on the MOSFET for protection. After the on-period, the MOSFET is turned off such that the boost inductor is discharged. The next on-period is started when the voltage of the FB pin is dropped below a threshold which is determined by Dynamic Headroom Control (DHC) and is ranged from 1.05V to 2.0V (DHC affects the threshold only when the DIM1 and/or DIM2 pins are high). The boost converter under POT control can maintain the switching frequency nearly constant so that the switching frequency depends on only R_{RT} [Figure 1](#). Also, POT control requires no compensation circuit and gives a fast transient response of the output voltage.

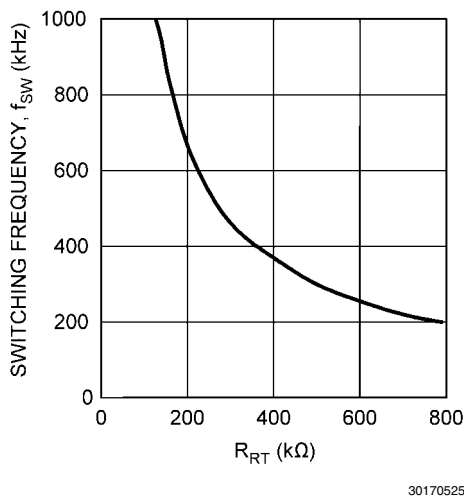

FIGURE 1. Switching Frequency

The two-channel current regulator of the LM3492HC is fast response so that it can allow very high contrast ratio of 10000:1. The two channels are dimmable individually. Channel 1 of the current regulator can be disabled by a digital command send through the COMM pin. In this case, the DIM1 pin can serve only as a clock signal for the data flow of the COMM pin. The power dissipated by the current regulator is adaptively minimized by Dynamic Headroom Control in order to maximize efficiency.

The LM3492HC can be applied in numerous applications like automotive LCD backlight panels. It can operate efficiently for inputs as high as 65V. Diagnostic functions including power good indication, over-temperature indication, IOUT over- and under-voltage indications facilitate the interface of the LM3492HC application circuit with external micro-processors

(MCUs). The LM3492HC will not latch off and continue to operate in the presence of the indications. Other useful features include thermal shutdown, VCC under-voltage lock-out, and precision enable. The LM3492HC is available in the thermally enhanced eTSSOP-20 package.

LDO Regulator

A 5.5V LDO regulator is integrated in the LM3492HC. For stability, an external capacitor C_{VCC} of more than 0.47 μ F should be connected between the VCC and GND pins. The current limit of the LDO is typically 30 mA. It can be used to pull-up the open-drain COMM pin with an external resistor, and inject current to the ILIM pin to adjust the current limit of the integrated MOSFET. When the voltage on the VCC pin (V_{CC}) is higher than the under-voltage lock-out (UVLO) threshold of 3.78V, the LM3492HC is enabled and the CDHC pin sources a current to charge up an external capacitor C_{CDHC} to provide a soft-start function.

Enable and Disable

To enable the LM3492HC, the voltage on the EN pin (V_{EN}) must be higher than an enable threshold of typically 1.63V. If V_{EN} is lower than 1.43V, the LM3492HC is shutdown. In this case, the LDO regulator is turned off and the CDHC pin is internally grounded. The EN pin is internally pulled up. After enable, the EN pin is pulled up by a 40 μ A current source. If the EN pin is connected to low such that the LM3492HC is shutdown, the pull-up current is reduced to 2 μ A. These take the advantages that the LM3492HC can effectively avoid false disabling by noise during operation, and minimize power consumption during shutdown. The enable threshold is precise such that it can be used to implement an UVLO function for the input voltage as shown in [Figure 2](#). The input voltage can be connected to the EN pin through a resistor divider consists of R_{EN1} and R_{EN2} . This can ensure that the LM3492HC is operated after the input voltage reaches a minimum require value $V_{IN(EN)}$, which can be calculated by the following equation:

$$V_{IN(EN)} = 1.63V(1 + R_{EN1}/R_{EN2}) \quad (1)$$

A zener diode D_{EN} should be placed between the EN and GND pins to keep V_{EN} below its absolute maximum caused by the increase of the input voltage.

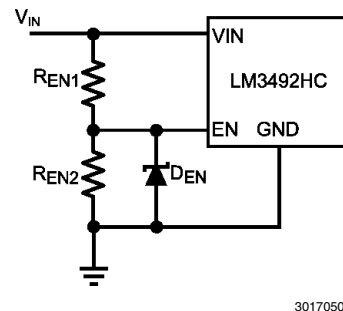

FIGURE 2. Input Voltage UVLO Implemented by Precision Enable

Once the EN pin is pulled low, the LM3492HC will perform the following functions: reset IOUT over- and under-voltage indications and the corresponding COMM bit pattern, resume the switching frequency tuning to the normal frequency, and resume channel 1 of the current regulator if it is disabled. Pulling the EN pin low for a short period of about 200 ns can achieve

the above functions with nearly no effect on the operation of the boost converter and the current regulator.

Current Limit

The current limit I_{CL} of the integrated MOSFET of the LM3492HC provides a cycle-by-cycle current limit for protection. It can be decreased by injecting a small signal current I_{ILIM} into the ILIM pin, and the relationship between I_{CL} and I_{ILIM} is

$$I_{CL} = I_{CL(MAX)} - 4290 I_{ILIM} \quad (2)$$

where $I_{CL(MAX)}$ is the maximum current limit. Its typical value is 3.9A. As shown in [Figure 3](#), I_{ILIM} can be provided by connecting a resistor R_{ILIM} from the VCC pin to the ILIM pin. The typical voltage on the ILIM pin is 0.7V. To obtain the maximum current limit, connect the ILIM pin to the ground.

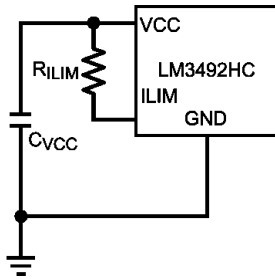

30170505

FIGURE 3. Programmable Current Limit

Thermal Protection

Thermal protection is implemented by an internal thermal shutdown circuit, which activates at 165°C (typically) to disable the LM3492HC. In this case, the LDO regulator is turned off and the CDHC pin is internally grounded. Thermal protection helps prevent catastrophic failures from accidental device overheating. When the junction temperature of the LM3492HC falls back below 145°C (typical hysteresis = 20°C), the LM3492HC resumes normal operation.

Dynamic Headroom Control, Over-riding, and Soft-start

Dynamic headroom control (DHC) is implemented in the LM3492HC to adjust the output voltage V_{OUT} of the boost converter in order to reduce the power loss of the current regulator to maximize efficiency. Let $V_{LED,n}$ and $V_{IOUT,n}$ be the forward voltage of an LED string connecting to the IOUTn pin and the voltage of the IOUTn pin, where n is 1, 2 for channels 1, 2 of the current regulator. Since $V_{LED,n}$ is normally decreasing gradually (in terms of minutes) owing to the rise of LED die temperature during operation, DHC adjust V_{OUT} by adjusting a threshold which is reflected on the voltage of the FB pin with reference to $V_{IOUT,n}$, which is the difference between V_{OUT} and $V_{LED,n}$. The sensitivity of DHC, which is the response time on adjusting V_{OUT} , is set by C_{CDHC} . If C_{CDHC} is small, V_{OUT} is more sensitive to the variation of $V_{LED,n}$.

DHC over-riding can be implemented by internal pull-up or external pull-up (by connecting the CDHC and VCC pins with a resistor, e.g. 10 M Ω). In this case, the voltage of the CDHC pin will rise over 2.5V, and the voltage of the FB pin will rise until over-voltage protection is hit. Since the pull-up is weak, DHC over-riding will occur only at low contrast ratio (e.g. <1%).

During startup, the voltage of the CDHC pin is risen from 0V to 2.25V at a speed depends on C_{CDHC} . This makes the voltage of the FB pin as well as the output voltage ramps up in a controlled manner, and effectively a soft-start function is implemented. The soft-start can be programmable by the C_{CDHC} .

An internal switch grounds the CDHC pin if any of the following cases happens: (i) V_{CC} is below the VCC UVLO threshold; (ii) a thermal shutdown occurs; or (iii) the EN pin is pulled low. The CDHC pin cannot be connected to the ground externally.

Current Regulator

The LM3492HC integrates a two-channel current regulator for controlling the current of two LED strings. The two LED strings are dimmable individually by dimming signals applied to the DIM1 and DIM2 pins for LED strings 1 and 2, which are connected from the VOUT pin to the IOUT1 and IOUT2 pins. The DIM1 and DIM2 pins are internally pulled low. The lowest contrast ratio is 10000:1. The finest pulse width of the dimming signal for the DIM1 and DIM2 pins is 300 ns.

The current of an LED string (I_{LED}) is programmable from 50 mA to 250 mA by an external resistor R_{IREF} connecting from the IREF pin to the ground. The relationship between I_{LED} and R_{IREF} is shown in [Figure 4](#). The two channels of the current regulator can work in parallel for only one LED string by connecting the IOUT1 and IOUT2 pins together to provide an LED current of up to 500 mA. In this case, the DIM1 and DIM2 pins should also be connected together.

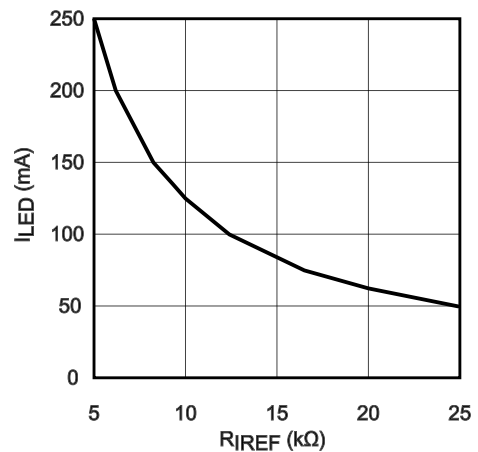

30170531

FIGURE 4. I_{LED} vs R_{IREF}

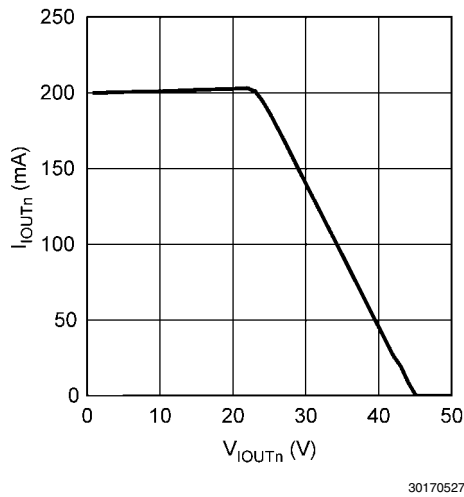

FIGURE 5. Over-power Protection

If the voltage on the IOUTn (n = 1, 2) pin is over 24V when channel n is on, the regulated current of channel n will be reduced linearly if the voltage further increases (as shown in Figure 5). The regulated current of another channel is not affected. This over-power protection feature avoids damaging the current regulator owing to the shorting of many LEDs in one string.

Output Voltage Feedback

The output voltage is fed back to the FB pin through a feedback circuit consists of R_{FB1} , R_{FB2} , and C_{FB} as shown in Figure 6. The value of C_{FB} is recommended to be 10 pF. In order to help feed the AC component of the output voltage back. The DC component of the output voltage is fed back by R_{FB1} and R_{FB2} . The voltage of the FB pin V_{FB} can be adjusted by DHC. When V_{FB} reaches V_{FB-OVP} , the maximum output voltage of the boost converter $V_{OUT(MAX)}$ reaches its maximum, and it is calculated as follows:

$$V_{OUT(MAX)} = 2.88V (1 + R_{FB1}/R_{FB2}) \quad (3)$$

Under DHC, the output voltage should be maintained at a nominal voltage but not the maximum. The nominal output voltage ($V_{OUT(NOM)}$) is

$$V_{OUT(NOM)} = \max(V_{LED,n} + V_{IOUT,n}), n = 1, 2 \quad (4)$$

where $V_{LED,n}$ is the forward voltage of LED string n and $V_{IOUT,n}$ is the voltage of the IOUTn pin, where n is 1, 2 for channels 1, 2 of the current regulator). The minimum value of $V_{IOUT,n}$ is about $5\Omega \times I_{LED}$. It is recommended that the nominal voltage of the FB pin ($V_{FB(NOM)}$) is between 1.05V to 2V. Hence, the equation relating $V_{OUT(MAX)}$, $V_{OUT(NOM)}$, and $V_{FB(NOM)}$ is as follows:

$$V_{OUT(MAX)} = V_{OUT(NOM)} \times 2.88V / V_{FB(NOM)} \quad (5)$$

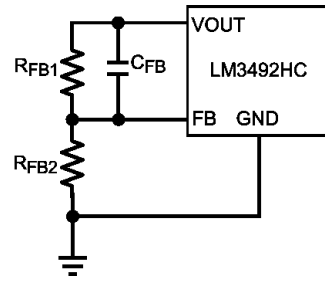

30170506

FIGURE 6. Output Voltage Feedback Circuit

Over-Voltage Protection

When V_{FB} is higher than the FB pin over-voltage protection (OVP) threshold V_{FB-OVP} (typically 2.76V and maximum 2.88V), the on-period of the integrated MOSFET stop immediately, and the MOSFET keeps off until V_{FB} falls back below 2.545V (typical hysteresis 0.215V).

An alternative method to implement OVP is to directly monitor V_{OUT} instead of V_{FB} . An external circuit as shown in Figure 7 is required. Current is injected to the ILIM pin to drive the LM3492HC to the current limit mode once V_{OUT} is higher than the avalanche voltage of the zener diode D_{OVP} plus 0.7V, the typical voltage on the ILIM pin. In this case, a maximum limit of V_{OUT} is imposed. However, at the maximum limit of V_{OUT} , V_{FB} should be higher than 2.25V to avoid affecting the startup of the LM3492HC.

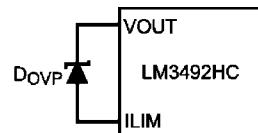

30170530

FIGURE 7. External OVP circuit

Bi-Directional Communication Pin

The COMM pin of the LM3492HC is an open-drain bi-directional I/O pin for interfacing with an external MCU for the following functions: power-good indication, over-temperature indication, IOUT over- and under-voltage indications, switching frequency tuning, and channel 1 disabling. Except the power good indication and the over-temperature alert, all data flow through the COMM pin is serial and is latched by the falling edge of the signal applying to the DIM1 pin, even when channel 1 of the current regulator is disabled. If the DIM1 pin stays only low or only high, either by an external circuit or letting it open and pull low internally, data flow will not occur. Figure 8 and Figure 9 show a timing diagram of reading and writing a bit from and to the LM3492HC through the COMM pin.

The COMM pin should be pull-up by an MCU I/O pin which has pull-up capability, or an external resistor R_{COMM} to the VCC pin. Otherwise, the voltage of the COMM pin will remain at zero. The rise time of the output signal of the COMM pin depends on the pull-up power. If the rise time is long (R_{COMM} is too large or pull-up power from the connecting MCU I/O pin is too weak), data may be ready after a longer duration after the falling edge. In this case, a longer delay between the falling edge latching and the (input or output) bit is required.

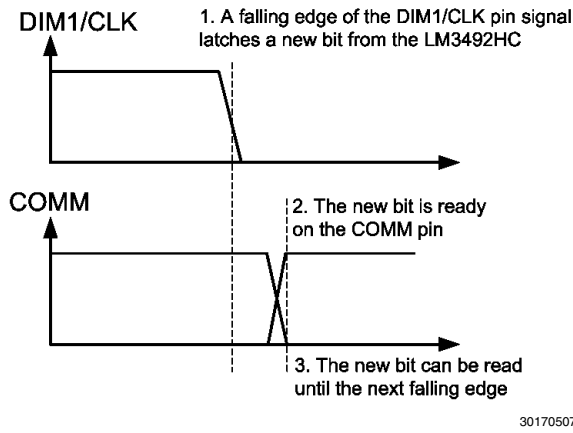

FIGURE 8. Read from the COMM Pin

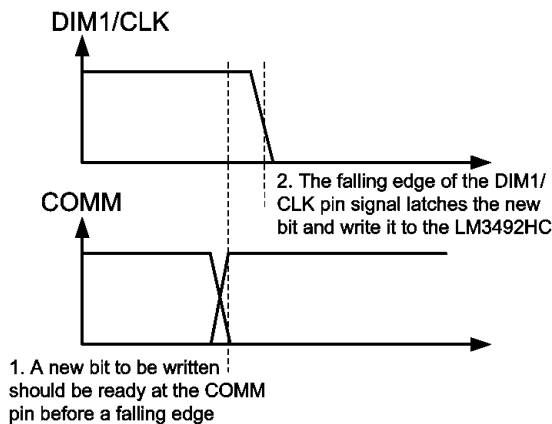

FIGURE 9. Write to the COMM Pin

POWER-GOOD INDICATION

Upon startup, the COMM pin reads low. The output voltage of the boost converter of the LM3492HC will rise until the voltage on the FB pin (V_{FB}) reaches 2.25V, when the COMM pin reads high to indicate power-good. The power-good indication is independent of the signal applied on the DIM1 pin.

OVER-TEMPERATURE INDICATION

If the junction temperature of the LM3492HC reaches 135°C, the COMM pin reads low, showing an over-temperature indication. External MCU should consider to turn off or reduce the brightness of the LED strings in order to prevent over-temperature. The over-temperature indication is independent of the signal applied on the DIM1 pin. The COMM pin reads high if the junction temperature falls below 120°C. The LM3492HC will not latch off and continue to operate in the presence of the over-temperature indication.

IOUT UNDER-VOLTAGE INDICATION

The LM3492HC gives an IOUTn ($n = 1, 2$) under-voltage indication if the voltage of the IOUTn pin when DIMn is high is lower than its minimum required voltage which can regulate I_{LED} , and the voltage of the CDHC pin reaches its maximum, and these conditions last for 508 consecutively dimming signals applied on the DIMn pin. This means that the current of the LED string n does not reach its regulated value. In most case, the IOUT under-voltage indication can be regarded as an open fault of the LED string n. A bit pattern (refer to table

1) can be read from the COMM pin. The LM3492HC will not latch off and continue to operate in the presence of the IOUT under-voltage indication.

IOUT OVER-VOLTAGE INDICATION

The LM3492HC gives an IOUTn ($n = 1, 2$) over-voltage indication if the voltage of the IOUTn pin when DIMn is high is higher than a threshold of typically 6.5V, and the condition lasts for 508 consecutively dimming signals applied on the DIMn pin. The IOUT over-voltage indication can be regarded as a short fault of the LED string n except the following 2 cases: i) powering up the LM3492HC at a very low dimming ratio such that V_{OUT} maintains at a maximum and DHC is not fast enough to reduce V_{OUT} ; ii) under DHC over-riding. A bit pattern (refer to table 1) can be read from the COMM pin. The LM3492HC will not latch off and continue to operate in the presence of the IOUT over-voltage indication.

TABLE 1. COMM Bit Patterns

Indication	COMM Bit Pattern
IOUT1 over-voltage indication	0001
IOUT2 over-voltage indication	0011
IOUT1 under-voltage indication	0101
IOUT2 under-voltage indication	0111

COMM BIT PATTERN

Table 1 summarized all COMM bit patterns of IOUT over- and under-voltage indications. A bit pattern can be read from the COMM pin continuously even the condition causing IOUT over- and under-voltage disappeared. An existing COMM bit pattern will be clear if one of the following condition occurs:

- the LM3492HC is shutdown;
- the LM3492HC is disabled by pulling the EN pin low;
- the over-temperature indication is appearing.

To clear the COMM bit pattern without affecting the operation of the boost converter and the current regulator, a reset signal which pulls the EN pin low for about 200 ns can be applied. In this case, the COMM pin will not give bit pattern any more unless a condition causing IOUT over- or under-voltage appears and lasts for 508 consecutively dimming signals.

If an external MCU is used to read the COMM bit pattern, it is recommended that a reset signal should be send to clear the COMM bit pattern after the bit pattern is read. This can avoid that the existing COMM bit pattern is overwritten by another pattern appeared in a later time.

In case of over-temperature, the COMM pin will be pulled low to give an over-temperature indication disregard of any existing COMM bit pattern. After that the over-temperature indication disappears, the COMM bit pattern appeared before the over-temperature indication will appear again.

SWITCHING FREQUENCY TUNING

After power good, the switching frequency (f_{SW}) of the LM3492HC can be tuned down 20% or 40%, or resume normal by writing commands (refer to table 2) to the COMM pin. This helps avoid interfering some sensitive devices, for example radios, working nearby the LM3492HC. Upon reset, f_{SW} of the LM3492HC will resume normal by default. If the over-temperature indication or any COMM bit pattern has al-

ready presented, no command can be written to the LM3492HC.

CHANNEL 1 DISABLE

After power good, channel 1 of the current regulator can be disabled by writing a command (refer to table 2) to the COMM pin. If LED string 1 is malfunctioning, channel 1 can be disabled and the signal applied on the DIM1 pin can serve as only a clock signal for the data flow of the COMM pin. Channel 1 is by default enabled after reset. If the over-temperature indication or any COMM bit pattern has already presented, no command can be written to the LM3492HC.

TABLE 2. Commands

Command	Command Bit Pattern
f _{SW} resume normal	1111011101110111
f _{SW} tune down by 20%	1111000100010001
f _{SW} tune down by 40%	1111001100110011
Channel 1 disable	1111010101010101

Application Information

EXTERNAL COMPONENTS

The following procedures are to design an LED driver using the LM3492HC with an input voltage ranged from 10V to 24V and two LED strings consists of 10 LEDs each with a forward voltage of 3V for each LED when running at 250 mA. The output power is 15W. The switching frequency f_{SW} is designed to be 300 kHz.

R_{FB1}, R_{FB2}, and C_{FB}: The nominal voltage of the LED string with 10 LEDs is 30V, and the minimum voltage of the IOUTn pin (n = 1, 2) is 1.25V when I_{LED} is 250 mA. As a result, V_{OUT}(NOM) is 31.25V. Design V_{OUT}(MAX) to be 50V. From (5), V_{FB}(NOM) is about 1.8V, which falls in the recommended operation range from 1.05V to 2V. Also, design R_{FB2} to be 16.2 kΩ. From (3), R_{FB1} is calculated to be 265.1 kΩ, and a standard resistor value of 261 kΩ is selected. C_{FB} is selected to be 10 pF as recommended.

L₁: The main parameter affected by the inductor is the peak to peak inductor current ripple (I_{LR}). To maintain a continuous conduction mode (CCM) operation, the average inductor current I_{L1} should be larger than half of I_{LR}. For a boost converter, I_{L1} equals to the input current I_{IN}. Hence,

$$I_{IN} = (V_{OUT(NOM)} \times 2I_{LED}) / V_{IN} \quad (6)$$

Also,

$$t_{on} = (1 - V_{IN}/V_{OUT}) / f_{SW} \quad (7)$$

$$L_1 = (V_{IN} \times t_{on}) / 2I_{IN} \quad (8)$$

If V_{IN} is maximum, which is 24V in this example, and only one LED string is turned on (since the two channels of the LM3492HC are individually dimmable), I_{IN} is minimum. From (6)-(8), it can be calculated that I_{IN(MIN)}, t_{on}, and L₁ are 0.326A, 0.77 μs, and 28.5 μH. On the other hand, from (6), I_{IN} is maximum when V_{IN} is minimum, which is 10V in this example, and the two LED strings are turned on together. Hence I_{IN(MAX)} is 1.56A. Then, I_{LR} is

$$I_{LR} = (V_{IN} \times t_{on}) / L_1 \quad (9)$$

From (7), t_{on} is 2.27 μs. From (9), I_{LR} is 0.80A. The steady state peak inductor current I_{L1(PEAK)} is

$$I_{L1(PEAK)} = I_{L1} + I_{LR} / 2 \quad (10)$$

As a result, I_{L1(PEAK)} is 1.96A. A standard value of 27 μH is selected for L₁, and its saturation current is larger than 1.96A.

D₁: The selection of the boost diode D₁ depends on two factors. The first factor is the reverse voltage, which equals to V_{OUT} for a boost converter. The second factor is the peak diode current at the steady state, which equals to the peak inductor current as shown in (10). In this example, a 100V 3A schottky diode is selected.

C_{IN} and C_{OUT}: The function of the input capacitor C_{IN} and the output capacitor C_{OUT} is to reduce the input and output voltage ripples. Experimentation is usually necessary to determine their value. The rated DC voltage of capacitors used should be higher than the maximum DC voltage applied. Owing to the concern of product lifetime, ceramic capacitors are recommended. But ceramic capacitors with high rated DC voltage and high capacitance are rare in general. Multiple capacitors connecting in parallel can be used for C_{IN} and C_{OUT}. In this example, two 10 μF ceramic capacitor are used for C_{IN}, and two 2.2 μF ceramic capacitor are used for C_{OUT}.

C_{VCC}: The capacitor on the VCC pin provides noise filtering and stabilizes the LDO regulator. It also prevents false triggering of the VCC UVLO. C_{VCC} is recommended to be a 1 μF good quality and low ESR ceramic capacitor.

C_{CDHC}: The capacitor at the CDHC pin not only affects the sensitivity of the DHC but also determines the soft-start time t_{SS}, i.e. the time for the output voltage to rise until power good. t_{SS} is determined from the following equation:

$$t_{SS} = \frac{C_{CDHC} \times 2.25V}{120 \mu A}$$

In this example, C_{CDHC} is recommended to be a 0.47 μF good quality and low ESR ceramic capacitor.

R_{RT} and R_{REF}: The resistors R_{RT} and R_{REF} set the switching frequency f_{SW} of the boost converter and the LED current I_{LED} respectively. From Figure 1, if f_{SW} is 300 kHz, R_{RT} is selected to be 499 kΩ. From Figure 4, if I_{LED} is 250 mA, R_{REF} is selected to be 4.99 kΩ.

R_{COMM}: Since the COMM pin is open drain, a resistor R_{COMM} of 52.3 kΩ is used to connect the VCC and COMM pins to act as a pull-up function.

PC Board Layout

The layout of the printed circuit board is critical in order to optimize the performance of the LM3492HC application circuit. In general, external components should be placed as close to the LM3492HC and each other as possible in order to make copper traces short and direct. In particular, components of the boost converter C_{IN}, L₁, D₁, C_{OUT}, and the LM3492HC should be closed. Also, the output feedback capacitor C_{FB} should be closed to the output capacitor C_{OUT}. The ground plane connecting the GND, PGND, and LGND pins and the exposed pad of the LM3492HC and the ground connection of the C_{IN} and C_{OUT} should be placed on the same copper layer.

Good heat dissipation helps optimize the performance of the LM3492HC. The ground plane should be used to connect the exposed pad of the LM3492HC, which is internally connected to the LM3492HC die substrate. The area of the ground plane should be extended as much as possible on the same copper layer around the LM3492HC. Using numerous vias beneath the exposed pad to dissipate heat of the LM3492HC to another copper layer is also a good practice.

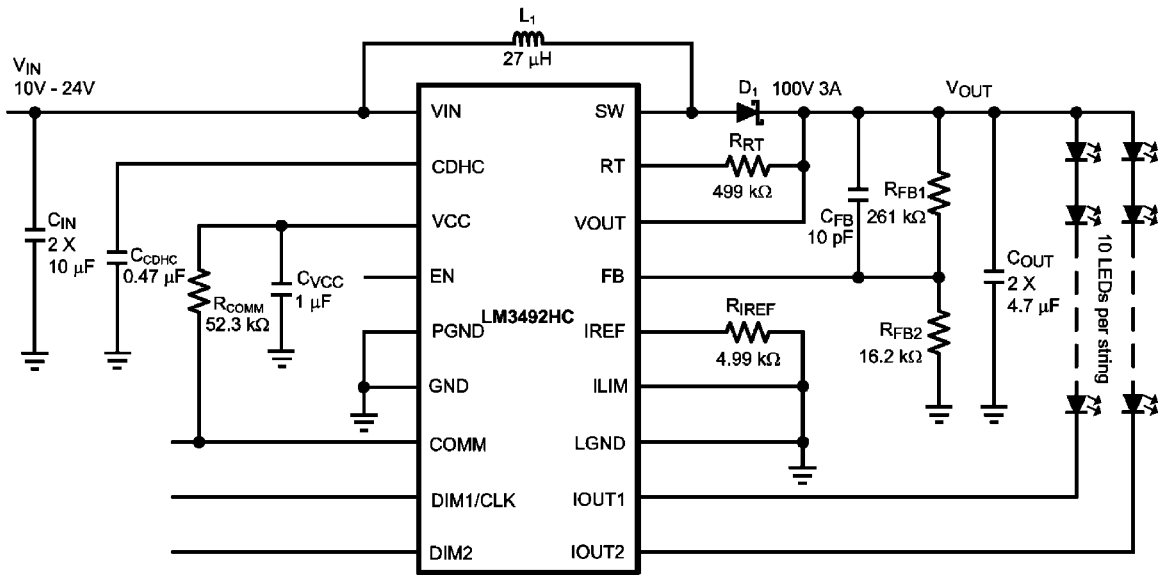

30170529

Physical Dimensions inches (millimeters) unless otherwise noted

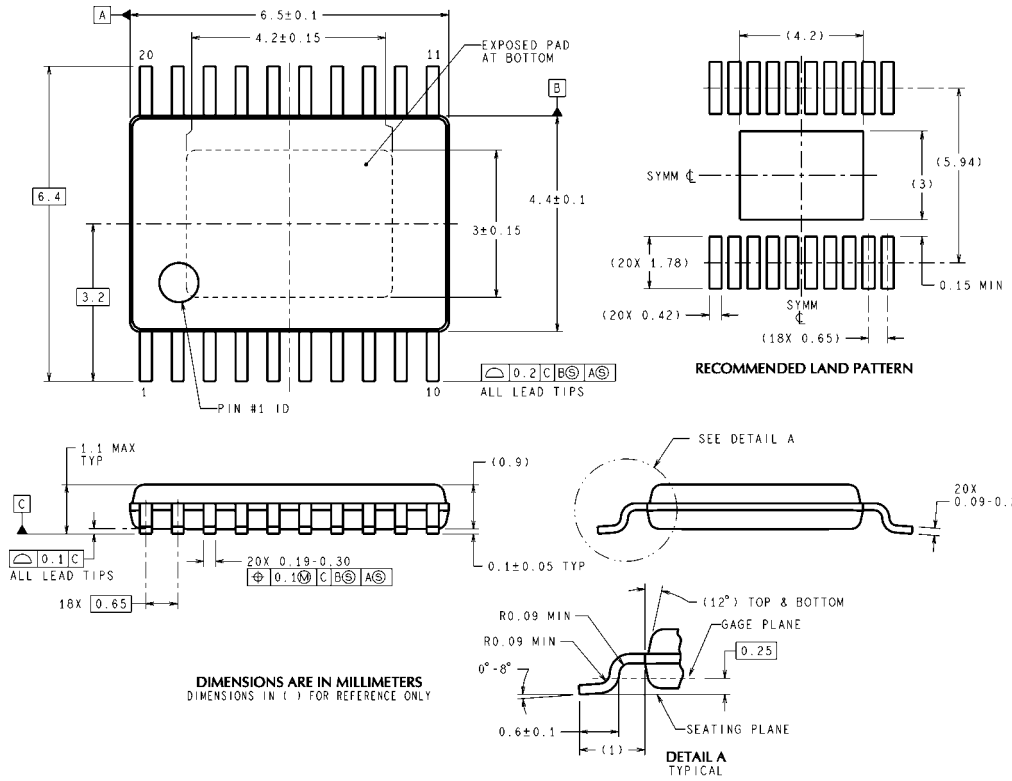

20-Lead Plastic eTSSOP Package
NS Package Number MXA20A

MXA20A (Rev C)

Notes

IMPORTANT NOTICE

Texas Instruments Incorporated and its subsidiaries (TI) reserve the right to make corrections, modifications, enhancements, improvements, and other changes to its products and services at any time and to discontinue any product or service without notice. Customers should obtain the latest relevant information before placing orders and should verify that such information is current and complete. All products are sold subject to TI's terms and conditions of sale supplied at the time of order acknowledgment.

TI warrants performance of its hardware products to the specifications applicable at the time of sale in accordance with TI's standard warranty. Testing and other quality control techniques are used to the extent TI deems necessary to support this warranty. Except where mandated by government requirements, testing of all parameters of each product is not necessarily performed.

TI assumes no liability for applications assistance or customer product design. Customers are responsible for their products and applications using TI components. To minimize the risks associated with customer products and applications, customers should provide adequate design and operating safeguards.

TI does not warrant or represent that any license, either express or implied, is granted under any TI patent right, copyright, mask work right, or other TI intellectual property right relating to any combination, machine, or process in which TI products or services are used. Information published by TI regarding third-party products or services does not constitute a license from TI to use such products or services or a warranty or endorsement thereof. Use of such information may require a license from a third party under the patents or other intellectual property of the third party, or a license from TI under the patents or other intellectual property of TI.

Reproduction of TI information in TI data books or data sheets is permissible only if reproduction is without alteration and is accompanied by all associated warranties, conditions, limitations, and notices. Reproduction of this information with alteration is an unfair and deceptive business practice. TI is not responsible or liable for such altered documentation. Information of third parties may be subject to additional restrictions.

Resale of TI products or services with statements different from or beyond the parameters stated by TI for that product or service voids all express and any implied warranties for the associated TI product or service and is an unfair and deceptive business practice. TI is not responsible or liable for any such statements.

TI products are not authorized for use in safety-critical applications (such as life support) where a failure of the TI product would reasonably be expected to cause severe personal injury or death, unless officers of the parties have executed an agreement specifically governing such use. Buyers represent that they have all necessary expertise in the safety and regulatory ramifications of their applications, and acknowledge and agree that they are solely responsible for all legal, regulatory and safety-related requirements concerning their products and any use of TI products in such safety-critical applications, notwithstanding any applications-related information or support that may be provided by TI. Further, Buyers must fully indemnify TI and its representatives against any damages arising out of the use of TI products in such safety-critical applications.

TI products are neither designed nor intended for use in military/aerospace applications or environments unless the TI products are specifically designated by TI as military-grade or "enhanced plastic." Only products designated by TI as military-grade meet military specifications. Buyers acknowledge and agree that any such use of TI products which TI has not designated as military-grade is solely at the Buyer's risk, and that they are solely responsible for compliance with all legal and regulatory requirements in connection with such use.

TI products are neither designed nor intended for use in automotive applications or environments unless the specific TI products are designated by TI as compliant with ISO/TS 16949 requirements. Buyers acknowledge and agree that, if they use any non-designated products in automotive applications, TI will not be responsible for any failure to meet such requirements.

Following are URLs where you can obtain information on other Texas Instruments products and application solutions:

Products

Audio	www.ti.com/audio
Amplifiers	amplifier.ti.com
Data Converters	dataconverter.ti.com
DLP® Products	www.dlp.com
DSP	dsp.ti.com
Clocks and Timers	www.ti.com/clocks
Interface	interface.ti.com
Logic	logic.ti.com
Power Mgmt	power.ti.com
Microcontrollers	microcontroller.ti.com
RFID	www.ti-rfid.com
OMAP Mobile Processors	www.ti.com/omap
Wireless Connectivity	www.ti.com/wirelessconnectivity

Applications

Automotive and Transportation	www.ti.com/automotive
Communications and Telecom	www.ti.com/communications
Computers and Peripherals	www.ti.com/computers
Consumer Electronics	www.ti.com/consumer-apps
Energy and Lighting	www.ti.com/energy
Industrial	www.ti.com/industrial
Medical	www.ti.com/medical
Security	www.ti.com/security
Space, Avionics and Defense	www.ti.com/space-avionics-defense
Video and Imaging	www.ti.com/video

TI E2E Community Home Page

e2e.ti.com

Mailing Address: Texas Instruments, Post Office Box 655303, Dallas, Texas 75265
Copyright © 2012, Texas Instruments Incorporated