



T-46-07-08

74

# 5474/DM5474/DM7474

## Dual Positive-Edge-Triggered D Flip-Flops with Preset, Clear and Complementary Outputs

### General Description

This device contains two independent positive-edge-triggered D flip-flops with complementary outputs. The information on the D input is accepted by the flip-flops on the positive going edge of the clock pulse. The triggering occurs at a voltage level and is not directly related to the transition time of the rising edge of the clock. The data on the D input may be changed while the clock is low or high without affecting the outputs as long as the data setup and hold times are not

violated. A low logic level on the preset or clear inputs will set or reset the outputs regardless of the logic levels of the other inputs.

### Features

- Alternate Military/Aerospace device (5474) is available. Contact a National Semiconductor Sales Office/Distributor for specifications.

### Connection Diagram

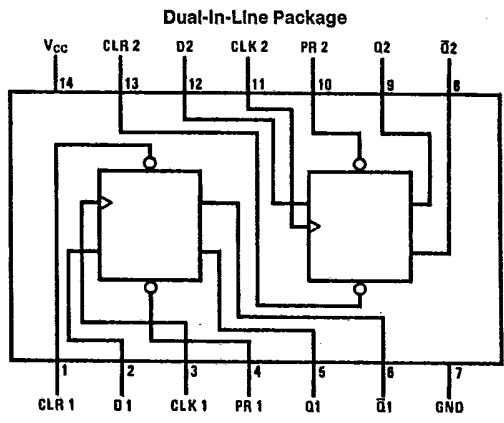

TL/F/6526-1

Order Number 5474DMQB, 5474FMQB, DM5474J, DM5474W, DM7474M or DM7474N  
See NS Package Number J14A, M14A, N14A or W14B

### Function Table

Inputs				Outputs	
PR	CLR	CLK	D	Q	$\bar{Q}$
L	H	X	X	H	L
H	L	X	X	L	H
L	L	X	X	H*	H*
H	H	↑	H	H	L
H	H	↑	L	L	H
H	H	L	X	Q <sub>0</sub>	$\bar{Q}$ <sub>0</sub>

H = High Logic Level  
 X = Either Low or High Logic Level  
 L = Low Logic Level  
 ↑ = Positive-going transition of the clock.  
 \* = This configuration is nonstable; that is, it will not persist when either the preset and/or clear inputs return to their inactive (high) level.  
 Q<sub>0</sub> = The output logic level of Q before the indicated input conditions were established.



T-46-07-08

**Absolute Maximum Ratings** (Note)

If Military/Aerospace specified devices are required, please contact the National Semiconductor Sales Office/Distributors for availability and specifications.

Supply Voltage	7V
Input Voltage	5.5V
Operating Free Air Temperature Range	
DM54 and 54	-55°C to +125°C
DM74	0°C to +70°C
Storage Temperature Range	-65°C to +150°C

Note: The "Absolute Maximum Ratings" are those values beyond which the safety of the device cannot be guaranteed. The device should not be operated at these limits. The parametric values defined in the "Electrical Characteristics" table are not guaranteed at the absolute maximum ratings. The "Recommended Operating Conditions" table will define the conditions for actual device operation.

**Recommended Operating Conditions**

Symbol	Parameter	DM5474			DM7474			Units
		Min	Nom	Max	Min	Nom	Max	
V <sub>CC</sub>	Supply Voltage	4.5	5	5.5	4.75	5	5.25	V
V <sub>IH</sub>	High Level Input Voltage	2			2			V
V <sub>IL</sub>	Low Level Input Voltage			0.8			0.8	V
I <sub>OH</sub>	High Level Output Current			-0.4			-0.4	mA
I <sub>OL</sub>	Low Level Output Current			16			16	mA
f <sub>CLK</sub>	Clock Frequency (Note 2)	0		15	0		15	MHz
t <sub>w</sub>	Pulse Width (Note 2)	Clock High	30		30			ns
		Clock Low	37		37			
		Clear Low	30		30			
		Preset Low	30		30			
t <sub>SU</sub>	Input Setup Time (Notes 1 & 2)	20 ↑			20 ↑			ns
t <sub>H</sub>	Input Hold Time (Notes 1 & 2)	5 ↑			5 ↑			ns
T <sub>A</sub>	Free Air Operating Temperature	-55		125	0		70	°C

Note 1: The symbol (↑) indicates the rising edge of the clock pulse is used for reference.

Note 2: T<sub>A</sub> = 25°C and V<sub>CC</sub> = 5V.

**Electrical Characteristics** over recommended operating free air temperature range (unless otherwise noted)

Symbol	Parameter	Conditions	Min	Typ (Note 3)	Max	Units
V <sub>I</sub>	Input Clamp Voltage	V <sub>CC</sub> = Min, I <sub>I</sub> = -12 mA			-1.5	V
V <sub>OH</sub>	High Level Output Voltage	V <sub>CC</sub> = Min, I <sub>OH</sub> = Max V <sub>IL</sub> = Max, V <sub>IH</sub> = Min	2.4	3.4		V
V <sub>OL</sub>	Low Level Output Voltage	V <sub>CC</sub> = Min, I <sub>OL</sub> = Max V <sub>IH</sub> = Min, V <sub>IL</sub> = Max		0.2	0.4	V
I <sub>I</sub>	Input Current @ Max Input Voltage	V <sub>CC</sub> = Max, V <sub>I</sub> = 5.5V			1	mA
I <sub>IH</sub>	High Level Input Current	V <sub>CC</sub> = Max V <sub>I</sub> = 2.4V	D		40	μA
			Clock		80	
			Clear		120	
			Preset		40	
I <sub>IL</sub>	Low Level Input Current	V <sub>CC</sub> = Max V <sub>I</sub> = 0.4V (Note 6)	D		-1.6	mA
			Clock		-3.2	
			Clear		-3.2	
			Preset		-1.6	
I <sub>OS</sub>	Short Circuit Output Current	V <sub>CC</sub> = Max (Note 4)	DM54	-20	-55	mA
			DM74	-18	-55	
I <sub>CC</sub>	Supply Current	V <sub>CC</sub> = Max (Note 5)		17	30	mA

Note 3: All typicals are at V<sub>CC</sub> = 5V, T<sub>A</sub> = 25°C.

Note 4: Not more than one output should be shorted at a time.

Note 5: With all outputs open, I<sub>CC</sub> is measured with the Q and Q̄ outputs high in turn. At the time of measurement the clock is grounded.

Note 6: Clear is tested with preset high and preset is tested with clear high.

T-46-07-08

74

**Switching Characteristics** at  $V_{CC} = 5V$  and  $T_A = 25^\circ C$  (See Section 1 for Test Waveforms and Output Load)

Symbol	Parameter	From (Input) To (Output)	$R_L = 400\Omega$ $C_L = 15\text{ pF}$		Units
			Min	Max	
$f_{MAX}$	Maximum Clock Frequency		15		MHz
$t_{PHL}$	Propagation Delay Time High to Low Level Output	Preset to $\bar{Q}$		40	ns
$t_{PLH}$	Propagation Delay Time Low to High Level Output	Preset to Q		25	ns
$t_{PHL}$	Propagation Delay Time High to Low Level Output	Clear to Q		40	ns
$t_{PLH}$	Propagation Delay Time Low to High Level Output	Clear to $\bar{Q}$		25	ns
$t_{PHL}$	Propagation Delay Time High to Low Level Output	Clock to Q or $\bar{Q}$		40	ns
$t_{PLH}$	Propagation Delay Time Low to High Level Output	Clock to Q or $\bar{Q}$		25	ns

4