



FAST CMOS OCTAL BUFFER/LINE DRIVER

IDT 54/74FCT240
IDT 54/74FCT240A

FEATURES:

- IDT54/74FCT240 equivalent to FAST™ speed;
IDT54/74FCT240A 30% faster than FAST™
- Equivalent to FAST™ output drive over full temperature and voltage supply extremes
- $I_{OL} = 64\text{mA}$ (commercial) and 48mA (military)
- CMOS power levels (5μW typ. static)
- TTL input and output level compatible
- CMOS output level compatible
- Substantially lower input current levels than FAST™ (5μA max.)
- Octal buffer/line driver with 3-state output
- JEDEC standard pinout for DIP and LCC
- Product available in Radiation Tolerant and Enhanced versions
- Military product compliant to MIL-STD-883, Class B
- Standard Military Drawing# 5962-87655 is listed on this function.

DESCRIPTION:

The IDT54/74FCT240/A are octal buffer/line drivers built using advanced CEMOS™, a dual metal CMOS technology. The devices are designed to be employed as memory and address drivers, clock drivers and bus-oriented transmitter/receivers which provide improved board density.

PIN CONFIGURATIONS

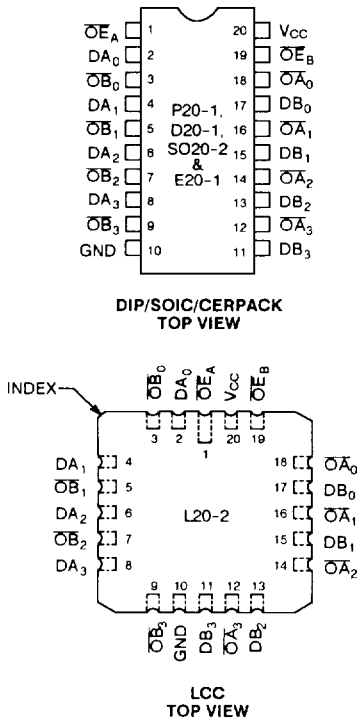

FUNCTIONAL BLOCK DIAGRAM

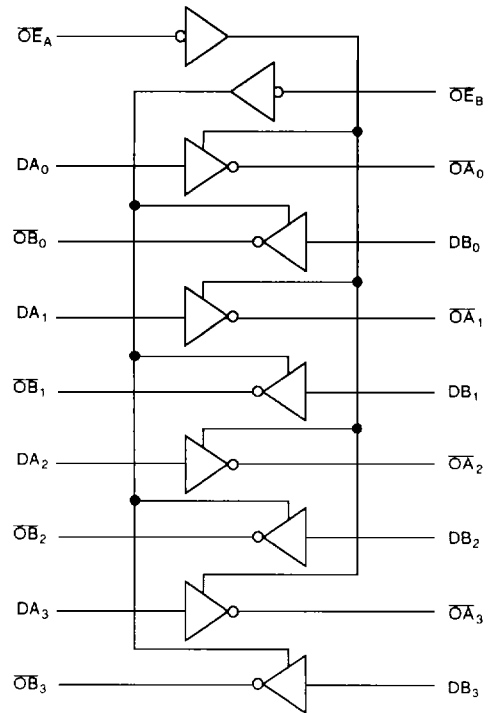

CEMOS is a trademark of Integrated Device Technology, Inc.
FAST is a trademark of Fairchild Semiconductor Co.

MILITARY AND COMMERCIAL TEMPERATURE RANGES

JANUARY 1989

ABSOLUTE MAXIMUM RATINGS⁽¹⁾

SYMBOL	RATING	COMMERCIAL	MILITARY	UNIT
V _{TERM}	Terminal Voltage with Respect to GND	-0.5 to +7.0	-0.5 to +7.0	V
T _A	Operating Temperature	0 to +70	-55 to +125	°C
T _{BIAS}	Temperature Under Bias	-55 to +125	-65 to +135	°C
T _{STG}	Storage Temperature	-55 to +125	-65 to +150	°C
P _T	Power Dissipation	0.5	0.5	W
I _{OUT}	DC Output Current	120	120	mA

NOTE:

1. Stresses greater than those listed under ABSOLUTE MAXIMUM RATINGS may cause permanent damage to the device. This is a stress rating only and functional operation of the device at these or any other conditions above those indicated in the operational sections of this specification is not implied. Exposure to absolute maximum rating conditions for extended periods may affect reliability.

CAPACITANCE (T_A = +25°C, f = 1.0MHz)

SYMBOL	PARAMETER ⁽¹⁾	CONDITIONS	TYP.	MAX.	UNIT
C _{IN}	Input Capacitance	V _{IN} = 0V	6	10	pF
C _{OUT}	Output Capacitance	V _{OUT} = 0V	8	12	pF

NOTES:

1. This parameter is measured at characterization but not tested.

DC ELECTRICAL CHARACTERISTICS OVER OPERATING RANGE

Following Conditions Apply Unless Otherwise Specified:

V_{LC} = 0.2V; V_{HIC} = V_{CC} - 0.2V

Commercial: T_A = 0°C to +70°C; V_{CC} = 5.0V ±5%

Military: T_A = -55°C to +125°C; V_{CC} = 5.0V ±10%

SYMBOL	PARAMETER	TEST CONDITIONS ⁽¹⁾	MIN.	TYP. ⁽²⁾	MAX.	UNIT	
V _{IH}	Input HIGH Level	Guaranteed Logic High Level	2.0	—	—	V	
V _{IL}	Input LOW Level	Guaranteed Logic Low Level	—	—	0.8	V	
I _{IH}	Input HIGH Current	V _{CC} = Max.	V _I = V _{CC}	—	—	5	μA
I _{IL}	Input LOW Current		V _I = 2.7V	—	—	5 ⁽⁴⁾	
			V _I = 0.5V	—	—	-5 ⁽⁴⁾	
			V _I = GND	—	—	-5	
I _{OZ}	Off State (High Impedance) Output Current	V _{CC} = Max.	V _O = V _{CC}	—	—	10	μA
			V _O = 2.7V	—	—	10 ⁽⁴⁾	
			V _O = 0.5V	—	—	-10 ⁽⁴⁾	
			V _O = GND	—	—	-10	
V _{IK}	Clamp Diode Voltage	V _{CC} = Min., I _N = -18mA	—	-0.7	-1.2	V	
I _{OS}	Short Circuit Current	V _{CC} = Max ⁽³⁾ , V _O = GND	-60	-120	—	mA	
V _{OH}	Output HIGH Voltage	V _{CC} = 3V, V _{IN} = V _{LC} or V _{HIC} , I _{OH} = -32μA	V _{HIC}	V _{CC}	—	V	
		V _{CC} = Min. V _{IN} = V _{IH} or V _{IL}	I _{OH} = -300μA	V _{HIC}	V _{CC}		—
			I _{OH} = -12mA MIL.	2.4	4.3		—
V _{OL}	Output LOW Voltage	V _{CC} = 3V, V _{IN} = V _{LC} or V _{HIC} , I _{OL} = 300μA	—	GND	V _{LC}	V	
		V _{CC} = Min. V _{IN} = V _{IH} or V _{IL}	I _{OL} = 300μA	—	GND		V _{LC}
			I _{OL} = 48mA MIL.	—	0.3		0.55
		I _{OL} = 64mA COM'L.	—	0.3	0.55		

NOTES:

- For conditions shown as max. or min., use appropriate value specified under Electrical Characteristics for the applicable device type
- Typical values are at V_{CC} = 5.0V, +25°C ambient and maximum loading.
- Not more than one output should be shorted at one time. Duration of the short circuit test should not exceed one second.
- This parameter is guaranteed but not tested.

10

POWER SUPPLY CHARACTERISTICS FOR 'FCT240

$V_{LC} = 0.2V$; $V_{HC} = V_{CC} - 0.2V$

SYMBOL	PARAMETER	TEST CONDITIONS ⁽¹⁾		MIN.	TYP. ⁽²⁾	MAX.	UNIT
I_{CC}	Quiescent Power Supply Current	$V_{CC} = \text{Max.}$ $V_{IN} \geq V_{HC}$; $V_{IN} \leq V_{LC}$ $f_i = 0$		—	0.001	1.5	mA
ΔI_{CC}	Quiescent Power Supply Current TTL Inputs HIGH	$V_{CC} = \text{Max.}$ $V_{IN} = 3.4V^{(3)}$		—	0.5	2.0	mA
I_{CCD}	Dynamic Power Supply Current ⁽⁴⁾	$V_{CC} = \text{Max.}$ Outputs Open $\overline{OE}_A = \overline{OE}_B = \text{GND}$ One Input Toggling 50% Duty Cycle	$V_{IN} \geq V_{HC}$ $V_{IN} \leq V_{LC}$	—	0.15	0.25	mA/ MHz
I_C	Total Power Supply Current ⁽⁶⁾	$V_{CC} = \text{Max.}$ Outputs Open $f_i = 10\text{MHz}$ 50% Duty Cycle $\overline{OE}_A = \overline{OE}_B = \text{GND}$ One Bit Toggling	$V_{IN} \geq V_{HC}$ $V_{IN} \leq V_{LC}$ (FCT)	—	1.5	4.0	mA
			$V_{IN} = 3.4V$ $V_{IN} = \text{GND}$	—	1.8	5.0	
		$V_{CC} = \text{Max.}$ Outputs Open $f_i = 2.5\text{MHz}$ 50% Duty Cycle $\overline{OE}_A = \overline{OE}_B = \text{GND}$ Eight Bits Toggling	$V_{IN} \geq V_{HC}^{(6)}$ $V_{IN} \leq V_{LC}$ (FCT)	—	3.0	6.5 ⁽⁵⁾	
			$V_{IN} = 3.4V^{(6)}$ $V_{IN} = \text{GND}$	—	5.0	14.5 ⁽⁵⁾	

NOTES:

- For conditions shown as max. or min., use appropriate value specified under Electrical Characteristics for the applicable device type.
- Typical values are at $V_{CC} = 5.0V$, $+25^\circ\text{C}$ ambient and maximum loading.
- Per TTL driven input ($V_{IN} = 3.4V$); all other inputs at V_{CC} or GND.
- This parameter is not directly testable, but is derived for use in Total Power Supply calculations.
- Values for these conditions are examples of the I_{CC} formula. These limits are guaranteed but not tested.
- $I_C = I_{\text{QUIESCENT}} + I_{\text{INPUTS}} + I_{\text{DYNAMIC}}$
 $I_C = I_{CC} + \Delta I_{CC} D_H N_T + I_{CCD} (f_{CP}/2 + f_i N_i)$
 I_{CC} = Quiescent Current
 ΔI_{CC} = Power Supply Current for a TTL High Input ($V_{IN} = 3.4V$)
 D_H = Duty Cycle for TTL Inputs High
 N_T = Number of TTL Inputs at D_H
 I_{CCD} = Dynamic Current Caused by an Input Transition Pair (HLH or LHL)
 f_{CP} = Clock Frequency for Register Devices (Zero for Non-Register Devices)
 f_i = Input Frequency
 N_i = Number of Inputs at f_i
 All currents are in milliamps and all frequencies are in megahertz.

DEFINITION OF FUNCTIONAL TERMS

PIN NAMES	DESCRIPTION
$\overline{OE}_A, \overline{OE}_B$	3-State Output Enable Input (Active LOW)
D_{xx}	Inputs
O_{xx}	Outputs

TRUTH TABLE

INPUTS		OUTPUT
$\overline{OE}_A, \overline{OE}_B$	D	
L	L	H
L	H	L
H	X	Z

H = HIGH Voltage Level
L = LOW Voltage Level
X = Don't Care
z = High Impedance

SWITCHING CHARACTERISTICS OVER OPERATING RANGE

SYMBOL	PARAMETER	CONDITION ⁽¹⁾	IDT54/74FCT240				IDT54/74FCT240A				UNIT		
			TYP. ⁽³⁾	COM'L.		MIL.		TYP. ⁽³⁾	COM'L.			MIL.	
				MIN. ⁽²⁾	MAX.	MIN. ⁽²⁾	MAX.		MIN. ⁽²⁾	MAX.			
t_{PLH} t_{PHL}	Propagation Delay D_n to O_n	$C_L = 50pF$ $R_L = 500\Omega$	5.0	1.5	8.0	1.5	9.0	3.5	1.5	4.8	1.5	5.1	ns
t_{PZH} t_{PZL}	Output Enable Time		7.0	1.5	10.0	1.5	10.5	4.8	1.5	6.2	1.5	6.5	ns
t_{PHZ} t_{PLZ}	Output Disable Time		6.0	1.5	9.5	1.5	12.5	4.3	1.5	5.6	1.5	5.9	ns

NOTES:

- See test circuit and waveforms.
- Minimum limits are guaranteed but not tested on Propagation Delays.
- Typical values are at $V_{CC} = 5.0V$, $+25^\circ C$ ambient and maximum loading.

ORDERING INFORMATION

10

