

REVISIONS			
LTR	DESCRIPTION	DATE (YR-MO-DA)	APPROVED
A	Add paragraph 1.3 and Appendix A in accordance with NOR 5962-R031-97.	96-11-06	R. MONNIN
B	Add device class T criteria. Editorial changes throughout. Redrawn. -lgt	98-12-23	R. MONNIN
C	Add vendor CAGE F8859. Updated footnote 2/ in table I to accommodate RHA designator "D". Update boilerplate to reflect current requirements. -rrp	02-11-27	R. MONNIN
D	Add junction temperature to 1.3. Made change to propagation delay time tests, t <sub>PZH</sub> /t <sub>PZL</sub> and t <sub>PLZ</sub> /t <sub>PHZ</sub> in table I. - rrp	07-03-02	J. RODENBECK
E	Make a correction to Figure 2 by replacing the second from the left ENABLE with ENABLE . - ro	08-03-20	R. HEBER
F	Add device type 02. Update radiation features under paragraph 1.5. Add paragraph 2.2 ASTM information and Table IB. Delete table III, Dose rate induced latchup testing and Dose rate upset testing paragraphs. - ro	12-04-17	C. SAFFLE
G	Add case outline Y. Add note under figure 1. Delete device class M references. - ro	13-05-22	C. SAFFLE
H	Make correction to footnote 5/ as specified under Table I by deleting 500 Ω and replace with 50 Ω. - ro	14-04-01	C. SAFFLE

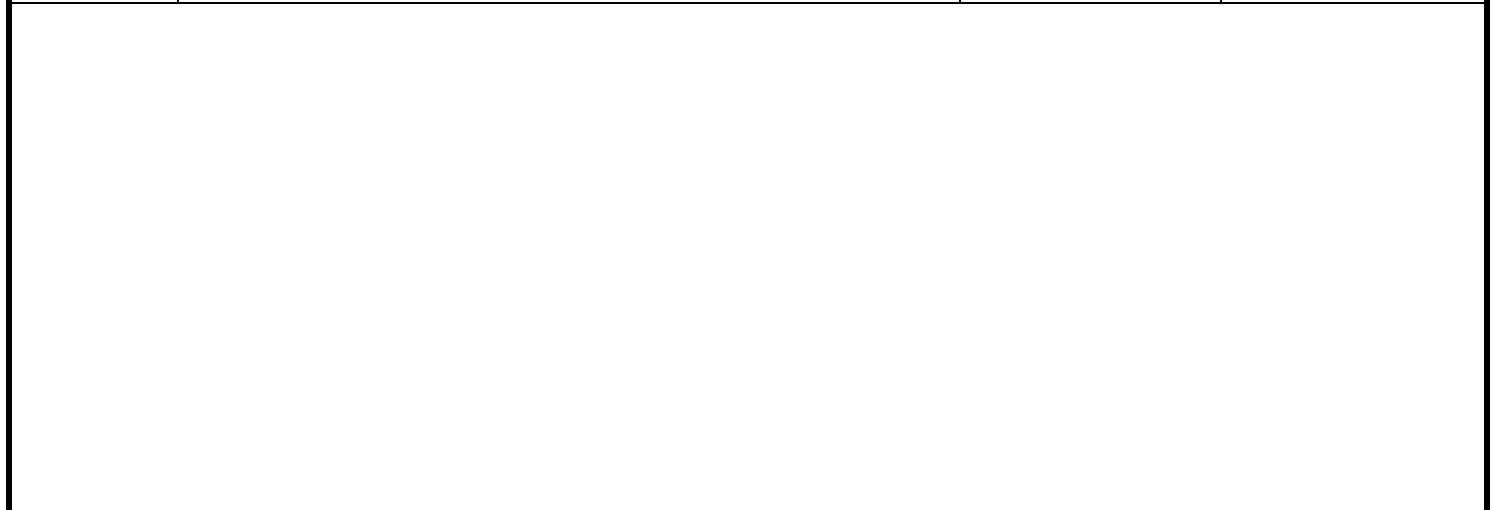

REV																				
SHEET																				
REV	H	H	H	H	H	H	H	H	H	H										
SHEET	15	16	17	18	19	20	21	22	23	24										
REV STATUS OF SHEETS	REV			SHEET			H	H	H	H	H	H	H	H	H	H	H	H	H	H
							1	2	3	4	5	6	7	8	9	10	11	12	13	14

PMIC N/A	PREPARED BY KENNETH S. RICE	<b>DLA LAND AND MARITIME</b> <b>COLUMBUS, OHIO 43218-3990</b> <a href="http://www.landandmaritime.dla.mil">http://www.landandmaritime.dla.mil</a>																			
<b>STANDARD MICROCIRCUIT DRAWING</b>  THIS DRAWING IS AVAILABLE FOR USE BY ALL DEPARTMENTS AND AGENCIES OF THE DEPARTMENT OF DEFENSE	CHECKED BY SANDRA ROONEY																				
	APPROVED BY MICHAEL FRYE																				
	DRAWING APPROVAL DATE 95-07-13																				
AMSC N/A	REVISION LEVEL H	SIZE A	CAGE CODE <b>67268</b>	<b>5962-95632</b>																	
		SHEET 1 OF 24																			

1. SCOPE

1.1 Scope. This drawing documents three product assurance class levels consisting of high reliability (device class Q), space application (device class V) and for appropriate satellite and similar applications (device class T). A choice of case outlines and lead finishes are available and are reflected in the Part or Identifying Number (PIN). When available, a choice of Radiation Hardness Assurance (RHA) levels is reflected in the PIN. For device class T, the user is encouraged to review the manufacturer's Quality Management (QM) plan as part of their evaluation of these parts and their acceptability in the intended application.

1.2 PIN. The PIN is as shown in the following example:

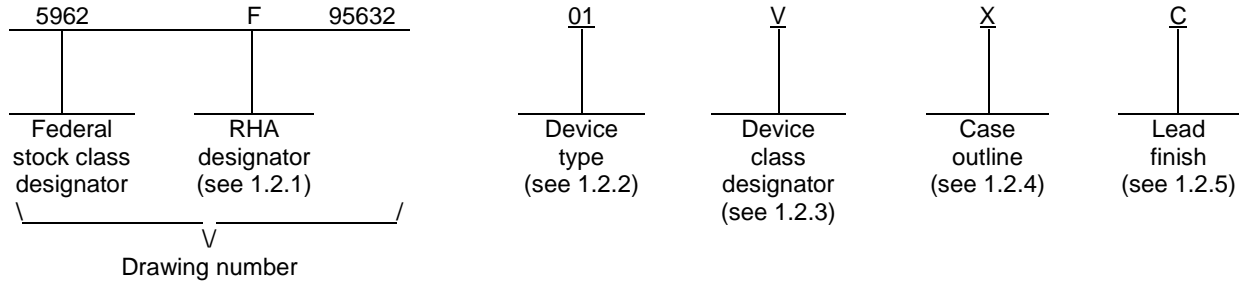

1.2.1 RHA designator. Device classes Q, T and V RHA marked devices meet the MIL-PRF-38535 specified RHA levels and are marked with the appropriate RHA designator. A dash (-) indicates a non-RHA device.

1.2.2 Device type(s). The device type(s) identify the circuit function as follows:

<u>Device type</u>	<u>Generic number</u>	<u>Circuit function</u>
01	26CT31RH	Radiation hardened quad differential line driver
02	26CT31EH	Radiation hardened quad differential line driver

1.2.3 Device class designator. The device class designator is a single letter identifying the product assurance level as follows:

<u>Device class</u>	<u>Device requirements documentation</u>
Q, V	Certification and qualification to MIL-PRF-38535
T	Certification and qualification to MIL-PRF-38535 with performance as specified in the device manufacturers approved quality management plan.

1.2.4 Case outline(s). The case outline(s) are as designated in MIL-STD-1835 and as follows:

<u>Outline letter</u>	<u>Descriptive designator</u>	<u>Terminals</u>	<u>Package style</u>
E	CDIP2-T16	16	Dual-in-line
X	CDFP4-F16	16	Flat pack
Y	CDFP4-F16	16	Flat pack with grounded lid

1.2.5 Lead finish. The lead finish is as specified in MIL-PRF-38535 for device classes Q, T and V.

<b>STANDARD MICROCIRCUIT DRAWING</b> DLA LAND AND MARITIME COLUMBUS, OHIO 43218-3990	SIZE <b>A</b>		<b>5962-95632</b>
		REVISION LEVEL H	SHEET 2

1.3 Absolute maximum ratings. 1/

Supply voltage .....	-0.5 V to +7.0 V
Inputs, E, $\bar{E}$ voltage .....	-0.5 V to $V_{DD}+0.5$ V
Output voltage (power on or off (0.0 V)) .....	-0.5 V to +7.0 V
DC diode input current (any input) .....	$\pm 20$ mA
DC drain current (any output) .....	350 mA
DC $V_{DD}$ or ground current .....	400 mA
Power dissipation at $T_A = 125^\circ\text{C}$ ( $P_D$ ) .....	0.44 W <u>2/</u>
For $T_A = -55^\circ\text{C}$ to $125^\circ\text{C}$ :	
Case outline E .....	0.667 W
Case outlines X and Y .....	0.526 W
Storage temperature range .....	$-65^\circ\text{C}$ to $+150^\circ\text{C}$
Lead temperature (soldering, 10 seconds) .....	$300^\circ\text{C}$
Junction temperature ( $T_J$ ) .....	$+175^\circ\text{C}$
Thermal resistance, junction-to-case ( $\theta_{JC}$ ) .....	See MIL-STD-1835
Thermal resistance, junction-to-ambient ( $\theta_{JA}$ ):	
Case outline E .....	$75^\circ\text{C/W}$
Case outlines X and Y .....	$95^\circ\text{C/W}$

1.4 Recommended operating conditions.

Operating temperature range ( $T_A$ ) .....	$-55^\circ\text{C}$ to $+125^\circ\text{C}$
Supply voltage range ( $V_{DD}$ ) .....	$+4.5$ V to $+5.5$ V
Low input voltage ( $V_{IL}$ ) .....	0 V to 0.8 V, maximum
High input voltage ( $V_{IH}$ ) .....	$V_{DD}$ to $V_{DD}/2$ V, minimum
Input rise and fall time .....	500 ns maximum
Dynamic current ( $I_{DYN}$ ) at $+25^\circ\text{C}$ .....	3 mA
Power dissipation capacitance ( $CP_D$ ) at $+25^\circ\text{C}$ .....	170 pF

1/ Stresses above the absolute maximum rating may cause permanent damage to the device. Extended operation at the maximum levels may degrade performance and affect reliability.

2/ Maximum device power dissipation is defined as  $V_{DD} \times I_{CC}$  and must withstand the added  $P_D$  due to output current test  $I_O$  at  $T_A = +125^\circ\text{C}$ .

<b>STANDARD MICROCIRCUIT DRAWING</b> DLA LAND AND MARITIME COLUMBUS, OHIO 43218-3990	SIZE <b>A</b>		<b>5962-95632</b>
		REVISION LEVEL H	SHEET 3

1.5 Radiation features.

Maximum total dose available (dose rate = 50 – 300 rads(Si)/s):	
Device type 01 classes Q or V .....	300 krad(Si) <u>3/</u>
Device type 01 class T .....	100 krad(Si) <u>3/</u>
Device type 02 .....	300 krad(Si) <u>4/</u>
Maximum total dose available (dose rate ≤ 0.01 rad(Si)/s):	
Device type 02.....	50 krad(Si) <u>4/</u>
Single event phenomena (SEP):	
No single event latch up (SEL) occurs at effective (LET) (see 4.4.3.) .....	≤ 100 MeV/mg/cm <sup>2</sup> <u>5/</u>

The manufacturer supplying RHA device types 01 and 02 on this drawing has performed characterization testing to demonstrate that the parts do not exhibit enhanced low dose rate sensitivity (ELDRS) in accordance with MIL-STD-883, method 1019, paragraph 3.13.1.1. Therefore these parts may be considered ELDRS free at a level of 100 krad(Si). The manufacturer will perform only high dose rate lot acceptance testing on a wafer by wafer basis in accordance with MIL-STD-883, method 1019, condition A for device type 01. The manufacturer will perform high dose rate and low dose rate lot acceptance testing on a wafer by wafer basis in accordance with MIL-STD-883, method 1019, conditions A and D for device type 02.

2. APPLICABLE DOCUMENTS

2.1 Government specification, standards, and handbooks. The following specification, standards, and handbooks form a part of this drawing to the extent specified herein. Unless otherwise specified, the issues of these documents are those cited in the solicitation or contract.

DEPARTMENT OF DEFENSE SPECIFICATION

MIL-PRF-38535 - Integrated Circuits, Manufacturing, General Specification for.

DEPARTMENT OF DEFENSE STANDARDS

MIL-STD-883 - Test Method Standard Microcircuits.  
MIL-STD-1835 - Interface Standard Electronic Component Case Outlines.

DEPARTMENT OF DEFENSE HANDBOOKS

MIL-HDBK-103 - List of Standard Microcircuit Drawings.  
MIL-HDBK-780 - Standard Microcircuit Drawings.

(Copies of these documents are available online at <http://quicksearch.dla.mil> or from the Standardization Document Order Desk, 700 Robbins Avenue, Building 4D, Philadelphia, PA 19111-5094.)

- 3/ The manufacturer supplying device type 01 has performed characterization testing in accordance with MIL-STD-883 method 1019 paragraph 3.13.1.1 and the parts exhibited no enhanced low dose rate sensitivity (ELDRS) at a level of 100 krad(Si). The radiation end point limits for the noted parameters are guaranteed only for the conditions as specified in MIL-STD-883, method 1019, condition A to a maximum total dose of 300 krad(Si) for device classes V, Q, or M and 100 krad(Si) for device class T.
- 4/ The manufacturer supplying device type 02 has performed characterization testing in accordance with MIL-STD-883 method 1019 paragraph 3.13.1.1 and the parts exhibited no enhanced low dose rate sensitivity (ELDRS) at a level of 100 krad(Si). The radiation end point limits for the noted parameters are guaranteed only for the conditions as specified in MIL-STD-883, method 1019, condition A to a maximum total dose of 300 krad(Si), and condition D to a maximum total dose of 50 krad(Si).
- 5/ Guaranteed by process or design, not tested.

<b>STANDARD  MICROCIRCUIT DRAWING</b> DLA LAND AND MARITIME COLUMBUS, OHIO 43218-3990	SIZE <b>A</b>		<b>5962-95632</b>
		REVISION LEVEL H	SHEET 4

2.2 Non-Government publications. The following document(s) form a part of this document to the extent specified herein. Unless otherwise specified, the issues of the documents are the issues of the documents cited in the solicitation or contract.

ASTM INTERNATIONAL (ASTM)

ASTM F1192 – Standard Guide for the Measurement of Single Event Phenomena (SEP) Induced by Heavy Ion Irradiation of Semiconductor Devices.

(Copies of this document is available online at <http://www.astm.org/> or from ASTM International, P.O. Box C700, 100 Bar Harbor Drive, West Conshohocken, PA 19428-2959).

2.3 Order of precedence. In the event of a conflict between the text of this drawing and the references cited herein, the text of this drawing takes precedence. Nothing in this document, however, supersedes applicable laws and regulations unless a specific exemption has been obtained.

3. REQUIREMENTS

3.1 Item requirements. The individual item requirements for device classes Q, T and V shall be in accordance with MIL-PRF-38535 as specified herein, or as modified in the device manufacturer's Quality Management (QM) plan. The modification in the QM plan shall not affect the form, fit, or function as described herein.

3.1.1 Microcircuit die. For the requirements of microcircuit die, see appendix A to this document.

3.2 Design, construction, and physical dimensions. The design, construction, and physical dimensions shall be as specified in MIL-PRF-38535 and herein for device classes Q, T and V.

3.2.1 Case outlines. The case outlines shall be in accordance with 1.2.4 herein.

3.2.2 Terminal connections. The terminal connections shall be as specified on figure 1.

3.2.3 Truth table. The truth table shall be as specified on figure 2.

3.2.4 Radiation exposure circuit. The radiation exposure circuit shall be maintained by the manufacturer under document revision level control and shall be made available to the preparing and acquiring activity upon request.

3.3 Electrical performance characteristics and postirradiation parameter limits. Unless otherwise specified herein, the electrical performance characteristics and postirradiation parameter limits are as specified in table IA and shall apply over the full ambient operating temperature range.

3.4 Electrical test requirements. The electrical test requirements shall be the subgroups specified in table IIA. The electrical tests for each subgroup are defined in table IA.

3.5 Marking. The part shall be marked with the PIN listed in 1.2 herein. In addition, the manufacturer's PIN may also be marked. For packages where marking of the entire SMD PIN number is not feasible due to space limitations, the manufacturer has the option of not marking the "5962-" on the device. For RHA product using this option, the RHA designator shall still be marked. Marking for device classes Q, T and V shall be in accordance with MIL-PRF-38535.

3.5.1 Certification/compliance mark. The certification mark for device classes Q, T and V shall be a "QML" or "Q" as required in MIL-PRF-38535.

3.6 Certificate of compliance. For device classes Q, T and V, a certificate of compliance shall be required from a QML-38535 listed manufacturer in order to supply to the requirements of this drawing (see 6.6.1 herein). The certificate of compliance submitted to DLA Land and Maritime -VA prior to listing as an approved source of supply for this drawing shall affirm that the manufacturer's product meets, for device classes Q, T and V, the requirements of MIL-PRF-38535 and herein.

3.7 Certificate of conformance. A certificate of conformance as required for device classes Q, T and V in MIL-PRF-38535 shall be provided with each lot of microcircuits delivered to this drawing.

<b>STANDARD MICROCIRCUIT DRAWING</b> DLA LAND AND MARITIME COLUMBUS, OHIO 43218-3990	SIZE <b>A</b>		<b>5962-95632</b>
		REVISION LEVEL H	SHEET 5

TABLE IA. Electrical performance characteristics.

Test	Symbol	Conditions <u>1/ 2/</u> -55°C ≤ T <sub>A</sub> ≤ +125°C unless otherwise specified	Group A subgroups	Device type	Limits		Unit
					Min	Max	
High level output voltage	V <sub>OH</sub>	V <sub>DD</sub> = 4.5 V and 5.5 V, I <sub>O</sub> = -20 mA <u>3/ 4/</u>	1, 2, 3	01, 02	2.5		V
Low level output voltage	V <sub>OL</sub>	V <sub>DD</sub> = 4.5 V and 5.5 V, I <sub>O</sub> = 20 mA <u>3/ 4/</u>	1, 2, 3	01, 02		0.5	V
Differential output voltage	V <sub>T</sub> , $\overline{V_T}$	V <sub>DD</sub> = V <sub>IH</sub> = 4.5 V, V <sub>IL</sub> = 0 V, R <sub>L</sub> = R1 + R2 <u>5/</u>	1, 2, 3	01, 02	2.0		V
Difference in differential output	$ V_T  -  \overline{V_T} $	V <sub>DD</sub> = V <sub>IH</sub> = 4.5 V, V <sub>IL</sub> = 0 V, R <sub>L</sub> = R1 + R2 <u>5/</u>	1, 2, 3	01, 02		0.4	V
Common Mode Output voltage	$ V_{OS} - \overline{V_{OS}} $	V <sub>DD</sub> = V <sub>IH</sub> = 4.5 V, V <sub>IL</sub> = 0 V, R <sub>L</sub> = R1 + R2 <u>5/</u>	1, 2, 3	01, 02		3.0	V
Difference in Common Mode Output	$ V_{OS} - \overline{V_{OS}} $	V <sub>DD</sub> = V <sub>IH</sub> = 4.5 V, V <sub>IL</sub> = 0 V, R <sub>L</sub> = R1 + R2 <u>5/</u>	1, 2, 3	01, 02		0.4	V
High level input voltage	V <sub>IH</sub>	V <sub>DD</sub> = 4.5 V, 5.5 V <u>6/</u>	1, 2, 3	01, 02	V <sub>DD</sub> /2.0		V
Low level input voltage	V <sub>IL</sub>	V <sub>DD</sub> = 4.5 V, 5.5 V <u>6/</u>	1, 2, 3	01, 02		0.8	V
Standby supply current	I <sub>DDSB</sub>	V <sub>DD</sub> = 5.5 V, output = open, V <sub>IN</sub> = V <sub>DD</sub> or GND	1, 2, 3	01, 02		500	μA
Three-state output leakage current	I <sub>OZ</sub>	V <sub>DD</sub> = 5.5 V, force voltages = 0 V or V <sub>DD</sub> <u>7/</u>	1, 2, 3	01, 02		±5.0	μA
Delta supply current	ΔI <sub>CC</sub>	V <sub>DD</sub> = 5.5 V, V <sub>IN</sub> = 2.4 V, 0.5 V	1, 2, 3	01, 02		2.0	mA
Input leakage current	I <sub>IN</sub>	V <sub>DD</sub> = 5.5 V, V <sub>IN</sub> = V <sub>DD</sub> or GND	1, 2, 3	01, 02		±1.0	μA
Output leakage current power off	I <sub>OFF</sub>	V <sub>DD</sub> = 0.0 V, V <sub>OUT</sub> = 6.0 V, 250 mV, Inputs = GND	1, 2, 3	01, 02	-100	100	μA
Input clamp voltage	V <sub>IC</sub>	at -1.0 mA	1, 2, 3	01, 02		-1.5	V
		at +1.0 mA				+1.5	
Functional test		See 4.4.1b	7, 8A, 8B	01, 02			

See footnotes at end of table.

**STANDARD  
MICROCIRCUIT DRAWING**  
DLA LAND AND MARITIME  
COLUMBUS, OHIO 43218-3990

SIZE  
**A**

REVISION LEVEL  
**H**

**5962-95632**

SHEET  
**6**

TABLE IA. Electrical performance characteristics - Continued.

Test	Symbol	Conditions <u>1/ 2/</u> -55°C ≤ T <sub>A</sub> ≤ +125°C unless otherwise specified	Group A subgroups	Device type	Limits		Unit
					Min	Max	
Propagation delay time	T <sub>PLH</sub> , T <sub>PHL</sub>	V <sub>DD</sub> = 4.5 V <u>5/</u>	9, 10, 11	01, 02	2	22	ns
	T <sub>PZH</sub> , T <sub>PZL</sub>		9, 11		5	28	
			10		5	33	
	T <sub>PLZ</sub> , T <sub>PHZ</sub>		9, 11		2	22	
			10		2	27	
Rise and Fall time	T <sub>THL</sub> , T <sub>TLH</sub>	V <sub>DD</sub> = 4.5 V <u>5/</u>	9, 10, 11	01, 02	1	10	ns
Output skew	T <sub>SKEW</sub> <u>8/</u>	V <sub>DD</sub> = 4.5 V <u>5/</u> R <sub>L</sub> = 100 Ω, C <sub>L</sub> = 40 pF	9, 10, 11	01, 02		3	ns

Note : The below parameters are not part of the post irradiation electrical performance characteristics. 9/

Input capacitance	C <sub>IN</sub>	V <sub>DD</sub> = open, f = 1 MHz	4	01, 02		12	pF
Output capacitance	C <sub>OUT</sub>	V <sub>DD</sub> = open, f = 1 MHz	4	01, 02		12	pF
Operating short circuit	I <sub>OS</sub>	V <sub>DD</sub> = 5.5 V, V <sub>IN</sub> = V <sub>DD</sub> or GND, V <sub>OUT</sub> = 0 V <u>10/</u>	1, 2, 3	01, 02	-30	-150	mA
On-state resistance	R <sub>ON</sub>	V <sub>DD</sub> = 4.5 V, V <sub>OUT</sub> = 1.5 V, V <sub>IN</sub> = V <sub>DD</sub> or GND	1, 2, 3	01, 02		10	Ω

1/ RHA device type 01 supplied to this drawing meet all levels M, D, P, L, R and F of irradiation for device classes Q or V and levels M, D, P, L, and R for device class T. However, device type 01 for device classes Q and V are only tested at the "F" level, and device class T is only tested at the "R" level (see 1.5 herein) in accordance with MIL-STD-883 method 1019 condition A.

RHA device type 02 supplied to this drawing will meet all levels M, D, P, L, R, and F of irradiation for condition A and levels M, D, P, and L for condition D. However, device type 02 is only tested at the "F" level in accordance with MIL-STD-883, method 1019, condition A, and tested at the "L" level in accordance with MIL-STD-883, method 1019, condition D (see 1.5 herein).

Pre and post irradiation values are identical unless otherwise specified in Table IA. When performing post irradiation electricals measurements for any RHA level, T<sub>A</sub> = +25°C.

2/ All voltages referenced to device ground.

3/ Force/measure functions may be interchanged.

4/ V<sub>IL</sub> = 0.8 V and V<sub>IN</sub> = V<sub>DD</sub>/2.

**STANDARD  
MICROCIRCUIT DRAWING**  
DLA LAND AND MARITIME  
COLUMBUS, OHIO 43218-3990

SIZE  
**A**

REVISION LEVEL  
H

**5962-95632**

SHEET  
7

TABLE IA. Electrical performance characteristics - Continued.

- 5/ These conditions are detailed in EIA specification RS-422, (R1 = R2 = 50 Ω). See figure 3 as applicable.
- 6/ This parameter tested as inputs for the V<sub>OL</sub>, V<sub>OH</sub>, and I<sub>OZ</sub>, and function tests.
- 7/ The inputs are conditioned to have the output in the opposite state of the forcing I<sub>OZ</sub> condition.
- 8/ Skew is defined as the difference in propagation delays between complementary outputs at the 50% point.
- 9/ Tested initially and after any design or process changes that affect these parameters, and therefore shall meet the values listed in table IA.
- 10/ Only one output at a time shall be shorted.

TABLE IB. SEP test limits. 1/ 2/

Device types	Bias for Single event latch-up (SEL) test; maximum operating voltage V <sub>DD</sub> = 5.5 V No SEL at effective LET = [MeV/mg/cm <sup>2</sup> ] 3/ 4/ 5/
01, 02	LET ≤ 100

- 1/ For SEP test conditions, see 4.4.4.3 herein.
- 2/ Technology characterization and model verification supplemented by in-line data may be used in lieu of end-of-line testing. Test plan must be approved by TRB and qualifying activity.
- 3/ Tested for latch-up at worst case operating temperature, T<sub>A</sub> = +125°C ± 10°C.
- 4/ Tested to LET ≤ 100 MeV/mg/cm<sup>2</sup> and no latch-up occurs.
- 5/ Guaranteed by process or design, not tested.

<b>STANDARD MICROCIRCUIT DRAWING</b> DLA LAND AND MARITIME COLUMBUS, OHIO 43218-3990	SIZE <b>A</b>		<b>5962-95632</b>
		REVISION LEVEL <b>H</b>	SHEET <b>8</b>



Device types	01 and 02
Case outlines	E, X and Y SEE NOTE
Terminal number	Terminal symbol
1	A <sub>IN</sub>
2	A <sub>O</sub>
3	$\overline{A\text{O}}$
4	ENABLE
5	$\overline{B\text{O}}$
6	B <sub>O</sub>
7	B <sub>IN</sub>
8	GND
9	C <sub>IN</sub>
10	C <sub>O</sub>
11	$\overline{C\text{O}}$
12	$\overline{\text{ENABLE}}$
13	$\overline{D\text{O}}$
14	D <sub>O</sub>
15	D <sub>IN</sub>
16	V <sub>DD</sub>

Note: For case outline Y only, the lid is grounded.

FIGURE 1. Terminal connections.

<b>STANDARD MICROCIRCUIT DRAWING</b> DLA LAND AND MARITIME COLUMBUS, OHIO 43218-3990	SIZE <b>A</b>		<b>5962-95632</b>
		REVISION LEVEL H	SHEET 9

Device Power ON/OFF	INPUTS			OUTPUT	
	ENABLE	$\overline{\text{ENABLE}}$	IN	OUT	$\overline{\text{OUT}}$
ON	0	1	X	HI-Z	HI-Z
ON	1	X	0	0	1
ON	X	0	0	0	1
ON	1	X	1	1	0
ON	X	0	1	1	0
OFF (0 V)	X	X	X	HI-Z	HI-Z

FIGURE 2. Truth table.

<b>STANDARD MICROCIRCUIT DRAWING</b> DLA LAND AND MARITIME COLUMBUS, OHIO 43218-3990	SIZE <b>A</b>		<b>5962-95632</b>
		REVISION LEVEL H	SHEET 10

Propagation delay timing diagram

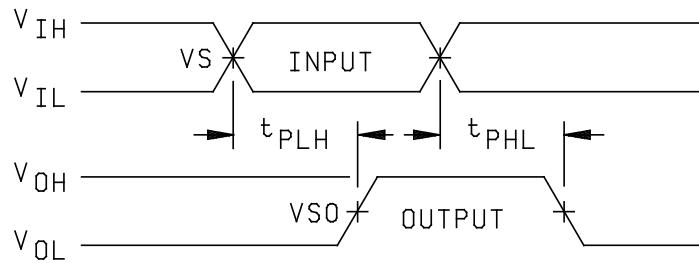

Note : Voltage levels  
 $V_{DD} = 4.50 \text{ V}$   
 $V_{IH} = 3.00 \text{ V}$   
 $V_S = 1.30 \text{ V}$   
 $V_{IL} = 0.0 \text{ V}$   
 $GND = 0.0 \text{ V}$   
 $V_{SO} = 50\%$

Propagation delay load circuit

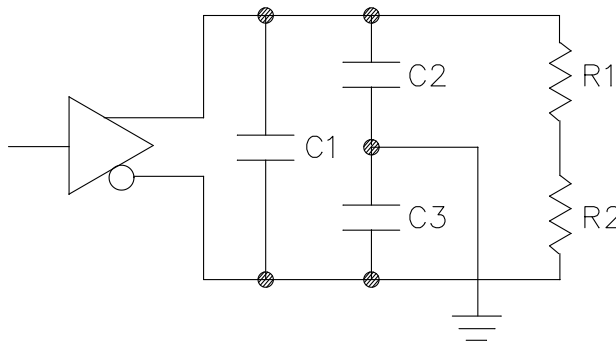

$C_1 = C_2 = C_3 = 40 \text{ pF}$   
 $R_1 = R_2 = 50 \Omega$

FIGURE 3. Timing and load circuit diagrams.

**STANDARD  
MICROCIRCUIT DRAWING**  
DLA LAND AND MARITIME  
COLUMBUS, OHIO 43218-3990

SIZE  
**A**

REVISION LEVEL  
**H**

**5962-95632**

SHEET  
**11**

Three-state low timing diagram

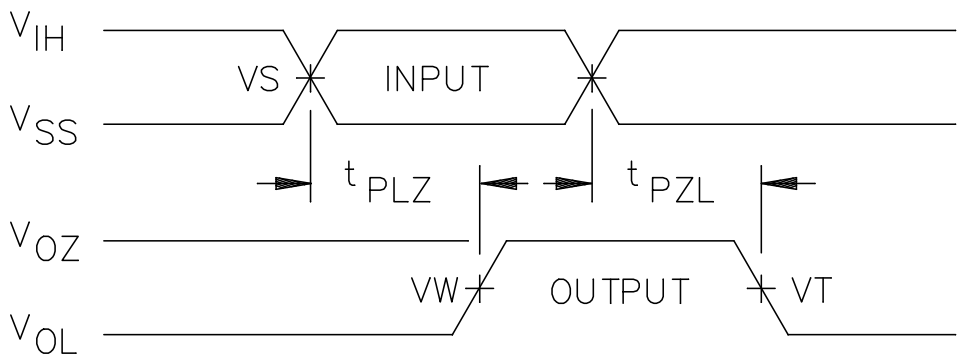

Note : Voltage levels  
 $V_{DD} = 4.50 \text{ V}$   
 $V_{IH} = 3.00 \text{ V}$   
 $V_S = 1.30 \text{ V}$   
 $V_W = V_{OL} + 0.3 \text{ V}$   
 $V_T = 0.60 \text{ V}$

Three-state low load circuit

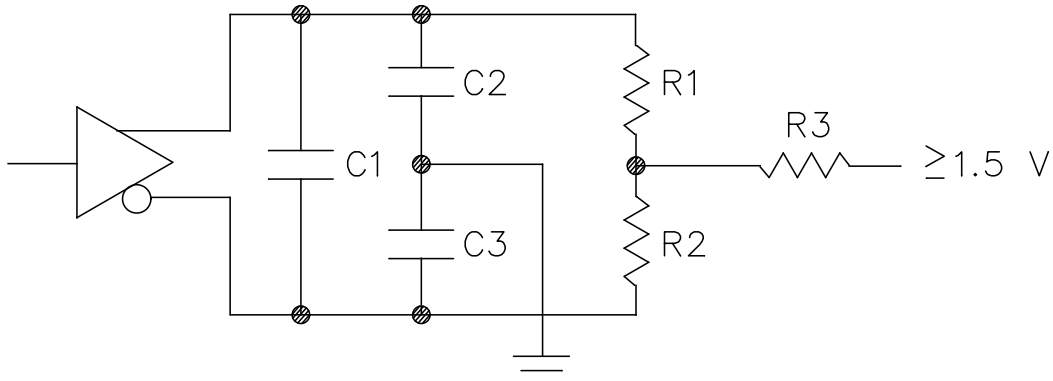

$C1 = C2 = C3 = 40 \text{ pF}$   
 $R1 = R2 = 50 \Omega$   
 $R3 = 500 \Omega$

FIGURE 3. Timing and load circuit diagrams – Continued.

<b>STANDARD                  MICROCIRCUIT DRAWING</b> DLA LAND AND MARITIME COLUMBUS, OHIO 43218-3990	SIZE <b>A</b>		<b>5962-95632</b>
		REVISION LEVEL H	SHEET 12

Three-state high timing diagram

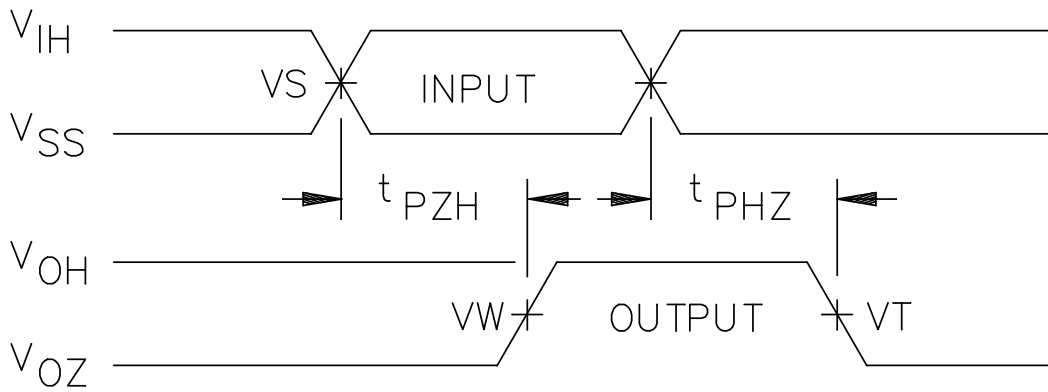

Note : Voltage levels  
 $V_{DD} = 4.50 \text{ V}$   
 $V_{IH} = 3.00 \text{ V}$   
 $V_S = 1.30 \text{ V}$   
 $V_T = V_{OH} - 0.3 \text{ V}$   
 $V_W = 2.00 \text{ V}$

Three-state high load circuit

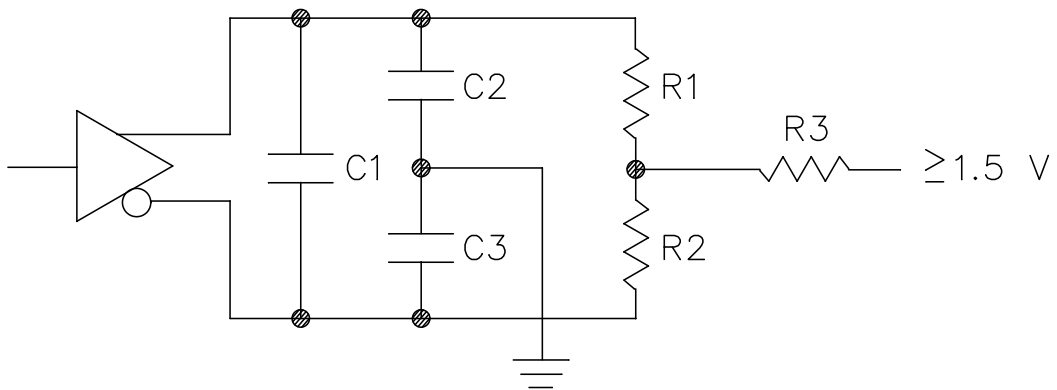

$C1 = C2 = C3 = 40 \text{ pF}$   
 $R1 = R2 = 50 \Omega$   
 $R3 = 500 \Omega$

FIGURE 3. Timing and load circuit diagrams – Continued.

**STANDARD  
MICROCIRCUIT DRAWING**  
DLA LAND AND MARITIME  
COLUMBUS, OHIO 43218-3990

SIZE  
**A**

REVISION LEVEL  
**H**

**5962-95632**

SHEET  
**13**

4. VERIFICATION

4.1 Sampling and inspection. For device classes Q, and V, sampling and inspection procedures shall be in accordance with MIL-PRF-38535 or as modified in the device manufacturer's Quality Management (QM) plan, including screening (4.2), qualification (4.3), and conformance inspection (4.4). The modification in the QM plan shall not affect the form, fit, or function as described herein. For device class T, sampling and inspection procedures shall be in accordance with MIL-PRF-38535 and the device manufacturer's QM plan including screening, qualification, and conformance inspection. The performance envelope and reliability information shall be as specified in the manufacturer's QM plan.

4.2 Screening. For device classes Q and V, screening shall be in accordance with MIL-PRF-38535, and shall be conducted on all devices prior to qualification and technology conformance inspection. For device class T, screening shall be in accordance with the device manufacturer's Quality Management (QM) plan, and shall be conducted on all devices prior to qualification and technology conformance inspection.

4.2.1 Additional criteria for device classes Q, T and V.

- a. The burn-in test duration, test condition and test temperature, or approved alternatives shall be as specified in the device manufacturer's QM plan in accordance with MIL-PRF-38535. The burn-in test circuit shall be maintained under document revision level control of the device manufacturer's Technology Review Board (TRB) in accordance with MIL-PRF-38535 and shall be made available to the acquiring or preparing activity upon request. The test circuit shall specify the inputs, outputs, biases, and power dissipation, as applicable, in accordance with the intent specified in method 1015 of MIL-STD-883.
- b. For device classes Q, T and V interim and final electrical test parameters shall be as specified in table IIA herein.
- c. Additional screening for device class V beyond the requirements of device class Q shall be as specified in MIL-PRF-38535, Appendix B.

4.3 Qualification inspection for device classes Q, T and V. Qualification inspection for device classes Q and V shall be in accordance with MIL-PRF-38535. Qualification inspection for device class T shall be in accordance with the device manufacturer's Quality Management (QM) plan. Inspections to be performed shall be those specified in MIL-PRF-38535 and herein for groups A, B, C, D, and E inspections (see 4.4.1 through 4.4.4).

4.4 Conformance inspection. Technology conformance inspection for classes Q and V shall be in accordance with MIL-PRF-38535 including groups A, B, C, D, and E inspections, and as specified herein. Technology conformance inspection for class T shall be in accordance with the device manufacturer's Quality Management (QM) plan.

4.4.1 Group A inspection.

- a. Tests shall be as specified in table IIA herein.
- b. For device classes Q and V, subgroups 7 and 8 shall include verifying the functionality of the device.
- c. Subgroups 5 and 6 in table I, method 5005 of MIL-STD-883 shall be omitted.
- d. Subgroup 4 (C<sub>IN</sub> and C<sub>OUT</sub> measurement) shall be measured only for the initial test and after process or design changes which may affect input capacitances.

4.4.2 Group C inspection. The group C inspection end-point electrical parameters shall be as specified in table IIA herein.

4.4.2.1 Additional criteria for device classes Q, T and V. The steady-state life test duration, test condition and test temperature, or approved alternatives shall be as specified in the device manufacturer's QM plan in accordance with MIL-PRF-38535. The test circuit shall be maintained under document revision level control by the device manufacturer's TRB in accordance with MIL-PRF-38535 and shall be made available to the acquiring or preparing activity upon request. The test circuit shall specify the inputs, outputs, biases, and power dissipation, as applicable, in accordance with the intent specified in method 1005 of MIL-STD-883.

4.4.3 Group D inspection. The group D inspection end-point electrical parameters shall be as specified in table IIA herein.

<b>STANDARD MICROCIRCUIT DRAWING</b> DLA LAND AND MARITIME COLUMBUS, OHIO 43218-3990	SIZE <b>A</b>		<b>5962-95632</b>
		REVISION LEVEL H	SHEET 14

TABLE IIA. Electrical test requirements.

Test requirements	Subgroups (in accordance with MIL-PRF-38535, table III)		
	Device class Q	Device class V	Device class T
Interim electrical parameters (see 4.2)	1,7,9	1,7,9	As specified in QM plan
Final electrical parameters (see 4.2)	1,2,3,7,8A, <u>1/</u> 8B,9,10,11	1,2,3,7, <u>1/ 2/</u> 8A,8B 9,10,11	As specified in QM plan
Group A test requirements (see 4.4)	1,2,3,4,7, <u>3/</u> 8A,8B,9,10,11	1,2,3,4,7, <u>3/</u> 8A,8B,9,10,11	As specified in QM plan
Group C end-point electrical parameters (see 4.4)	1,2,3,7,8A,8B,9, 10,11	1,2,3,7, <u>2/</u> 8A,8B,9,10,11	As specified in QM plan
Group D end-point electrical parameters (see 4.4)	1,7,9	1,7,9	As specified in QM plan
Group E end-point electrical parameters (see 4.4)	1,7,9	1,7,9	As specified in QM plan

- 1/ PDA applies to subgroups 1, 7, and 9. For class V to subgroups 1, 7, 9, and Δ.  
2/ Delta limits (see table IIB) shall be required and the delta values shall be computed with reference to the zero hour electrical parameters (see table IA).  
3/ Subgroup 4, if not tested, shall be guaranteed to the limits specified in table IA.

TABLE IIB. Burn-in and operating life test delta parameters. (T<sub>A</sub> = +25°C)

Test <u>1/</u>	Symbol	Device types	Delta limits
High level output voltage	V <sub>OH</sub>	01, 02	±150 mV
Low level output voltage	V <sub>OL</sub>	01, 02	±60 mV
Standby supply current	I <sub>DDSB</sub>	01, 02	±100 μA
Three state output leakage current	I <sub>OZ</sub>	01, 02	±1.0 μA
Input leakage current	I <sub>IN</sub>	01, 02	±150 nA

- 1/ The above parameters shall be recorded before and after the required burn-in and life test to determine the delta.

<b>STANDARD MICROCIRCUIT DRAWING</b> DLA LAND AND MARITIME COLUMBUS, OHIO 43218-3990	SIZE <b>A</b>		<b>5962-95632</b>
		REVISION LEVEL H	SHEET 15

4.4.4 Group E inspection. Group E inspection is required only for parts intended to be marked as radiation hardness assured (see 3.5 herein). RHA levels for device classes Q and V shall be as specified in MIL-PRF-38535. End-point electrical parameters shall be as specified in table IIA herein.

4.4.4.1 Group E inspection for device class T. For device class T, the RHA requirements shall be in accordance with the class T radiation requirements of MIL-PRF-38535. End-point electrical parameters shall be as specified in table IIA herein.

4.4.4.2 Total dose irradiation testing. Total dose irradiation testing high dose rate shall be performed in accordance with MIL-STD-883 method 1019, condition A and as specified herein for device types 01 and 02. Total dose irradiation testing at low dose rate shall be performed in accordance with MIL-STD-883 method 1019, condition D and as specified herein for device type 02.

4.4.4.2.1 Accelerated annealing test. Accelerated annealing tests shall be performed on all devices requiring a RHA level greater than 5 krads(Si). The post-anneal end-point electrical parameter limits shall be as specified in table IA herein and shall be the pre-irradiation end-point electrical parameter limit at 25°C ±5°C. Testing shall be performed at initial qualification and after any design or process changes which may affect the RHA response of the device.

4.4.4.3 Single event phenomena (SEP). When specified in the purchase order or contract, SEP testing shall be performed on class V devices. SEP testing shall be performed on the Standard Evaluation Circuit (SEC) or alternate SEP test vehicle as approved by the qualifying activity at initial qualification and after any design or process changes which may affect the upset or latchup characteristics. Test four devices with zero failures. ASTM F1192 may be used as a guideline when performing SEP testing. The recommended test conditions for SEP are as follows:

- a. The ion beam angle of incidence shall be between normal to the die surface and 60° to the normal, inclusive (i.e.  $0^\circ \leq \text{angle} \leq 60^\circ$ ). No shadowing of the ion beam due to fixturing or package related effects is allowed.
- b. The fluence shall be  $\geq 100$  errors or  $\geq 10^7$  ions/cm<sup>2</sup>.
- c. The flux shall be between  $10^2$  and  $10^5$  ions/cm<sup>2</sup>/s. The cross-section shall be verified to be flux independent by measuring the cross-section at two flux rates which differ by at least an order of magnitude.
- d. The particle range shall be  $\geq 20$  microns in silicon.
- e. The test temperature shall be +25°C and the maximum rated operating temperature  $\pm 10^\circ\text{C}$ .
- f. Bias conditions shall be defined by the manufacturer for latchup measurements.
- g. Test four devices with zero failures.

5. PACKAGING

5.1 Packaging requirements. The requirements for packaging shall be in accordance with MIL-PRF-38535 for device classes Q, T and V.

<b>STANDARD MICROCIRCUIT DRAWING</b> DLA LAND AND MARITIME COLUMBUS, OHIO 43218-3990	SIZE <b>A</b>		<b>5962-95632</b>
		REVISION LEVEL H	SHEET 16



6. NOTES

6.1 Intended use. Microcircuits conforming to this drawing are intended for use for Government microcircuit applications (original equipment), design applications, and logistics purposes.

6.1.1 Replaceability. Microcircuits covered by this drawing will replace the same generic device covered by a contractor prepared specification or drawing.

6.2 Configuration control of SMD's. All proposed changes to existing SMD's will be coordinated with the users of record for the individual documents. This coordination will be accomplished using DD Form 1692, Engineering Change Proposal.

6.3 Record of users. Military and industrial users should inform DLA Land and Maritime when a system application requires configuration control and which SMD's are applicable to that system. DLA Land and Maritime will maintain a record of users and this list will be used for coordination and distribution of changes to the drawings. Users of drawings covering microelectronic devices (FSC 5962) should contact DLA Land and Maritime-VA, telephone (614) 692-8108.

6.4 Comments. Comments on this drawing should be directed to DLA Land and Maritime-VA, Columbus, Ohio 43218-3990, or telephone (614) 692-0540.

6.5 Abbreviations, symbols, and definitions. The abbreviations, symbols, and definitions used herein are defined in MIL-PRF-38535 and MIL-HDBK-1331.

6.6 Sources of supply.

6.6.1 Sources of supply for device classes Q, T and V. Sources of supply for device classes Q, T and V are listed in MIL-HDBK-103 and QML-38535. The vendors listed in MIL-HDBK-103 and QML-38535 have submitted a certificate of compliance (see 3.6 herein) to DLA Land and Maritime-VA and have agreed to this drawing.

6.7 Additional information. When applicable a copy of the following additional data shall be maintained and available from the device manufacturer:

- a. RHA upset levels.
- b. Test conditions (SEP).
- c. Occurrence of latchup (SEL).

<b>STANDARD MICROCIRCUIT DRAWING</b> DLA LAND AND MARITIME COLUMBUS, OHIO 43218-3990	SIZE <b>A</b>		<b>5962-95632</b>
		REVISION LEVEL <b>H</b>	SHEET <b>17</b>

APPENDIX A  
APPENDIX A FORMS A PART OF SMD 5962-95632

A.1 SCOPE

A.1.1 Scope. This appendix establishes minimum requirements for microcircuit die to be supplied under the Qualified Manufacturers List (QML) Program. QML microcircuit die meeting the requirements of MIL-PRF-38535 and the manufacturers approved QM plan for use in monolithic microcircuits, multi-chip modules (MCMs), hybrids, electronic modules, or devices using chip and wire designs in accordance with MIL-PRF-38534 are specified herein. Two product assurance classes consisting of military high reliability (device class Q) and space application (device class V) are reflected in the Part or Identification Number (PIN). When available, a choice of Radiation Hardiness Assurance (RHA) levels are reflected in the PIN.

A.1.2 PIN. The PIN is as shown in the following example:

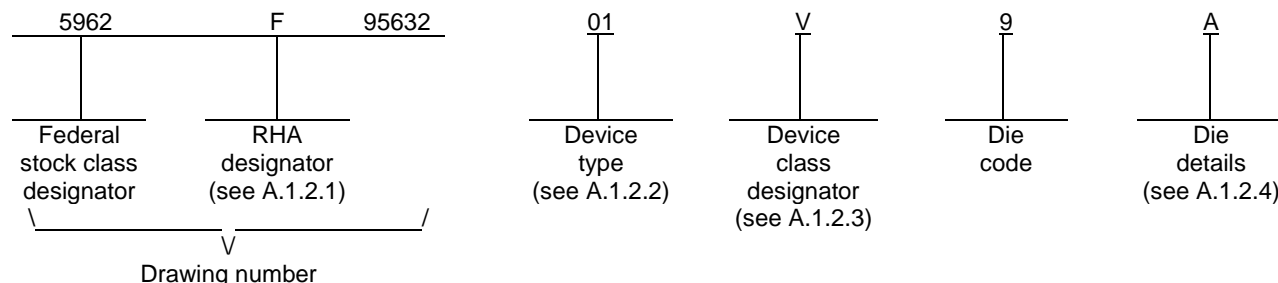

A.1.2.1 RHA designator. Device classes Q and V RHA identified die meet the MIL-PRF-38535 specified RHA levels. A dash (-) indicates a non-RHA die.

A.1.2.2 Device type(s). The device type(s) identify the circuit function as follows:

<u>Device type</u>	<u>Generic number</u>	<u>Circuit function</u>
01	26CT31RH	Radiation hardened quad differential line driver
02	26CT31EH	Radiation hardened quad differential line driver

A.1.2.3 Device class designator.

<u>Device class</u>	<u>Device requirements documentation</u>
Q or V	Certification and qualification to the die requirements of MIL-PRF-38535

<b>STANDARD MICROCIRCUIT DRAWING</b> DLA LAND AND MARITIME COLUMBUS, OHIO 43218-3990	SIZE <b>A</b>		<b>5962-95632</b>
		REVISION LEVEL H	SHEET 18

APPENDIX A  
APPENDIX A FORMS A PART OF SMD 5962-95632

A.1.2.4 Die details. The die details designation is a unique letter which designates the die's physical dimensions, bonding pad location(s) and related electrical function(s), interface materials, and other assembly related information, for each product and variant supplied to this appendix.

A.1.2.4.1 Die physical dimensions.

<u>Die type</u>	<u>Figure number</u>
01, 02	A-1

A.1.2.4.2 Die bonding pad locations and electrical functions.

<u>Die type</u>	<u>Figure number</u>
01, 02	A-1

A.1.2.4.3 Interface materials.

<u>Die type</u>	<u>Figure number</u>
01, 02	A-1

A.1.2.4.4 Assembly related information.

<u>Die type</u>	<u>Figure number</u>
01, 02	A-1

A.1.3 Absolute maximum ratings. See paragraph 1.3 herein for details.

A.1.4 Recommended operating conditions. See paragraph 1.4 herein for details.

A.1.5 Radiation features. See paragraph 1.5 herein for details.

<b>STANDARD MICROCIRCUIT DRAWING</b> DLA LAND AND MARITIME COLUMBUS, OHIO 43218-3990	SIZE <b>A</b>		<b>5962-95632</b>
		REVISION LEVEL H	SHEET 19

APPENDIX A  
APPENDIX A FORMS A PART OF SMD 5962-95632

A.2 APPLICABLE DOCUMENTS.

A.2.1 Government specification, standards, and handbooks. The following specification, standards, and handbooks form a part of this drawing to the extent specified herein. Unless otherwise specified, the issues of these documents are those cited in the solicitation or contract.

DEPARTMENT OF DEFENSE SPECIFICATION

MIL-PRF-38535 - Integrated Circuits, Manufacturing, General Specification for.

DEPARTMENT OF DEFENSE STANDARD

MIL-STD-883 - Test Method Standard Microcircuits.

DEPARTMENT OF DEFENSE HANDBOOKS

MIL-HDBK-103 - List of Standard Microcircuit Drawings.

MIL-HDBK-780 - Standard Microcircuit Drawings.

(Copies of these documents are available online at <http://quicksearch.dla.mil> or from the Standardization Document Order Desk, 700 Robbins Avenue, Building 4D, Philadelphia, PA 19111-5094.)

A.2.2 Order of precedence. In the event of a conflict between the text of this drawing and the references cited herein, the text of this drawing takes precedence. Nothing in this document, however, supersedes applicable laws and regulations unless a specific exemption has been obtained.

A.3 REQUIREMENTS

A.3.1 Item requirements. The individual item requirements for device classes Q and V shall be in accordance with MIL-PRF-38535 and as specified herein or as modified in the device manufacturer's Quality Management (QM) plan. The modification in the QM plan shall not affect the form, fit, or function as described herein.

A.3.2 Design, construction and physical dimensions. The design, construction, and physical dimensions shall be as specified in MIL-PRF-38535 and herein and the manufacturer's QM plan for device classes Q and V.

A.3.2.1 Die physical dimensions. The die physical dimensions shall be as specified in A.1.2.4.1 and on figure A-1.

A.3.2.2 Die bonding pad locations and electrical functions. The die bonding pad locations and electrical functions shall be as specified in A.1.2.4.2 and on figure A-1.

A.3.2.3 Interface materials. The interface materials for the die shall be as specified in A.1.2.4.3 and on figure A-1.

A.3.2.4 Assembly related information. The assembly related information shall be as specified in A.1.2.4.4 and on figure A-1.

A.3.2.5 Truth table. The truth table shall be as defined in figure 2.

A.3.2.6 Radiation exposure circuit. The radiation exposure circuit shall be as defined in 3.2.4.

<b>STANDARD MICROCIRCUIT DRAWING</b> DLA LAND AND MARITIME COLUMBUS, OHIO 43218-3990	SIZE <b>A</b>		<b>5962-95632</b>
		REVISION LEVEL H	SHEET 20

APPENDIX A  
APPENDIX A FORMS A PART OF SMD 5962-95632

A.3.3 Electrical performance characteristics and post-irradiation parameter limits. Unless otherwise specified herein, the electrical performance characteristics and post-irradiation parameter limits are as specified in table IA of the body of this document.

A.3.4 Electrical test requirements. The wafer probe test requirements shall include functional and parametric testing sufficient to make the packaged die capable of meeting the electrical performance requirements in table IA.

A.3.5 Marking. As a minimum, each unique lot of die, loaded in single or multiple stack of carriers, for shipment to a customer, shall be identified with the wafer lot number, the certification mark, the manufacturer's identification and the PIN listed in A.1.2 herein. The certification mark shall be a "QML" or "Q" as required by MIL-PRF-38535.

A.3.6 Certification of compliance. For device classes Q and V, a certificate of compliance shall be required from a QML-38535 listed manufacturer in order to supply to the requirements of this drawing (see A.6.4 herein). The certificate of compliance submitted to DLA Land and Maritime -VA prior to listing as an approved source of supply for this appendix shall affirm that the manufacturer's product meets, for device classes Q and V, the requirements of MIL-PRF-38535 and the requirements herein.

A.3.7 Certificate of conformance. A certificate of conformance as required for device classes Q and V in MIL-PRF-38535 shall be provided with each lot of microcircuit die delivered to this drawing.

A.4 VERIFICATION

A.4.1 Sampling and inspection. For device classes Q and V, die sampling and inspection procedures shall be in accordance with MIL-PRF-38535 or as modified in the device manufacturer's Quality Management (QM) plan. The modifications in the QM plan shall not affect the form, fit, or function as described herein.

A.4.2 Screening. For device classes Q and V, screening shall be in accordance with MIL-PRF-38535, and as defined in the manufacturer's QM plan. As a minimum, it shall consist of:

- a. Wafer lot acceptance for class V product using the criteria defined in MIL-STD-883, method 5007.
- b. 100% wafer probe (see paragraph A.3.4 herein).
- c. 100% internal visual inspection to the applicable class Q or V criteria defined in MIL-STD-883, method 2010 or the alternate procedures allowed in MIL-STD-883, method 5004.

A.4.3 Conformance inspection.

A.4.3.1 Group E inspection. Group E inspection is required only for parts intended to be identified as radiation assured (see A.3.5 herein). RHA levels for device classes Q and V shall be as specified in MIL-PRF-38535. End point electrical testing of packaged die shall be as specified in table IIA herein. Group E tests and conditions are as specified in paragraphs 4.4.4, 4.4.4.1, 4.4.4.2, 4.4.4.2.1, and 4.4.4.3 herein.

A.5 DIE CARRIER

A.5.1 Die carrier requirements. The requirements for the die carrier shall be accordance with the manufacturer's QM plan or as specified in the purchase order by the acquiring activity. The die carrier shall provide adequate physical, mechanical and electrostatic protection.

<b>STANDARD MICROCIRCUIT DRAWING</b> DLA LAND AND MARITIME COLUMBUS, OHIO 43218-3990	SIZE <b>A</b>		<b>5962-95632</b>
		REVISION LEVEL <b>H</b>	SHEET 21

APPENDIX A  
APPENDIX A FORMS A PART OF SMD 5962-95632

A.6 NOTES

A.6.1 Intended use. Microcircuit die conforming to this drawing are intended for use in microcircuits built in accordance with MIL-PRF-38535 or MIL-PRF-38534 for government microcircuit applications (original equipment), design applications, and logistics purposes.

A.6.2 Comments. Comments on this appendix should be directed to DLA Land and Maritime -VA, Columbus, Ohio, 43218-3990 or telephone (614)-692-0540.

A.6.3 Abbreviations, symbols, and definitions. The abbreviations, symbols, and definitions used herein are defined in MIL-PRF-38535 and MIL-HDBK-1331.

A.6.4 Sources of supply for device classes Q and V. Sources of supply for device classes Q and V are listed in QML-38535. The vendors listed within QML-38535 have submitted a certificate of compliance (see A.3.6 herein) to DLA Land and Maritime -VA and have agreed to this drawing.

<b>STANDARD MICROCIRCUIT DRAWING</b> DLA LAND AND MARITIME COLUMBUS, OHIO 43218-3990	SIZE <b>A</b>		<b>5962-95632</b>
		REVISION LEVEL <b>H</b>	SHEET 22

APPENDIX A  
 APPENDIX A FORMS A PART OF SMD 5962-95632

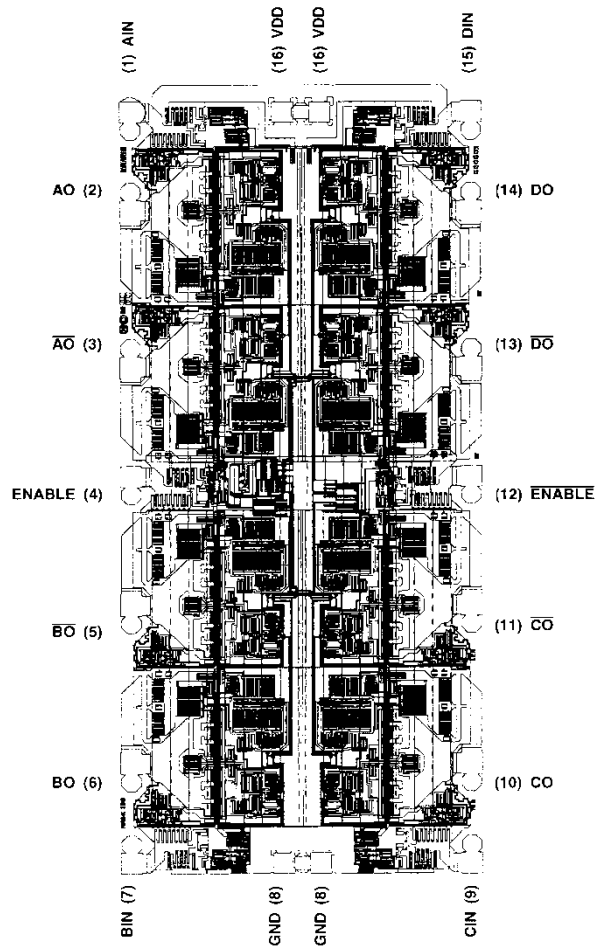

NOTE: Pad numbers reflect terminal numbers when placed in case outlines E, X, and Y (see figure 1).

FIGURE A-1. Die bonding pad locations and electrical functions.

<b>STANDARD          MICROCIRCUIT DRAWING</b> DLA LAND AND MARITIME COLUMBUS, OHIO 43218-3990	SIZE <b>A</b>		<b>5962-95632</b>
		REVISION LEVEL H	SHEET 23

APPENDIX A  
APPENDIX A FORMS A PART OF SMD 5962-95632

Die bonding pad locations and electrical functions

Die physical dimensions.

Die size: 2450 x 4950 microns

Die thickness:  $21 \pm 1$  mils

Interface materials.

Top metallization: Si Al Cu  $10.0 \text{ k\AA} \pm 2 \text{ k\AA}$

Backside metallization: None: chemical etch

Glassivation.

Type: PSG

Thickness:  $8 \text{ k\AA} \pm 1 \text{ k\AA}$

Substrate: Single crystal silicon

Assembly related information.

Substrate potential: Substrate internally tied to  $V_{DD}$

Special assembly instructions: None

FIGURE A-1. Die bonding pad locations and electrical functions - Continued.

<b>STANDARD MICROCIRCUIT DRAWING</b> DLA LAND AND MARITIME COLUMBUS, OHIO 43218-3990	SIZE <b>A</b>		<b>5962-95632</b>
		REVISION LEVEL H	SHEET 24



STANDARD MICROCIRCUIT DRAWING BULLETIN

DATE: 14-04-01

Approved sources of supply for SMD 5962-95632 are listed below for immediate acquisition information only and shall be added to MIL-HDBK-103 and QML-38535 during the next revision. MIL-HDBK-103 and QML-38535 will be revised to include the addition or deletion of sources. The vendors listed below have agreed to this drawing and a certificate of compliance has been submitted to and accepted by DLA Land and Maritime -VA. This information bulletin is superseded by the next dated revision of MIL-HDBK-103 and QML-38535. DLA Land and Maritime maintains an online database of all current sources of supply at <http://www.landandmaritime.dla.mil/Programs/Smcr/>.

Standard microcircuit drawing PIN <u>1</u> /	Vendor CAGE number	Vendor similar PIN <u>2</u> /
5962D9563201QXA	<u>3</u> /	26T31K02Q
5962D9563201VXA	<u>3</u> /	26T31K02V
5962D9563201QXC	<u>3</u> /	26T31K01Q
5962D9563201VXC	<u>3</u> /	26T31K01V
5962D9563201QEA	<u>3</u> /	26T31D09Q
5962D9563201VEA	<u>3</u> /	26T31D09V
5962D9563201QEC	<u>3</u> /	26T31D08Q
5962D9563201VEC	<u>3</u> /	26T31D08V
5962F9563201QEC	34371	HS1-26CT31RH-8
5962F9563201QXC	34371	HS9-26CT31RH-8
5962F9563201VEC	34371	HS1-26CT31RH-Q
5962F9563201VXC	34371	HS9-26CT31RH-Q
5962F9563201VYC	34371	HS9G-26CT31RH-Q
5962R9563201TEC	34371	HS1-26CT31RH-T
5962R9563201TXC	34371	HS9-26CT31RH-T
5962F9563201V9A	34371	HS0-26CT31RH-Q

STANDARD MICROCIRCUIT DRAWING BULLETIN – CONTINUED.

DATE: 14-04-01

Standard microcircuit drawing PIN <u>1/</u>	Vendor CAGE number	Vendor similar PIN <u>2/</u>
5962F9563202VEC	34371	HS1-26CT31EH-Q
5962F9563202VXC	34371	HS9-26CT31EH-Q
5962F9563202V9A	34371	HS0-26CT31EH-Q

- 1/ The lead finish shown for each PIN representing a hermetic package is the most readily available from the manufacturer listed for that part. If the desired lead finish is not listed contact the vendor to determine its availability.
- 2/ Caution. Do not use this number for item acquisition. Items acquired to this number may not satisfy the performance requirements of this drawing.
- 3/ Not available from an approved source of supply.

Vendor CAGE  
number

34371

Vendor name  
and address

Intersil Corporation  
1001 Murphy Ranch Road  
Milpitas, CA 95035-6803

The information contained herein is disseminated for convenience only and the Government assumes no liability whatsoever for any inaccuracies in the information bulletin.