

TRIPLE 3-INPUT NOR GATE

FEATURES

- Output capability: standard
- I_{CC} category: SSI

GENERAL DESCRIPTION

The 74HC/HCT27 are high-speed Si-gate CMOS devices and are pin compatible with low power Schottky TTL (LSTTL). They are specified in compliance with JEDEC standard no. 7A.

The 74HC/HCT27 provide the 3-input NOR function.

SYMBOL	PARAMETER	CONDITIONS	TYPICAL		UNIT
			HC	HCT	
t _{PHL} / t _{PLH}	propagation delay nA, nB, nC to nY	C _L = 15 pF V _{CC} = 5 V	8	10	ns
C _I	input capacitance		3.5	3.5	pF
CPD	power dissipation capacitance per gate	notes 1 and 2	24	30	pF

GND = 0 V; T_{amb} = 25 °C; t_r = t_f = 6 ns

Notes

1. CPD is used to determine the dynamic power dissipation (P_D in μW):

$$P_D = CPD \times V_{CC}^2 \times f_i + \sum (C_L \times V_{CC}^2 \times f_o) \text{ where:}$$

f_i = input frequency in MHz C_L = output load capacitance in pF
 f_o = output frequency in MHz V_{CC} = supply voltage in V
 Σ (C_L × V_{CC}² × f_o) = sum of outputs

2. For HC the condition is V_I = GND to V_{CC}
 For HCT the condition is V_I = GND to V_{CC} - 1.5 V

PACKAGE OUTLINES

14-lead DIL; plastic (SOT27).
 14-lead mini-pack; plastic (SO14; SOT108A).

PIN DESCRIPTION

PIN NO.	SYMBOL	NAME AND FUNCTION
1, 3, 9	1A to 3A	data inputs
2, 4, 10	1B to 3B	data inputs
13, 5, 11	1C to 3C	data inputs
7	GND	ground (0 V)
12, 6, 8	1Y to 3Y	data outputs
14	V _{CC}	positive supply voltage

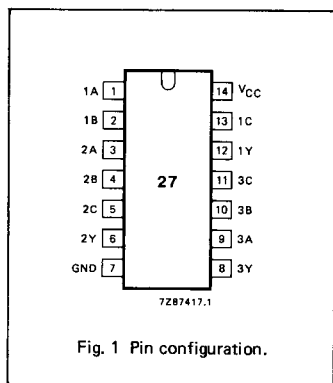

Fig. 1 Pin configuration.

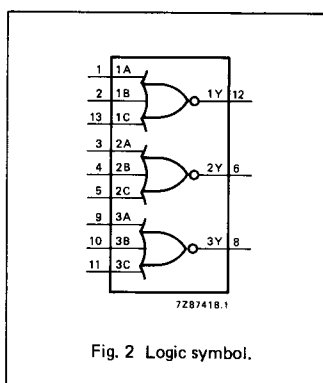

Fig. 2 Logic symbol.

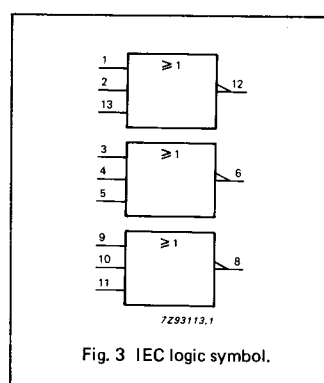

Fig. 3 IEC logic symbol.

74HC/HCT27
SSI

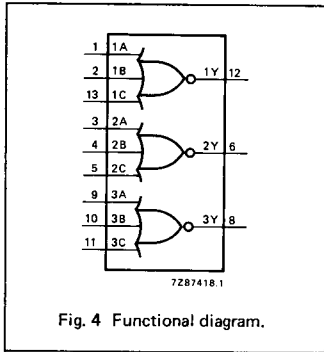

Fig. 4 Functional diagram.

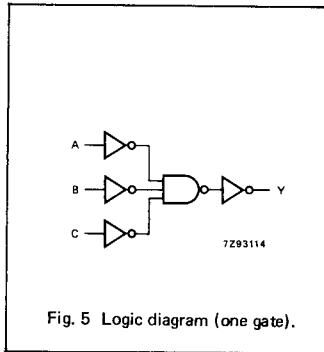

Fig. 5 Logic diagram (one gate).

FUNCTION TABLE

INPUTS			OUTPUT
nA	nB	nC	nY
L	L	L	H
X	X	H	L
X	H	X	L
H	X	X	L

H = HIGH voltage level
L = LOW voltage level
X = don't care

DC CHARACTERISTICS FOR 74HC

For the DC characteristics see chapter "HCMOS family characteristics", section "Family specifications".

Output capability: standard
I_{CC} category: SSI

AC CHARACTERISTICS FOR 74HC

GND = 0 V; t_r = t_f = 6 ns; C_L = 50 pF

SYMBOL	PARAMETER	T _{amb} (°C)						UNIT	TEST CONDITIONS		
		74HC							V _{CC} V	WAVEFORMS	
		+25			-40 to +85		-40 to +125				
		min.	typ.	max.	min.	max.	min.				max.
t _{PHL} / t _{PLH}	propagation delay nA, nB, nC to nY		28 10 8	90 18 15		115 23 20		135 27 23	ns	2.0 4.5 6.0	Fig. 6
t _{THL} / t _{TLH}	output transition time		19 7 6	75 15 13		95 19 16		110 22 19	ns	2.0 4.5 6.0	Fig. 6

DC CHARACTERISTICS FOR 74HCT

For the DC characteristics see chapter "HCMOS family characteristics", section "Family specifications".

Output capability: standard

I_{CC} category: SSI

Note to HCT types

The value of additional quiescent supply current (ΔI_{CC}) for a unit load of 1 is given in the family specifications. To determine ΔI_{CC} per input, multiply this value by the unit load coefficient shown in the table below.

INPUT	UNIT LOAD COEFFICIENT
nA, nB, nC	1.50

AC CHARACTERISTICS FOR 74HCT

GND = 0 V; $t_r = t_f = 6$ ns; $C_L = 50$ pF

SYMBOL	PARAMETER	T_{amb} (°C)						UNIT	TEST CONDITIONS		
		74HCT							V_{CC} V	WAVEFORMS	
		+25			-40 to +85		-40 to +125				
		min.	typ.	max.	min.	max.	min.				max.
t_{PHL}/t_{PLH}	propagation delay nA, nB, nC to nY		12	21		26		32	ns	4.5	Fig. 6
t_{THL}/t_{TLH}	output transition time		7	15		19		22	ns	4.5	Fig. 6

AC WAVEFORMS

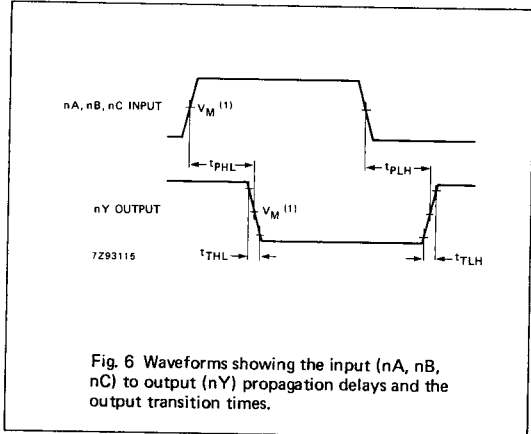

Fig. 6 Waveforms showing the input (nA, nB, nC) to output (nY) propagation delays and the output transition times.

Note to AC waveforms

- (1) HC : $V_M = 50\%$; $V_I = \text{GND to } V_{CC}$.
- HCT: $V_M = 1.3 \text{ V}$; $V_I = \text{GND to } 3 \text{ V}$.