

Low-Voltage CMOS 16-Bit Latching Transceiver

With 5V-Tolerant Inputs and Outputs (3-State, Non-Inverting)

The MC74LCX16543A is a high performance, non-inverting 16-bit latching transceiver operating from a 2.7 to 3.6V supply. The device is byte controlled. Each byte has separate control inputs which can be tied together for full 16-bit operation. High impedance TTL compatible inputs significantly reduce current loading to input drivers while TTL compatible outputs offer improved switching noise performance. A V_I specification of 5.5V allows MC74LCX16543A inputs to be safely driven from 5V devices. The MC74LCX16543A is suitable for memory address driving and all TTL level bus oriented transceiver applications.

For data flow from A to B with the EAB LOW, the A-to-B Output Enable (OEAB) must be LOW in order to enable data to the B bus, as indicated in the Function Table. With EAB LOW, a LOW signal on the A-to-B Latch Enable (LEAB) input makes the A-to-B latches transparent; a subsequent LOW-to-HIGH transition of the LEAB signal will latch the A latches, and the outputs no longer change with the A inputs. With EAB and OEAB both LOW, the 3-State B output buffers are active and reflect the data present at the output of the A latches. Control of data flow from B to A is symmetric to that above, but uses the EBA, LEBA, and OEBA inputs.

- Designed for 2.7 to 3.6V V_{CC} Operation
- 5.2ns Maximum t_{pd}
- 5V Tolerant — Interface Capability With 5V TTL Logic
- Supports Live Insertion and Withdrawal
- I_{OFF} Specification Guarantees High Impedance When $V_{CC} = 0V$
- LVTTTL Compatible
- LVCMOS Compatible
- 24mA Balanced Output Sink and Source Capability
- Near Zero Static Supply Current in All Three Logic States (20 μ A) Substantially Reduces System Power Requirements
- Latchup Performance Exceeds 500mA
- ESD Performance: Human Body Model >2000V; Machine Model >200V

MC74LCX16543A

LCX

**LOW-VOLTAGE CMOS
16-BIT LATCHING
TRANSCIEVER**



DT SUFFIX
56-LEAD PLASTIC TSSOP PACKAGE
CASE 1202-01

PIN NAMES

Pins	Function
\overline{OExxn}	Output Enable Inputs
\overline{Exxn}	Enable Inputs
\overline{LExn}	Latch Enable Inputs
A0-A15	3-State Inputs/Outputs
B0-B15	3-State Inputs/Outputs



LOGIC DIAGRAM

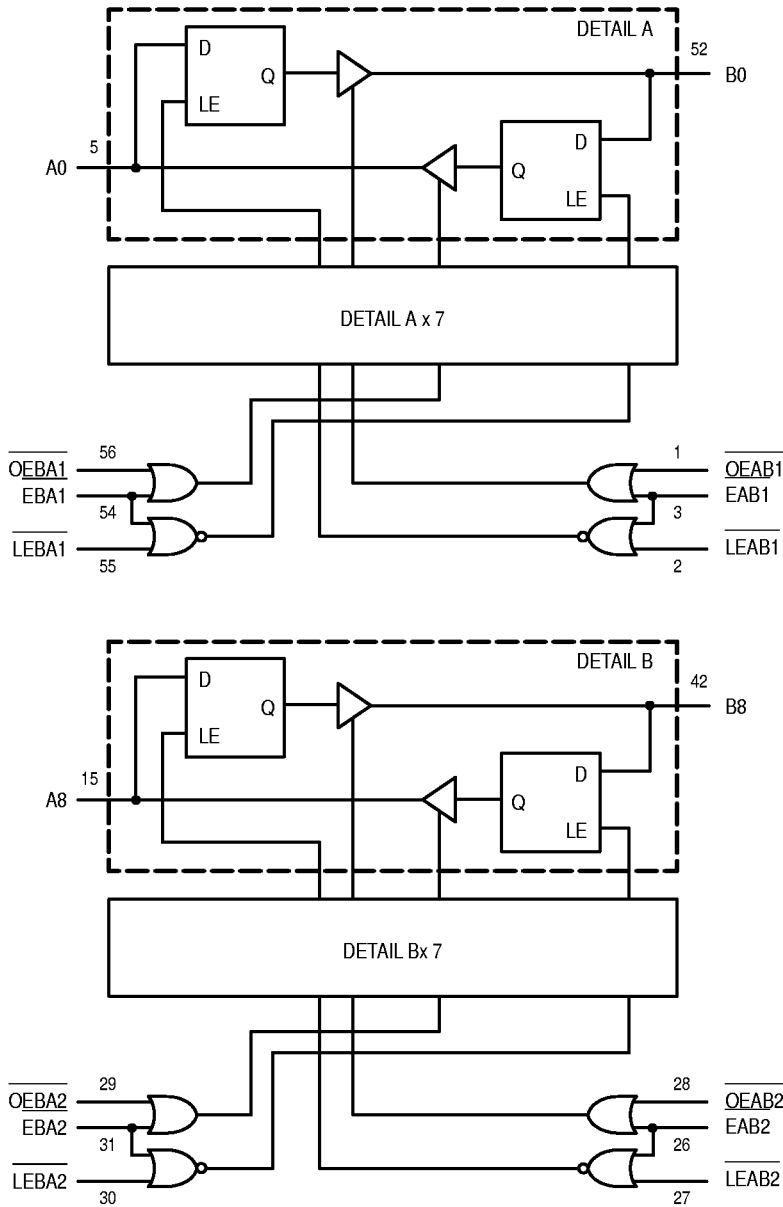

Pinout: 56-Lead TSSOP
(Top View)

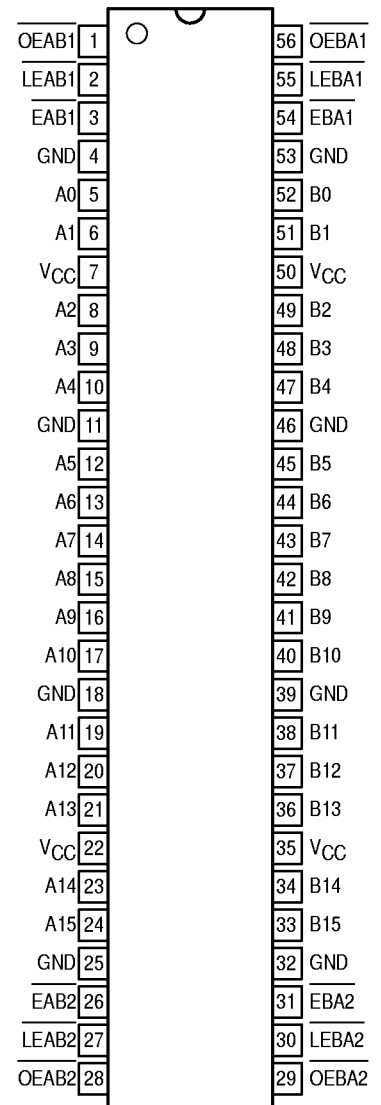

FUNCTION TABLE

Inputs						Data Ports		Operating Mode	
OEABn	OEBAn	EABn	EBAAn	LEABn	LEBAAn	An	Bn		
H	H					Input	Input		
		X	X	X	X	X	X	Disable Outputs	
		L	L	L	L	L	L	X	X
H	H			l	h	l	h	Latch and Outputs Disabled	
L	H					Input	Output		
		H	X*	L	X	l	Z	Z	Load and B Outputs Disabled
				H	X	X	X	Z	Hold; B Outputs Disabled
		L	X*	L	X	L	L	L	L
H	X			l	h	L	H	Latch and Display B Outputs	
H	L					Output	Input		
		X*	H	X	L	Z	l	h	Load and A Outputs Disabled
				X	H	Z	X	X	Hold; A Outputs Disabled
		X*	L	X	L	L	L	L	H
X	H			L	h	l	h	Latch and Display A Outputs	

H = High Voltage Level; h = High Voltage Level One Setup Time Prior to the Latch Enable or Enable Low-to-High Transition; L = Low Voltage Level; l = Low Voltage Level One Setup Time Prior to the Latch Enable or Enable Low-to-High Transition; X = Don't Care; * = The latches are not internally gated with the Output Enables. Therefore, data at the A or B ports may enter the latches at any time, provided that the LExx and Exx pins are set accordingly. For I_{CC} reasons, Do Not Float Inputs.

ABSOLUTE MAXIMUM RATINGS*

Symbol	Parameter	Value	Condition	Unit
V _{CC}	DC Supply Voltage	-0.5 to +7.0		V
V _I	DC Input Voltage	-0.5 ≤ V _I ≤ +7.0		V
V _O	DC Output Voltage	-0.5 ≤ V _O ≤ +7.0	Output in 3-State	V
		-0.5 ≤ V _O ≤ V _{CC} + 0.5	Note 1.	V
I _{IK}	DC Input Diode Current	-50	V _I < GND	mA
I _{OK}	DC Output Diode Current	-50	V _O < GND	mA
		+50	V _O > V _{CC}	mA
I _O	DC Output Source/Sink Current	±50		mA
I _{CC}	DC Supply Current Per Supply Pin	±100		mA
I _{GND}	DC Ground Current Per Ground Pin	±100		mA
T _{STG}	Storage Temperature Range	-65 to +150		°C

* Absolute maximum continuous ratings are those values beyond which damage to the device may occur. Exposure to these conditions or conditions beyond those indicated may adversely affect device reliability. Functional operation under absolute-maximum-rated conditions is not implied.

1. Output in HIGH or LOW State. I_O absolute maximum rating must be observed.

RECOMMENDED OPERATING CONDITIONS

Symbol	Parameter	Min	Typ	Max	Unit
V _{CC}	Supply Voltage	Operating	3.3	3.6	V
		Data Retention Only	1.5	3.6	
V _I	Input Voltage	0		5.5	V
V _O	Output Voltage (HIGH or LOW State) (3-State)	0 0		V _{CC} 5.5	V
I _{OH}	HIGH Level Output Current, V _{CC} = 3.0V – 3.6V			–24	mA
I _{OL}	LOW Level Output Current, V _{CC} = 3.0V – 3.6V			24	mA
I _{OH}	HIGH Level Output Current, V _{CC} = 2.7V – 3.0V			–12	mA
I _{OL}	LOW Level Output Current, V _{CC} = 2.7V – 3.0V			12	mA
T _A	Operating Free–Air Temperature	–40		+85	°C
Δt/ΔV	Input Transition Rise or Fall Rate, V _{IN} from 0.8V to 2.0V, V _{CC} = 3.0V	0		10	ns/V

DC ELECTRICAL CHARACTERISTICS

Symbol	Characteristic	Condition	T _A = –40°C to +85°C		Unit
			Min	Max	
V _{IH}	HIGH Level Input Voltage (Note 2.)	2.7V ≤ V _{CC} ≤ 3.6V	2.0		V
V _{IL}	LOW Level Input Voltage (Note 2.)	2.7V ≤ V _{CC} ≤ 3.6V		0.8	V
V _{OH}	HIGH Level Output Voltage	2.7V ≤ V _{CC} ≤ 3.6V; I _{OH} = –100μA	V _{CC} – 0.2		V
		V _{CC} = 2.7V; I _{OH} = –12mA	2.2		
		V _{CC} = 3.0V; I _{OH} = –18mA	2.4		
		V _{CC} = 3.0V; I _{OH} = –24mA	2.2		
V _{OL}	LOW Level Output Voltage	2.7V ≤ V _{CC} ≤ 3.6V; I _{OL} = 100μA		0.2	V
		V _{CC} = 2.7V; I _{OL} = 12mA		0.4	
		V _{CC} = 3.0V; I _{OL} = 16mA		0.4	
		V _{CC} = 3.0V; I _{OL} = 24mA		0.55	
I _I	Input Leakage Current	2.7V ≤ V _{CC} ≤ 3.6V; 0V ≤ V _I ≤ 5.5V		±5.0	μA
I _{OZ}	3–State Output Current	2.7 ≤ V _{CC} ≤ 3.6V; 0V ≤ V _O ≤ 5.5V; V _I = V _{IH} or V _{IL}		±5.0	μA
I _{OFF}	Power–Off Leakage Current	V _{CC} = 0V; V _I or V _O = 5.5V		10	μA
I _{CC}	Quiescent Supply Current	2.7 ≤ V _{CC} ≤ 3.6V; V _I = GND or V _{CC}		20	μA
		2.7 ≤ V _{CC} ≤ 3.6V; 3.6 ≤ V _I or V _O ≤ 5.5V		±20	μA
ΔI _{CC}	Increase in I _{CC} per Input	2.7 ≤ V _{CC} ≤ 3.6V; V _{IH} = V _{CC} – 0.6V		500	μA

2. These values of V_I are used to test DC electrical characteristics only.

AC CHARACTERISTICS ($t_R = t_F = 2.5\text{ns}$; $C_L = 50\text{pF}$; $R_L = 500\Omega$)

Symbol	Parameter	Waveform	Limits				Unit
			$T_A = -40^\circ\text{C to } +85^\circ\text{C}$				
			$V_{CC} = 3.0\text{V to } 3.6\text{V}$		$V_{CC} = 2.7\text{V}$		
			Min	Max	Min	Max	
t_{PLH} t_{PHL}	Propagation Delay An to Bn or Bn to An	1	1.5	5.4	1.5	6.0	ns
t_{PLH} t_{PHL}	Propagation Delay LEBAn to An or LEABn to Bn	4	1.5	7.0	1.5	8.2	ns
t_{PZH} t_{PZL}	Output Enable Time OEBAAn to An or OEABn to Bn	2	1.5	6.5	1.5	7.0	ns
t_{PHZ} t_{PLZ}	Output Disable Time OEBAAn to An or OEABn to Bn	2	1.5	6.5	1.5	7.0	ns
t_{PZH} t_{PZL}	Output Enable Time EBAAn to An or EABn to Bn	2	1.5	6.5	1.5	7.0	ns
t_{PHZ} t_{PLZ}	Output Disable Time EBAAn to An or EABn to Bn	2	1.5	6.5	1.5	7.0	ns
t_s	Setup Time, HIGH to LOW Data to LE _{xxn}	4	2.5		2.5		ns
t_h	Hold Time, HIGH to LOW Data to LE _{xxn}	4	1.5		1.5		ns
t_s	Setup Time, HIGH to LOW Data to E _{xxn}	4	2.5		2.5		ns
t_h	Hold Time, HIGH to LOW Data to E _{xxn}	4	1.5		1.5		ns
t_w	Latch Enable or Enable Pulse Width, LOW	4	3.0		3.0		ns
t_{OSHL} t_{OSLH}	Output-to-Output Skew (Note 3.)			1.0			ns

3. Skew is defined as the absolute value of the difference between the actual propagation delay for any two separate outputs of the same device. The specification applies to any outputs switching in the same direction, either HIGH-to-LOW (t_{OSHL}) or LOW-to-HIGH (t_{OSLH}); parameter guaranteed by design.

DYNAMIC SWITCHING CHARACTERISTICS

Symbol	Characteristic	Condition	$T_A = +25^\circ\text{C}$			Unit
			Min	Typ	Max	
V_{OLP}	Dynamic LOW Peak Voltage (Note 4.)	$V_{CC} = 3.3\text{V}$, $C_L = 50\text{pF}$, $V_{IH} = 3.3\text{V}$, $V_{IL} = 0\text{V}$		0.8		V
V_{OLV}	Dynamic LOW Valley Voltage (Note 4.)	$V_{CC} = 3.3\text{V}$, $C_L = 50\text{pF}$, $V_{IH} = 3.3\text{V}$, $V_{IL} = 0\text{V}$		0.8		V

4. Number of outputs defined as "n". Measured with "n-1" outputs switching from HIGH-to-LOW or LOW-to-HIGH. The remaining output is measured in the LOW state.

CAPACITIVE CHARACTERISTICS

Symbol	Parameter	Condition	Typical	Unit
C_{IN}	Input Capacitance	$V_{CC} = 3.3\text{V}$, $V_I = 0\text{V}$ or V_{CC}	7	pF
$C_{I/O}$	Input/Output Capacitance	$V_{CC} = 3.3\text{V}$, $V_I = 0\text{V}$ or V_{CC}	8	pF
C_{PD}	Power Dissipation Capacitance	10MHz, $V_{CC} = 3.3\text{V}$, $V_I = 0\text{V}$ or V_{CC}	20	pF

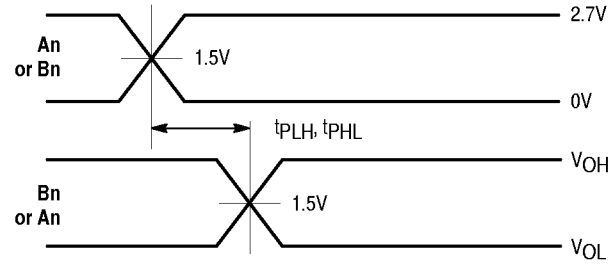

WAVEFORM 1 – A/B to B/A PROPAGATION DELAYS
 $t_R = t_F = 2.5\text{ns}$, 10% to 90%; $f = 1\text{MHz}$; $t_W = 500\text{ns}$

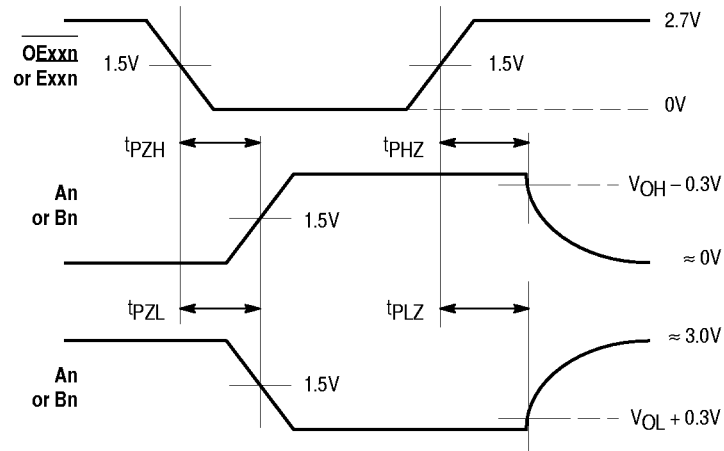

WAVEFORM 2 – OExx/Exx to A or B OUTPUT ENABLE AND DISABLE TIMES
 $t_R = t_F = 2.5\text{ns}$, 10% to 90%; $f = 1\text{MHz}$; $t_W = 500\text{ns}$

Figure 1. AC Waveforms

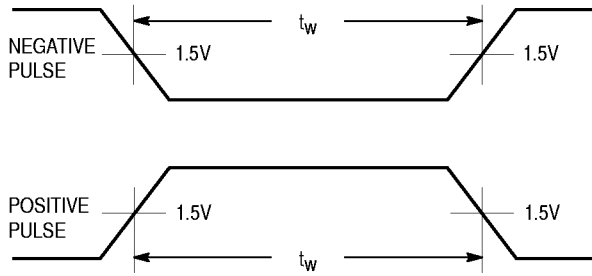

WAVEFORM 3 – INPUT PULSE DEFINITION
 $t_R = t_F = 2.5\text{ns}$, 10% to 90% of 0V to 2.7V

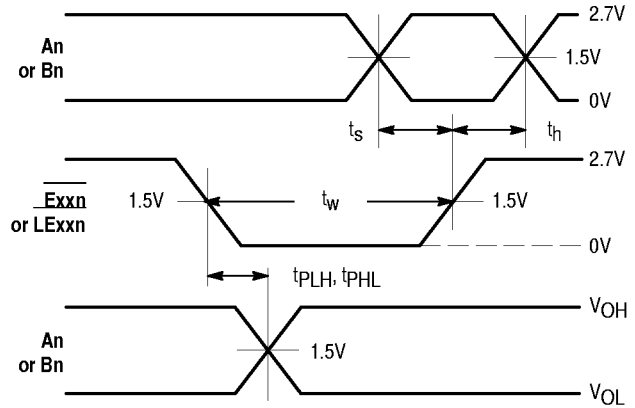

WAVEFORM 4 – Enable to A or B PROPAGATION DELAYS, Enable MINIMUM PULSE WIDTH, A or B to Enable SETUP AND HOLD TIMES
 $t_R = t_F = 2.5\text{ns}$, 10% to 90%; $f = 1\text{MHz}$; $t_w = 500\text{ns}$ except when noted

Figure 2. AC Waveforms (continued)

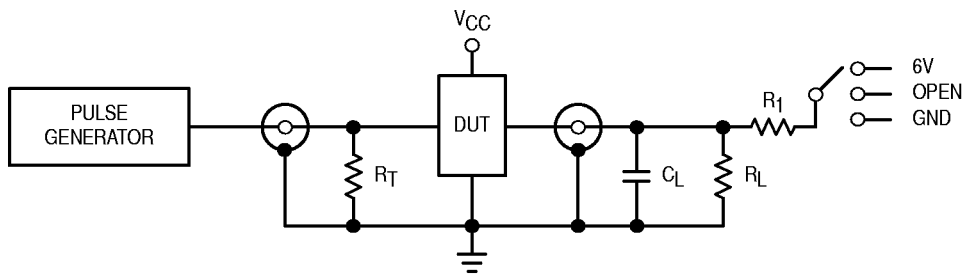

TEST	SWITCH
t_{PLH} , t_{PHL}	Open
t_{PZL} , t_{PLZ}	6V
Open Collector/Drain t_{PLH} and t_{PHL}	6V
t_{PZH} , t_{PHZ}	GND

$C_L = 50\text{pF}$ or equivalent (Includes jig and probe capacitance)
 $R_L = R_1 = 500\Omega$ or equivalent
 $R_T = Z_{OUT}$ of pulse generator (typically 50Ω)

Figure 3. Test Circuit

OUTLINE DIMENSIONS

DT SUFFIX
 PLASTIC TSSOP PACKAGE
 CASE 1202-01
 ISSUE A

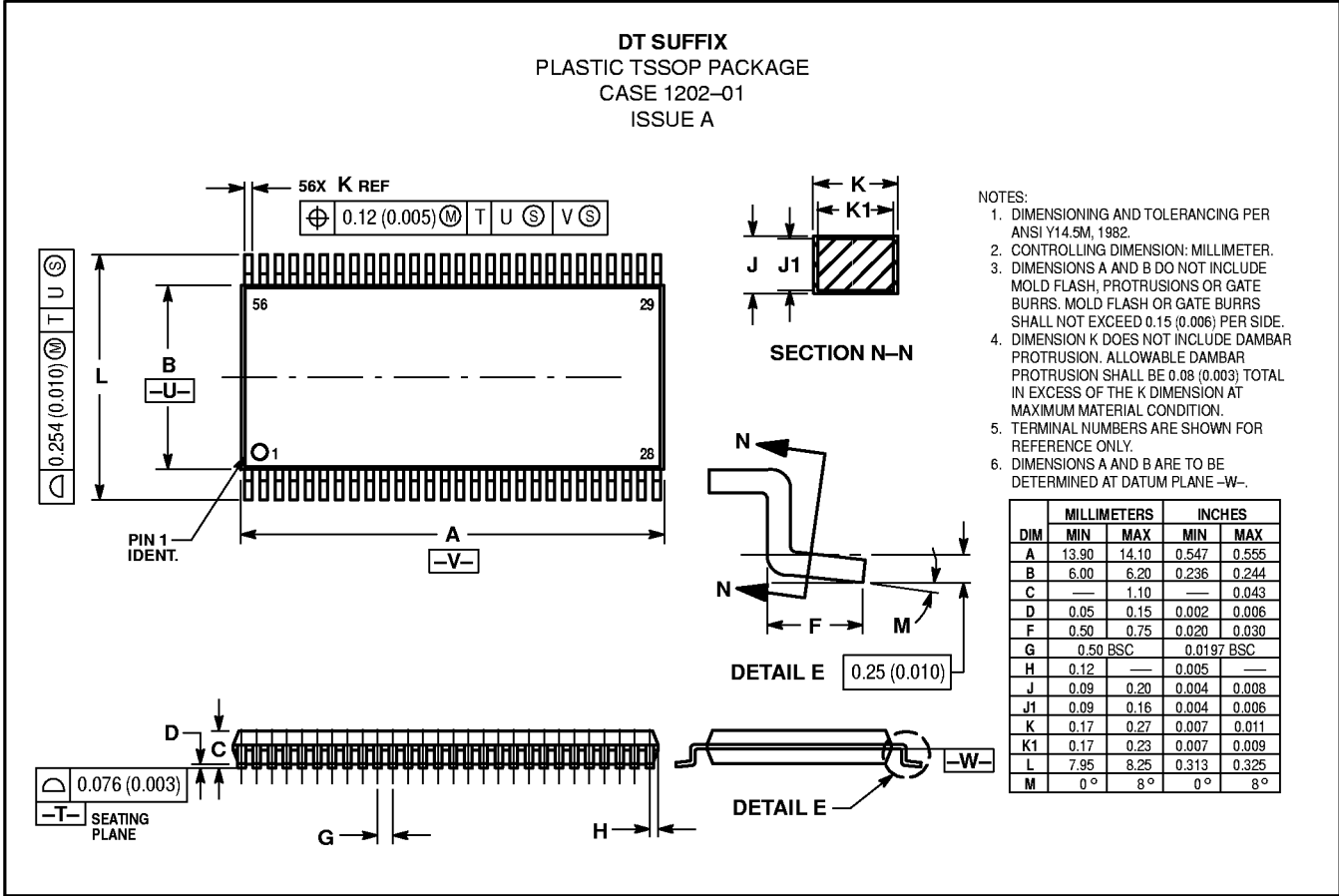

Motorola reserves the right to make changes without further notice to any products herein. Motorola makes no warranty, representation or guarantee regarding the suitability of its products for any particular purpose, nor does Motorola assume any liability arising out of the application or use of any product or circuit, and specifically disclaims any and all liability, including without limitation consequential or incidental damages. "Typical" parameters which may be provided in Motorola data sheets and/or specifications can and do vary in different applications and actual performance may vary over time. All operating parameters, including "Typicals" must be validated for each customer application by customer's technical experts. Motorola does not convey any license under its patent rights nor the rights of others. Motorola products are not designed, intended, or authorized for use as components in systems intended for surgical implant into the body, or other applications intended to support or sustain life, or for any other application in which the failure of the Motorola product could create a situation where personal injury or death may occur. Should Buyer purchase or use Motorola products for any such unintended or unauthorized application, Buyer shall indemnify and hold Motorola and its officers, employees, subsidiaries, affiliates, and distributors harmless against all claims, costs, damages, and expenses, and reasonable attorney fees arising out of, directly or indirectly, any claim of personal injury or death associated with such unintended or unauthorized use, even if such claim alleges that Motorola was negligent regarding the design or manufacture of the part. Motorola and are registered trademarks of Motorola, Inc. Motorola, Inc. is an Equal Opportunity/Affirmative Action Employer.

How to reach us:
USA/EUROPE/Locations Not Listed: Motorola Literature Distribution;
 P.O. Box 5405; Denver, Colorado 80217. 303-675-2140 or 1-800-441-2447

Mfax™: RMFAX0@email.sps.mot.com – TOUCHTONE 602-244-6609
INTERNET: http://Design-NET.com

JAPAN: Nippon Motorola Ltd.; Tatsumi-SPD-JLDC, 6F Seibu-Butsuryu-Center,
 3-14-2 Tatsumi Koto-Ku, Tokyo 135, Japan. 81-3-3521-8315

ASIA/PACIFIC: Motorola Semiconductors H.K. Ltd.; 8B Tai Ping Industrial Park,
 51 Ting Kok Road, Tai Po, N.T., Hong Kong. 852-26629298

