

## 54LS86, 54S86 Gates

Military Logic Products

Quad Two-Input Exclusive-OR Gates

Product Specification

### FUNCTION TABLE

INPUTS		OUTPUT
A	B	Y
L	L	L
L	H	H
H	L	H
H	H	L

H = High voltage level  
L = Low voltage level

### ORDERING INFORMATION

DESCRIPTION	ORDER CODE
14-Pin Ceramic DIP	54LS86/BCA, 54S86/BCA
14-Pin Ceramic Flat Pack	54LS86/BDA, 54S86/BDA
Ceramic LLCC	54LS86/B2A, 54S86/B2A

### INPUT AND OUTPUT LOADING AND FAN-OUT TABLE

PINS	DESCRIPTION	54S	54LS
A, B	Inputs	1SUL	1LSUL
Y	Output	10SUL	10LSUL

NOTE: Where a 54S Unit Load (SUL) is 50 $\mu$ A  $I_{IH}$  and -2.0mA  $I_{IL}$ , and a 54LS Unit Load (LSUL) is 20 $\mu$ A  $I_{IH}$  and -0.4mA  $I_{IL}$ .

### ABSOLUTE MAXIMUM RATINGS (Over operating free-air temperature range unless otherwise noted.)

SYMBOL	PARAMETER	54LS	54S	UNIT
$V_{CC}$	Supply voltage	7.0	7.0	V
$V_i$	Input voltage range	-0.5 to +7.0	-0.5 to +5.5	V
$I_i$	Input current range	-30 to +1	-30 to +5	mA
$V_o$	Voltage applied to output in High output state range	-0.5 to + $V_{CC}$	-0.5 to + $V_{CC}$	V
$T_{STG}$	Storage temperature range	-65 to +150	-65 to +150	$^{\circ}$ C

### PIN CONFIGURATION

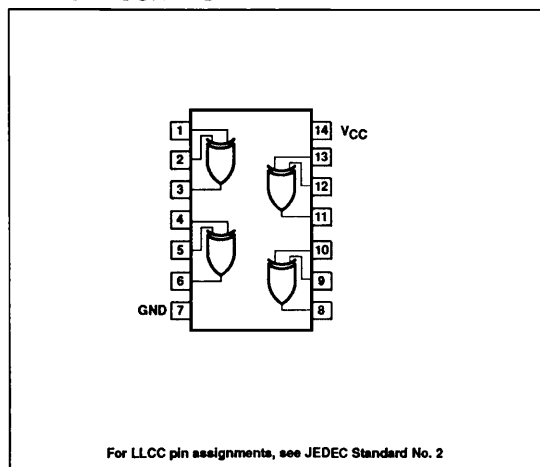

### LOGIC SYMBOL

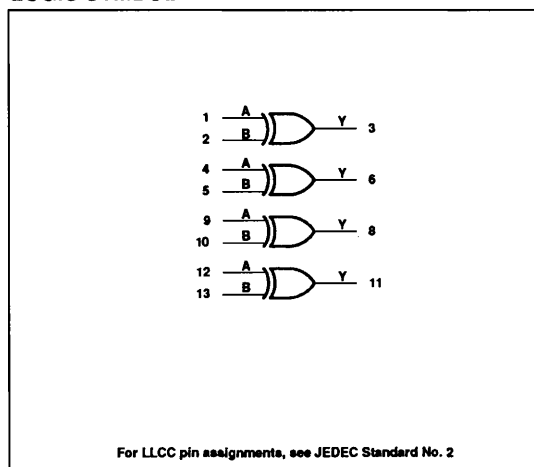

Gates

54LS86, 54S86

RECOMMENDED OPERATING CONDITIONS

SYMBOL	PARAMETER	54LS			54S			UNIT
		Min	Nom	Max	Min	Nom	Max	
V <sub>CC</sub>	Supply voltage	4.5	5.0	5.5	4.5	5.0	5.5	V
V <sub>IH</sub>	High-level input voltage	2.0			2.0			V
V <sub>IL</sub>	Low-level input voltage			+0.7			+0.8	V
			+125°C	+0.7			+0.7	V
I <sub>IK</sub>	Input clamp current			-18			-18	mA
I <sub>OH</sub>	High-level output current			-400			-1000	μA
I <sub>OL</sub>	Low-level output current			4			20	mA
T <sub>A</sub>	Operating free-air temperature range	-55		+125	-55		+125	°C

DC ELECTRICAL CHARACTERISTICS (Over recommended operating free-air temperature range unless otherwise noted.)

SYMBOL	PARAMETER	TEST CONDITIONS <sup>1</sup>	54LS86			54S86			UNIT
			Min	Typ <sup>2</sup>	Max	Min	Typ <sup>2</sup>	Max	
V <sub>OH</sub>	High-level output voltage	V <sub>CC</sub> = Min, V <sub>IH</sub> = Min, V <sub>IL</sub> = Max, I <sub>OH</sub> = Max	2.5	3.4		2.5	3.4		V
V <sub>OL</sub>	Low-level output voltage	V <sub>CC</sub> = Min, V <sub>IH</sub> = Min, V <sub>IL</sub> = Max, I <sub>OL</sub> = Max		0.25	0.4			0.5	V
					0.4			0.45	V
V <sub>IK</sub>	Input clamp voltage	V <sub>CC</sub> = Min, I <sub>I</sub> = I <sub>IK</sub>			-1.5			-1.2	V
I <sub>IH2</sub>	Input current at maximum input voltage	V <sub>CC</sub> = Max	V <sub>I</sub> = 5.5V					1.0	mA
			V <sub>I</sub> = 7.0V			0.2			mA
I <sub>IH1</sub>	High-level input current	V <sub>CC</sub> = Max, V <sub>I</sub> = 2.7V			40			50	μA
I <sub>IL</sub>	Low-level input current	V <sub>CC</sub> = Max	V <sub>I</sub> = 0.4V		-0.8				mA
			V <sub>I</sub> = 0.5V					-2.0	mA
I <sub>OS</sub>	Short-circuit output current <sup>3</sup>	V <sub>CC</sub> = Max	-20		-110	-40		-100	mA
I <sub>CC</sub>	Supply current <sup>4</sup> (total)	V <sub>CC</sub> = Max		0.1	10		50	75	mA

AC ELECTRICAL CHARACTERISTICS T<sub>A</sub> = 25°C, V<sub>CC</sub> = 5.0V

SYMBOL	PARAMETER	TEST CONDITIONS	54LS		54S <sup>5</sup>		UNIT
			C <sub>L</sub> = 15pF		C <sub>L</sub> = 15pF		
			Min	Max	Min	Max	
t <sub>PLH</sub> t <sub>PHL</sub>	Propagation delay A or B to output	Other input Low Waveform 2		23 17		10.5 10	ns ns
				30 22		10.5 10	ns ns

AC ELECTRICAL CHARACTERISTICS T<sub>A</sub> = 25°C, V<sub>CC</sub> = 5.0V

SYMBOL	PARAMETER	TEST CONDITIONS	54LS <sup>5</sup>		54S		UNIT
			C <sub>L</sub> = 50pF		C <sub>L</sub> = 50pF		
			Min	Max	Min	Max	
t <sub>PLH</sub> t <sub>PHL</sub>	Propagation delay A or B to output	Other input Low Waveform 2		25 22		12.5 12	ns ns
				35 27		12.5 12	ns ns

# Gates

# 54LS86, 54S86

## AC ELECTRICAL CHARACTERISTICS $T_A = -55^\circ\text{C}$ and $+125^\circ\text{C}$ , $V_{CC} = 5.0\text{V}^5$

SYMBOL	PARAMETER	TEST CONDITIONS	54LS		54S		UNIT
			$C_L = 50\text{pF}$		$C_L = 50\text{pF}$		
			Min	Max	Min	Max	
$t_{PLH}$ $t_{PHL}$	Propagation delay A or B to output	Other input Low Waveform 2		33 29		16.5 15.5	ns ns
$t_{PLH}$ $t_{PHL}$	Propagation delay A or B to output	Other input High Waveform 1		46 35		16.5 15.5	ns ns

**NOTES:**

1. For conditions shown as Min or Max, use the appropriate value specified under recommended operating conditions for the applicable type and function table operating mode.
2. All typical values are at  $V_{CC} = 5\text{V}$ ,  $T_A = 25^\circ\text{C}$ .
3. Not more than one output should be shorted at a time and duration of the short circuit should not exceed one second.
4.  $I_{CC}$  is measured with inputs grounded and outputs open.
5. These parameters are guaranteed, but not tested.

## AC WAVEFORMS

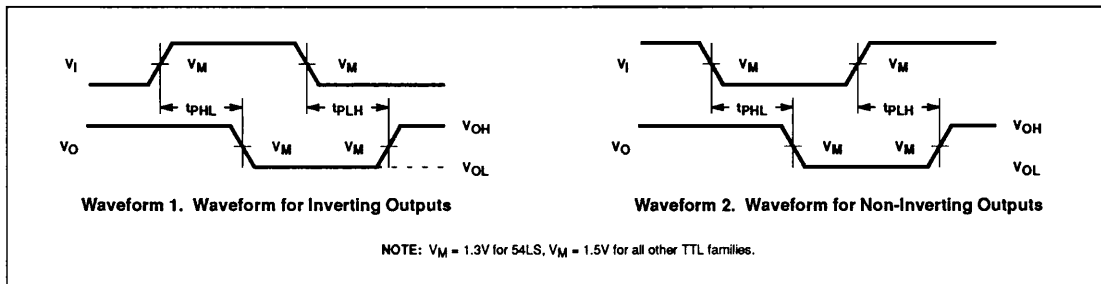

## TEST CIRCUIT AND WAVEFORM

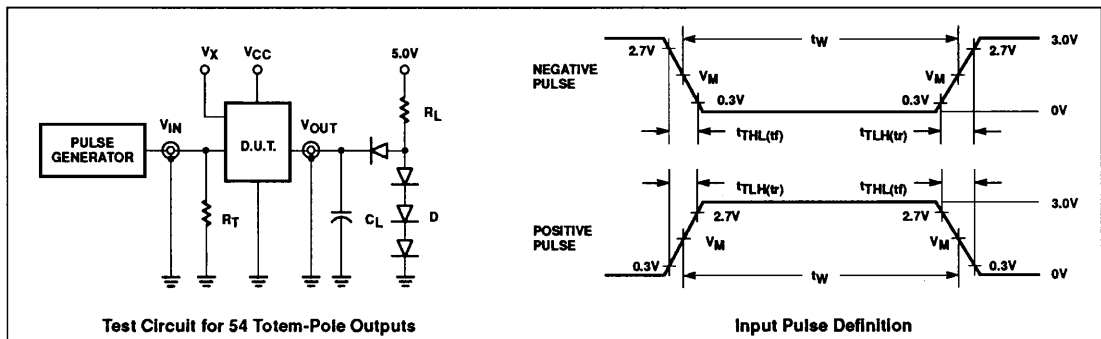

FAMILY	INPUT PULSE CHARACTERISTICS					
	$R_L$	$V_M$	Rep. Rate	$T_W$	$T_{TLH}$	$T_{THL}$
54LSXXX	2.0k $\Omega$	1.3V	1MHz	500ns	$\leq 15\text{ns}$	$\leq 6\text{ns}$
54SXXX	280 $\Omega$	1.5V	1MHz	500ns	$\leq 2.5\text{ns}$	$\leq 2.5\text{ns}$

**DEFINITIONS:**

- $C_L$  = Load capacitance includes jig and probe capacitance; see AC Characteristics for value.
- $R_T$  = Termination resistance should be equal to  $Z_{OUT}$  of Pulse Generators.
- D = Diodes are 1N916, 1N3064, or equivalent.
- $V_X$  = Undocked pins must be held at  $\leq 0.8\text{V}$ ,  $\geq 2.7\text{V}$  or open per FunctionTable.