



MM54C906/MM74C906 Hex Open Drain N-Channel Buffers

MM54C907/MM74C907 Hex Open Drain P-Channel Buffers

General Description

These buffers employ monolithic CMOS technology in achieving open drain outputs. The MM54C906/MM74C906 consists of six inverters driving six N-channel devices; and the MM54C907/MM74C907 consists of six inverters driving six P-channel devices. The open drain feature of these buffers makes level shifting or wire AND and wire OR functions by just the addition of pull-up or pull-down resistors. All inputs are protected from static discharge by diode clamps to V_{CC} and to ground.

Features

- Wide supply voltage range
- Guaranteed noise margin
- High noise immunity
- High current sourcing and sinking open drain outputs

3V to 15V
1V
0.45 V_{CC} (typ.)

Connection and Logic Diagrams

Dual-In-Line Package

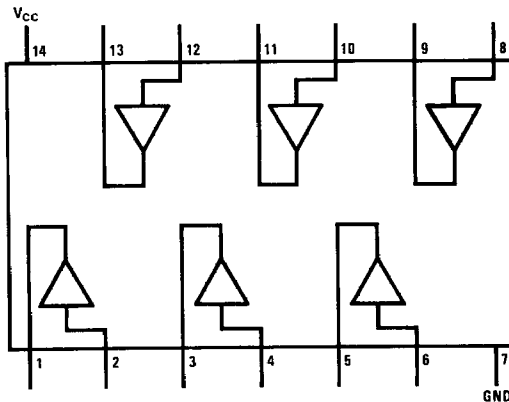

TL/F/5911-1

Top View

Order Number MM54C906*, MM54C907*, MM74C906* or MM74C907*

*Please look into Section 8, Appendix D for availability of various package types.

MM54C906/MM74C906

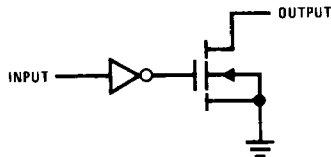

TL/F/5911-2

MM54C907/MM74C907

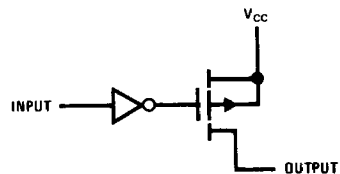

TL/F/5911-3

Absolute Maximum Ratings (Note 1)

If Military/Aerospace specified devices are required, contact the National Semiconductor Sales Office/Distributors for availability and specifications.

Voltage at Any Input Pin	-0.3V to $V_{CC} + 0.3V$
Voltage at Any Output Pin	-0.3V to +18V
MM54C906/MM74C906	$V_{CC} - 18$ to $V_{CC} + 0.3V$
MM54C907/MM74C907	
Operating Temperature Range	-55°C to +125°C
MM54C906/MM54C907	-40°C to +85°C
MM74C906/MM74C907	

Storage Temperature Range	-65°C to +150°C
Power Dissipation	
Dual-In-Line	700 mW
Small Outline	500 mW
Operating V_{CC} Range	3V to 15V
Absolute Maximum V_{CC}	18V
Lead Temperature (T_L)	260°C
(Soldering, 10 seconds)	

DC Electrical Characteristics Min/Max limits apply across temperature range unless otherwise noted

Symbol	Parameter	Conditions	Min	Typ	Max	Units
CMOS TO CMOS						
$V_{IN(1)}$	Logical "1" Input Voltage	$V_{CC} = 5V$ $V_{CC} = 10V$	3.5 8.0			V V
$V_{IN(0)}$	Logical "0" Input Voltage	$V_{CC} = 5V$ $V_{CC} = 10V$			1.5 2	V V
$I_{IN(1)}$	Logical "1" Input Current	$V_{CC} = 15V, V_{IN} = 15V$		0.005	1	μA
$I_{IN(0)}$	Logical "0" Input Current	$V_{CC} = 15V, V_{IN} = 0V$	-1.0	-0.005		μA
I_{CC}	Supply Current	$V_{CC} = 15V, \text{Output Open}$		0.05	15	μA
	Output Leakage					
	MM54C906	$V_{CC} = 4.5V, V_{IN} = V_{CC} - 1.5V$ $V_{CC} = 4.5V, V_{OUT} = 18V$		0.005	5	μA
	MM74C906	$V_{CC} = 4.75V, V_{IN} = V_{CC} - 1.5V$ $V_{CC} = 4.75V, V_{OUT} = 18V$		0.005	5	μA
	MM54C907	$V_{CC} = 4.5V, V_{IN} = 1V + 0.1 V_{CC}$ $V_{CC} = 4.5V, V_{OUT} = V_{CC} - 18V$		0.005	5	μA
	MM74C907	$V_{CC} = 4.75V, V_{IN} = 1V + 0.1 V_{CC}$ $V_{CC} = 4.75V, V_{OUT} = V_{CC} - 18V$		0.005	5	μA
CMOS/LPTTL INTERFACE						
$V_{IN(1)}$	Logical "1" Input Voltage	54C, $V_{CC} = 4.5V$ 74C, $V_{CC} = 4.75V$	$V_{CC} - 1.5V$ $V_{CC} - 1.5V$			V V
$V_{IN(0)}$	Logical "0" Input Voltage	54C, $V_{CC} = 4.5V$ 74C, $V_{CC} = 4.75V$			0.8 0.8	V V
OUTPUT DRIVE CURRENT						
	MM54C906	$V_{CC} = 4.5V, V_{IN} = 1V + 0.1 V_{CC}$ $V_{CC} = 4.5V, V_{OUT} = 0.5V$ $V_{CC} = 4.5V, V_{OUT} = 1.0V$	2.1 4.2	8.0 12.0		mA mA
	MM74C906	$V_{CC} = 4.75V, V_{IN} = 1V + 0.1 V_{CC}$ $V_{CC} = 4.75V, V_{OUT} = 0.5V$ $V_{CC} = 4.75V, V_{OUT} = 1.0V$	2.1 4.2	8.0 12.0		mA mA
	MM54C907	$V_{CC} = 4.5V, V_{IN} = V_{CC} - 1.5V$ $V_{CC} = 4.5V, V_{OUT} = V_{CC} - 0.5V$ $V_{CC} = 4.5V, V_{OUT} = V_{CC} - 1V$	-1.05 -2.1	-1.5 -3.0		mA mA
	MM74C907	$V_{CC} = 4.75V, V_{IN} = V_{CC} - 1.5V$ $V_{CC} = 4.75V, V_{OUT} = V_{CC} - 0.5V$ $V_{CC} = 4.75V, V_{OUT} = V_{CC} - 1V$	-1.05 -2.1	-1.5 -3.0		mA mA
	MM54C906/MM74C906	$V_{CC} = 10V, V_{IN} = 2V$ $V_{CC} = 10V, V_{OUT} = 0.5V$ $V_{CC} = 10V, V_{OUT} = 1V$	4.2 8.4	-20 -30		mA mA
	MM54C907/MM74C907	$V_{CC} = 10V, V_{IN} = 8V$ $V_{CC} = 10V, V_{OUT} = 9.5V$ $V_{CC} = 10V, V_{OUT} = 9V$	-2.1 -4.2	-4.0 -8.0		mA mA

AC Electrical Characteristics* $T_A = 25^\circ\text{C}$, $C_L = 50\text{ pF}$, unless otherwise specified

Symbol	Parameter	Conditions	Min	Typ	Max	Units
t_{pd}	Propagation Delay Time to a Logical "0" MM54C906/MM74C906	$V_{CC} = 5.0\text{V}$, $R = 10\text{k}$			150	ns
		$V_{CC} = 10\text{V}$, $R = 10\text{k}$			75	ns
		$V_{CC} = 5.0\text{V}$ (Note 4)			$150 + 0.7 RC$	ns
		$V_{CC} = 10\text{V}$ (Note 4)			$75 + 0.7 RC$	ns
t_{pd}	Propagation Delay Time to a Logical "1" MM54C906/MM74C906	$V_{CC} = 5.0\text{V}$ (Note 4)			$150 + 0.7 RC$	ns
		$V_{CC} = 10\text{V}$ (Note 4)			$75 + 0.7 RC$	ns
		$V_{CC} = 5.0\text{V}$, $R = 10\text{k}$			150	ns
		$V_{CC} = 10\text{V}$, $R = 10\text{k}$			75	ns
C_{IN}	Input Capacitance	(Note 2)		5.0		pF
C_{OUT}	Output Capacity	(Note 2)		20		pF
C_{PD}	Power Dissipation Capacity	(Note 3) Per Buffer		30		pF

*AC Parameters are guaranteed by DC correlated testing.

Note 1: "Absolute Maximum Ratings" are those values beyond which the safety of the device cannot be guaranteed. Except for "Operating Temperature Range" they are not meant to imply that the devices should be operated at these limits. The table of "Electrical Characteristics" provides conditions for actual device operation.

Note 2: Capacitance is guaranteed by periodic testing.

Note 3: C_{PD} determines the no load AC power consumption of any CMOS device. For complete explanation see 54C/74C Family Characteristics Application Note, AN-90. (Assumes outputs are open).

Note 4: "C" used in calculating propagation includes output load capacity (C_L) plus device output capacity (C_{OUT}).

Typical Applications

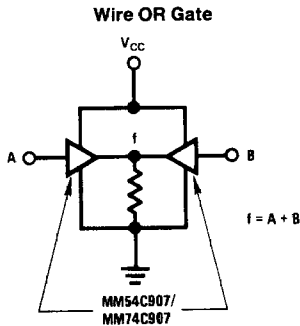

TL/F/5911-4

Note: Can be extended to more than 2 inputs.

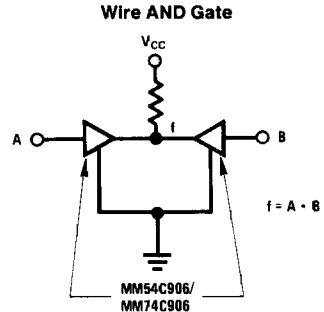

TL/F/5911-5

Note: Can be extended to more than 2 inputs.

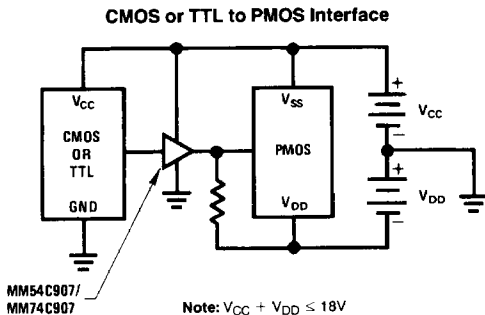

TL/F/5911-6

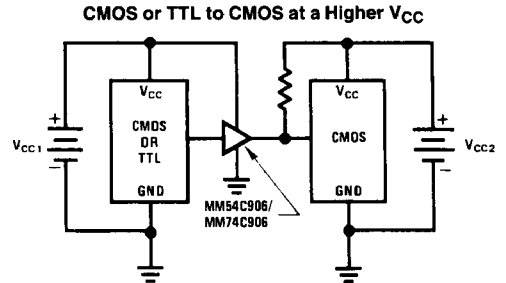

TL/F/5911-7