



Integrated Device Technology, Inc.

FAST CMOS 16-BIT REGISTER (3-STATE)

IDT54/74FCT16374T/AT/CT/ET
IDT54/74FCT162374T/AT/CT/ET

FEATURES:

• Common features:

- 0.5 MICRON CMOS Technology
- **High-speed, low-power CMOS replacement for ABT functions**
- **Typical tsk(o) (Output Skew) < 250ps**
- **Low input and output leakage $\leq 1\mu\text{A}$ (max.)**
- ESD > 2000V per MIL-STD-883, Method 3015; > 200V using machine model (C = 200pF, R = 0)
- Packages include 25 mil pitch SSOP, 19.6 mil pitch TSSOP, 15.7 mil pitch TVSOP and 25 mil pitch Cerpack
- Extended commercial range of -40°C to +85°C
- Vcc = 5V $\pm 10\%$

• Features for FCT16374T/AT/CT/ET:

- High drive outputs (-32mA IOH, 64mA IOL)
- Power off disable outputs permit "live insertion"
- Typical VOLP (Output Ground Bounce) < 1.0V at Vcc = 5V, TA = 25°C

• Features for FCT162374T/AT/CT/ET:

- Balanced Output Drivers: $\pm 24\text{mA}$ (commercial), $\pm 16\text{mA}$ (military)
- Reduced system switching noise
- Typical VOLP (Output Ground Bounce) < 0.6V at Vcc = 5V, TA = 25°C

DESCRIPTION:

The FCT16374T/AT/CT/ET and FCT162374T/AT/CT/ET 16-bit edge-triggered D-type registers are built using advanced dual metal CMOS technology. These high-speed, low-power registers are ideal for use as buffer registers for data synchronization and storage. The Output Enable (xOE) and clock (xCLK) controls are organized to operate each device as two 8-bit registers or one 16-bit register with common clock. Flow-through organization of signal pins simplifies layout. All inputs are designed with hysteresis for improved noise margin.

The FCT16374T/AT/CT/ET are ideally suited for driving high-capacitance loads and low-impedance backplanes. The output buffers are designed with power off disable capability to allow "live insertion" of boards when used as backplane drivers.

The FCT162374T/AT/CT/ET have balanced output drive with current limiting resistors. This offers low ground bounce, minimal undershoot, and controlled output fall times—reducing the need for external series terminating resistors. The FCT162374T/AT/CT/ET are plug-in replacements for the FCT16374T/AT/CT/ET and ABT16374 for on-board bus interface applications.

FUNCTIONAL BLOCK DIAGRAM

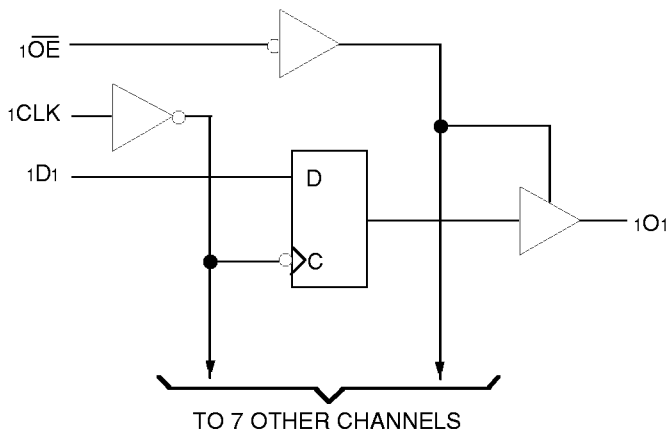

2542 drw 01

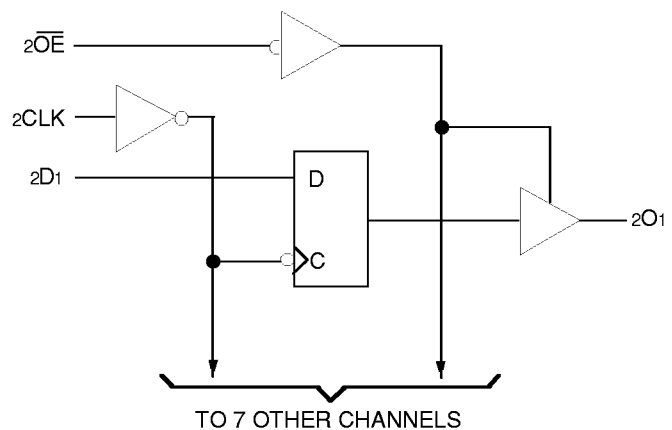

2542 drw 01

The IDT logo is a registered trademark of Integrated Device Technology, Inc.

MILITARY AND INDUSTRIAL TEMPERATURE RANGES

FEBRUARY 1997

PIN CONFIGURATIONS

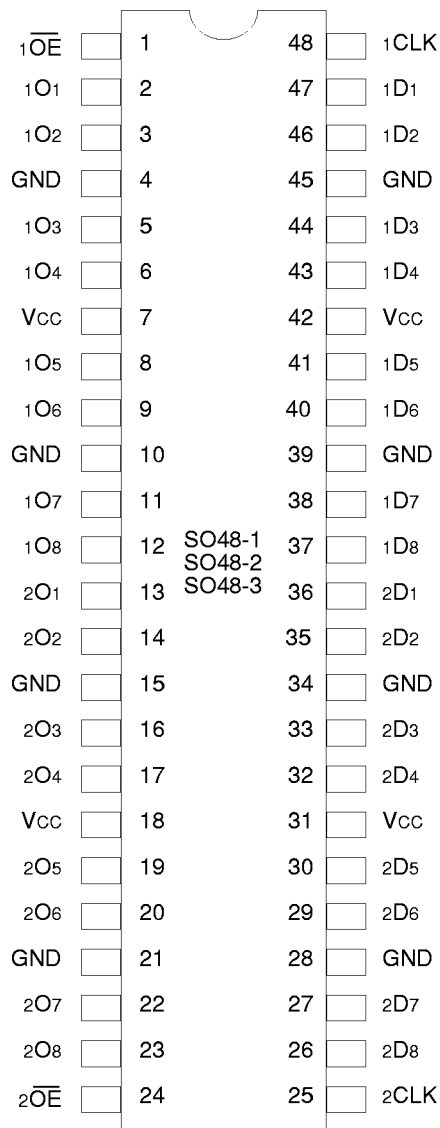

**SSOP/
TSSOP/TVSOP
TOP VIEW**

2542 drw 03

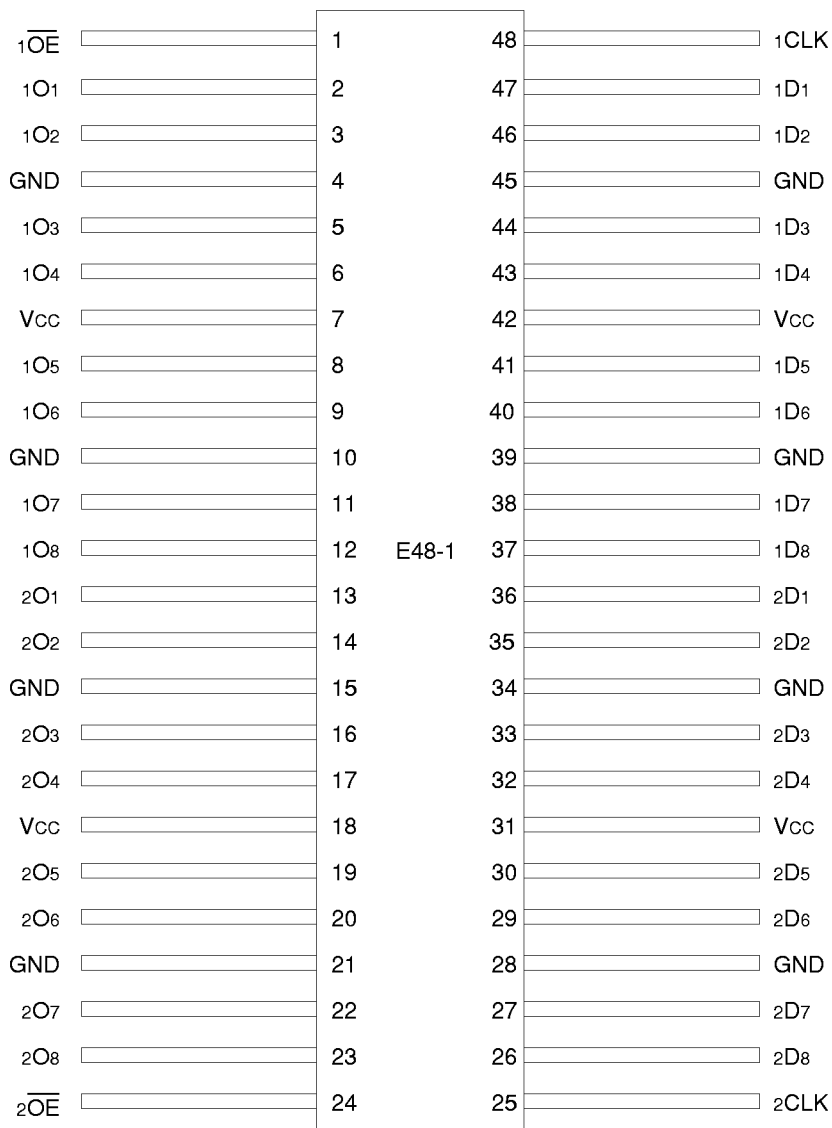

**CERPACK
TOP VIEW**

2542 drw 04

PIN DESCRIPTION

Pin Names	Description
xDx	Data Inputs
xCLK	Clock Inputs
xOx	3-State Outputs.
x \overline{OE}	3-State Output Enable Input (Active LOW)

2542 tbl 01

FUNCTION TABLE⁽¹⁾

Function	Inputs			Outputs
	xDx	xCLK	x \overline{OE}	xOx
Hi-Z	X	L	H	Z
	X	H	H	Z
Load Register	L	↑	L	L
	H	↑	L	H
	L	↑	H	Z
	H	↑	H	Z

NOTE:

- H = HIGH Voltage Level
L = LOW Voltage Level
X = Don't Care
Z = High Impedance
↑ = LOW-to-HIGH Transition

2542 tbl 02

ABSOLUTE MAXIMUM RATINGS⁽¹⁾

Symbol	Description	Max.	Unit
V _{TERM} (2)	Terminal Voltage with Respect to GND	-0.5 to +7.0	V
V _{TERM} (3)	Terminal Voltage with Respect to GND	-0.5 to V _{CC} +0.5	V
T _{STG}	Storage Temperature	-65 to +150	°C
I _{OUT}	DC Output Current	-60 to +120	mA

NOTES:

2542 lmk 03

- Stresses greater than those listed under ABSOLUTE MAXIMUM RATINGS may cause permanent damage to the device. This is a stress rating only and functional operation of the device at these or any other conditions above those indicated in the operational sections of this specification is not implied. Exposure to absolute maximum rating conditions for extended periods may affect reliability.
- All device terminals except FCT162XXXXT Output and I/O terminals.
- Output and I/O terminals for FCT162XXXXT.

CAPACITANCE (T_A = +25°C, f = 1.0MHz)

Symbol	Parameter ⁽¹⁾	Conditions	Typ.	Max.	Unit
C _{IN}	Input Capacitance	V _{IN} = 0V	3.5	6.0	pF
C _{I/O}	I/O Capacitance	V _{OUT} = 0V	3.5	8.0	pF

NOTE:

- This parameter is measured at characterization but not tested.

2542 lmk 04

DC ELECTRICAL CHARACTERISTICS OVER OPERATING RANGE

Following Conditions Apply Unless Otherwise Specified:

Commercial: TA = -40°C to +85°C, VCC = 5.0V ± 10%; Military: TA = -55°C to +125°C, VCC = 5.0V ± 10%

Symbol	Parameter	Test Conditions ⁽¹⁾		Min.	Typ. ⁽²⁾	Max.	Unit
V _{IH}	Input HIGH Level	Guaranteed Logic HIGH Level		2.0	—	—	V
V _{IL}	Input LOW Level	Guaranteed Logic LOW Level		—	—	0.8	V
I _{IH}	Input HIGH Current (Input pins) ⁽⁵⁾	V _{CC} = Max.	V _I = V _{CC}	—	—	±1	μA
	Input HIGH Current (I/O pins) ⁽⁵⁾			—	—	±1	
I _{IL}	Input LOW Current (Input pins) ⁽⁵⁾		V _I = GND	—	—	±1	
	Input LOW Current (I/O pins) ⁽⁵⁾			—	—	±1	
IOZH	High Impedance Output Current (3-State Output pins) ⁽⁵⁾	V _{CC} = Max.	V _O = 2.7V	—	—	±1	μA
IOZL			V _O = 0.5V	—	—	±1	
V _{IK}	Clamp Diode Voltage	V _{CC} = Min., I _{IN} = -18mA		—	-0.7	-1.2	V
I _{OS}	Short Circuit Current	V _{CC} = Max., V _O = GND ⁽³⁾		-80	-140	-250	mA
V _H	Input Hysteresis	—		—	100	—	mV
I _{CC1} I _{CC2} I _{CC3}	Quiescent Power Supply Current	V _{CC} = Max., V _{IN} = GND or V _{CC}		—	5	500	μA

2542 Ink 05

OUTPUT DRIVE CHARACTERISTICS FOR FCT16374T

Symbol	Parameter	Test Conditions ⁽¹⁾		Min.	Typ. ⁽²⁾	Max.	Unit
I _O	Output Drive Current	V _{CC} = Max., V _O = 2.5V ⁽³⁾		-50	—	-180	mA
V _{OH}	Output HIGH Voltage	V _{CC} = Min. V _{IN} = V _{IH} or V _{IL}	I _{OH} = -3mA	2.5	3.5	—	V
			I _{OH} = -12mA MIL. I _{OH} = -15mA COM'L.	2.4	3.5	—	V
			I _{OH} = -24mA MIL. I _{OH} = -32mA COM'L. ⁽⁴⁾	2.0	3.0	—	V
V _{OL}	Output LOW Voltage	V _{CC} = Min. V _{IN} = V _{IH} or V _{IL}	I _{OL} = 48mA MIL. I _{OL} = 64mA COM'L.	—	0.2	0.55	V
I _{OFF}	Input/Output Power Off Leakage ⁽⁵⁾	V _{CC} = 0V, V _{IN} or V _O ≤ 4.5V		—	—	±1	μA

2542 Ink 06

OUTPUT DRIVE CHARACTERISTICS FOR FCT162374T

Symbol	Parameter	Test Conditions ⁽¹⁾		Min.	Typ. ⁽²⁾	Max.	Unit
I _{ODL}	Output LOW Current	V _{CC} = 5V, V _{IN} = V _{IH} or V _{IL} , V _{OUT} = 1.5V ⁽³⁾		60	115	200	mA
I _{ODH}	Output HIGH Current	V _{CC} = 5V, V _{IN} = V _{IH} or V _{IL} , V _{OUT} = 1.5V ⁽³⁾		-60	-115	-200	mA
V _{OH}	Output HIGH Voltage	V _{CC} = Min. V _{IN} = V _{IH} or V _{IL}	I _{OH} = -16mA MIL. I _{OH} = -24mA COM'L.	2.4	3.3	—	V
V _{OL}	Output LOW Voltage	V _{CC} = Min. V _{IN} = V _{IH} or V _{IL}	I _{OL} = 16mA MIL. I _{OL} = 24mA COM'L.	—	0.3	0.55	V

2542 Ink 07

NOTES:

- For conditions shown as Max. or Min., use appropriate value specified under Electrical Characteristics for the applicable device type.
- Typical values are at V_{CC} = 5.0V, +25°C ambient.
- Not more than one output should be tested at one time. Duration of the test should not exceed one second.
- Duration of the condition can not exceed one second.
- The test limit for this parameter is ± 5μA at TA = -55°C.

POWER SUPPLY CHARACTERISTICS

Symbol	Parameter	Test Conditions(1)		Min.	Typ.(2)	Max.	Unit
ΔI_{CC}	Quiescent Power Supply Current TTL Inputs HIGH	$V_{CC} = \text{Max.}$ $V_{IN} = 3.4V^{(3)}$		—	0.5	1.5	mA
I_{CCD}	Dynamic Power Supply Current(4)	$V_{CC} = \text{Max.}$ Outputs Open $\overline{xOE} = \text{GND}$ One Input Toggling 50% Duty Cycle	$V_{IN} = V_{CC}$ $V_{IN} = \text{GND}$	—	60	100	$\mu\text{A}/\text{MHz}$
I_C	Total Power Supply Current(6)	$V_{CC} = \text{Max.}$ Outputs Open $f_{CP} = 10\text{MHz}$ 50% Duty Cycle $\overline{xOE} = \text{GND}$ $f_i = 5\text{MHz}$ 50% Duty Cycle One Bit Toggling	$V_{IN} = V_{CC}$ $V_{IN} = \text{GND}$	—	0.6	1.5	mA
			$V_{IN} = 3.4V$ $V_{IN} = \text{GND}$	—	1.1	3.0	
		$V_{CC} = \text{Max.}$ Outputs Open $f_{CP} = 10\text{MHz}$ 50% Duty Cycle $\overline{xOE} = \text{GND}$ Sixteen Bits Toggling $f_i = 2.5\text{MHz}$ 50% Duty Cycle	$V_{IN} = V_{CC}$ $V_{IN} = \text{GND}$	—	3.0	5.5(5)	
			$V_{IN} = 3.4V$ $V_{IN} = \text{GND}$	—	7.5	19.0(5)	

NOTES:

2542 tbl 08

- For conditions shown as Max. or Min., use appropriate value specified under Electrical Characteristics for the applicable device type.
- Typical values are at $V_{CC} = 5.0V$, $+25^\circ\text{C}$ ambient.
- Per TTL driven input ($V_{IN} = 3.4V$). All other inputs at V_{CC} or GND .
- This parameter is not directly testable, but is derived for use in Total Power Supply Calculations.
- Values for these conditions are examples of the I_{CC} formula. These limits are guaranteed but not tested.
- $I_C = I_{\text{QUIESCENT}} + I_{\text{INPUTS}} + I_{\text{DYNAMIC}}$
 $I_C = I_{CC} + \Delta I_{CC} D_H N_T + I_{CCD} (f_{CP} N_{CP} / 2 + f_i N_i)$
 $I_{CC} = \text{Quiescent Current } (I_{CCL}, I_{CCH} \text{ and } I_{CCZ})$
 $\Delta I_{CC} = \text{Power Supply Current for a TTL High Input } (V_{IN} = 3.4V)$
 $D_H = \text{Duty Cycle for TTL Inputs High}$
 $N_T = \text{Number of TTL Inputs at } D_H$
 $I_{CCD} = \text{Dynamic Current Caused by an Input Transition Pair (HLH or LHL)}$
 $f_{CP} = \text{Clock Frequency for Register Devices (Zero for Non-Register Devices)}$
 $N_{CP} = \text{Number of Clock Inputs at } f_{CP}$
 $f_i = \text{Input Frequency}$
 $N_i = \text{Number of Inputs at } f_i$

SWITCHING CHARACTERISTICS OVER OPERATING RANGE

Symbol	Parameter	Condition ⁽¹⁾	FCT16374T/162374T				FCT16374AT/162374AT				Unit
			Com'l.		Mil.		Com'l.		Mil.		
			Min. ⁽²⁾	Max.	Min. ⁽²⁾	Max.	Min. ⁽²⁾	Max.	Min. ⁽²⁾	Max.	
tPLH tPHL	Propagation Delay xCLK to xOx	CL = 50pF RL = 500Ω	2.0	10.0	2.0	11.0	2.0	6.5	2.0	7.2	ns
tPZH tPZL	Output Enable Time		1.5	12.5	1.5	14.0	1.5	6.5	1.5	7.5	ns
tPHZ tPLZ	Output Disable Time		1.5	8.0	1.5	8.0	1.5	5.5	1.5	6.5	ns
tsU	Set-up Time HIGH or LOW, xDx to xCLK		2.0	—	2.0	—	2.0	—	2.0	—	ns
tH	Hold Time HIGH or LOW, xDx to xCLK		1.5	—	1.5	—	1.5	—	1.5	—	ns
tw	xCLK Pulse Width HIGH or LOW		7.0	—	7.0	—	5.0	—	6.0	—	ns
tsk(o)	Output Skew ⁽³⁾		—	0.5	—	0.5	—	0.5	—	0.5	ns

Symbol	Parameter	Condition ⁽¹⁾	FCT16374CT/162374CT				FCT16374ET/162374ET				Unit
			Com'l.		Mil.		Com'l.		Mil.		
			Min. ⁽²⁾	Max.	Min. ⁽²⁾	Max.	Min. ⁽²⁾	Max.	Min. ⁽²⁾	Max.	
tPLH tPHL	Propagation Delay xCLK to xOx	CL = 50pF RL = 500Ω	2.0	5.2	2.0	6.2	1.5	3.7	—	—	ns
tPZH tPZL	Output Enable Time		1.5	5.5	1.5	6.2	1.5	4.4	—	—	ns
tPHZ tPLZ	Output Disable Time		1.5	5.0	1.5	5.7	1.5	3.6	—	—	ns
tsU	Set-up Time HIGH or LOW, xDx to xCLK		2.0	—	2.0	—	1.5	—	—	—	ns
tH	Hold Time HIGH or LOW, xDx to xCLK		1.5	—	1.5	—	0.0	—	—	—	ns
tw	xCLK Pulse Width HIGH or LOW		5.0	—	6.0	—	3.0 ⁽⁴⁾	—	—	—	ns
tsk(o)	Output Skew ⁽³⁾		—	0.5	—	0.5	—	0.5	—	—	ns

NOTES:

1. See test circuit and waveforms.
2. Minimum limits are guaranteed but not tested on Propagation Delays.
3. Skew between any two outputs of the same package switching in the same direction. This parameter is guaranteed by design.
4. This limit is guaranteed but not tested.

2542 tbl 09

TEST CIRCUITS AND WAVEFORMS

TEST CIRCUITS FOR ALL OUTPUTS

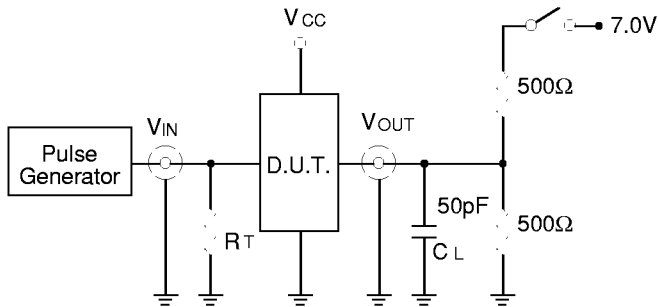

2542 drw 05

SWITCH POSITION

Test	Switch
Open Drain Disable Low Enable Low	Closed
All Other Tests	Open

DEFINITIONS:

CL = Load capacitance: includes jig and probe capacitance.
RT = Termination resistance: should be equal to ZOUT of the Pulse Generator.

2542 Ink 10

SET-UP, HOLD AND RELEASE TIMES

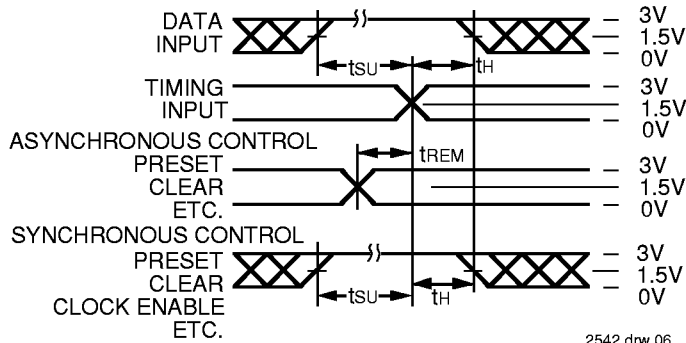

2542 drw 06

PULSE WIDTH

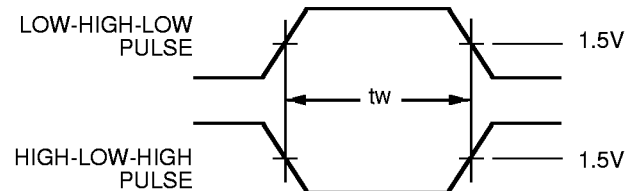

2542 drw 07

PROPAGATION DELAY

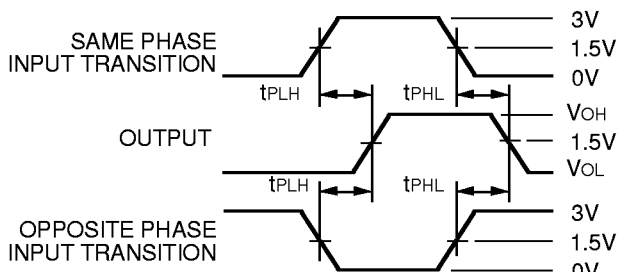

2542 drw 08

ENABLE AND DISABLE TIMES

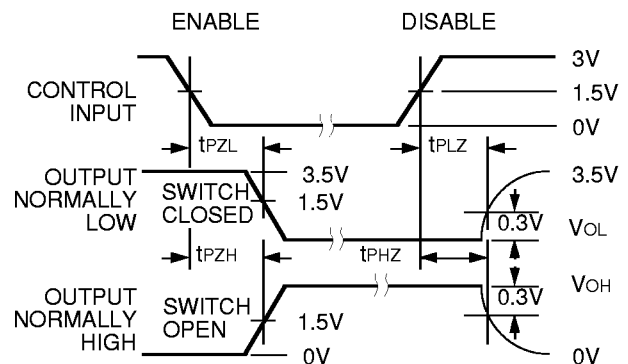

NOTES:

- Diagram shown for input Control Enable-LOW and input Control Disable-HIGH
- Pulse Generator for All Pulses: Rate $\leq 1.0\text{MHz}$; $t_f \leq 2.5\text{ns}$; $t_r \leq 2.5\text{ns}$

2542 drw 09

ORDERING INFORMATION

IDT	XX	FCT	XXXX	X	X	
	Temp. Range		Device Type	Package	Process	
						Blank B
						Commercial MIL-STD-883, Class B
						PV PA PF E
						Shrink Small Outline Package (SO48-1) Thin Shrink Small Outline Package (SO48-2) Thin Very Small Outline Package (SO48-3) CERPACK (E48-1)
						16374T 16374AT 16374CT 16374ET 162374T 162374AT 162374CT 162374ET
						Non-Inverting 16-Bit Register
						54 74
						-55°C to +125°C -40°C to +85°C

2542 drw 10