



4-Bit Bistable Latch With Q and \bar{Q}

ELECTRICALLY TESTED PER:
MIL-M-38510/31601

The 54LS75 is a 4-Bit D-Type Latch for use as temporary storage for binary information between processing limits and input/output or indicator units. Information present at the data (D) input is transferred to the Q output when the Enable is HIGH and the Q output will follow the data input as long as the Enable remains HIGH. When the Enable goes LOW, the information (that was present at the data input at the time the transition occurred) is retained at the Q output until the Enable is permitted to go HIGH.

LOGIC DIAGRAM

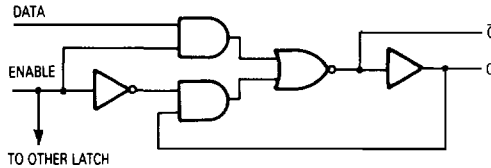

CONNECTION DIAGRAM

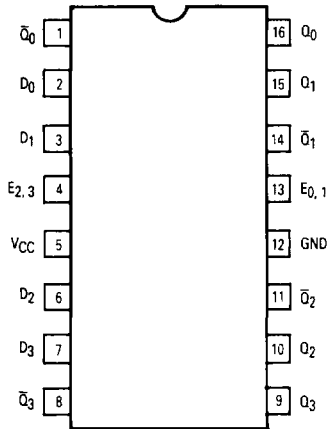

LOGIC SYMBOL

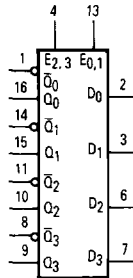

Pin Names	Loading (Note a)	
	HIGH	LOW
D ₁ -D ₄	0.5 U.L.	0.25 U.L.
E ₀ -E ₁	2.0 U.L.	1.0 U.L.
E ₂ -E ₃	2.0 U.L.	1.0 U.L.
Q ₁ -Q ₄	10 U.L.	5(2.5) U.L.
\bar{Q} ₁ - \bar{Q} ₄	10 U.L.	5(2.5) U.L.

NOTES:

- a. One Unit load (U.L.) = 40 μ A HIGH/1.6 mA LOW.
- b. The Output LOW drive factor is 2.5 U.L. for Military (54) and 5 U.L. for commercial (74) Temperature Ranges.

Military 54LS75



AVAILABLE AS:

- 1) JAN: JM38510/31601BXA
- 2) SMD: *
- 3) 883C: 54LS75/BXAJC

X = CASE OUTLINE AS FOLLOWS:

PACKAGE: CERDIP: E

CERFLAT: F

LCC: SEE 54LS375

*Call Factory for latest update

PIN ASSIGNMENTS

FUNCTION	DIL	FLATS	BURN-IN (CONDITION A)
\bar{Q} ₁	1	1	OPEN
D ₁	2	2	VCC
D ₂	3	3	VCC
E _n 3-4	4	4	VCC
VCC	5	5	VCC
D ₃	6	6	VCC
D ₄	7	7	VCC
\bar{Q} ₄	8	8	OPEN
Q ₄	9	9	VCC
Q ₃	10	10	VCC
\bar{Q} ₃	11	11	OPEN
GND	12	12	GND
E _n 1-2	13	13	VCC
\bar{Q} ₂	14	14	OPEN
Q ₂	15	15	VCC
Q ₁	16	16	VCC

BURN-IN CONDITIONS:

VCC = 5.0 V MIN/6.0 V MAX

TRUTH TABLE (Each Latch)

t _n	t _n + 1
D	Q
H	H
L	L

t_n = Bit time before enable negative-going transition

t_n + 1 = Bit time after enable negative-going transition

54LS75

AC TEST CIRCUIT

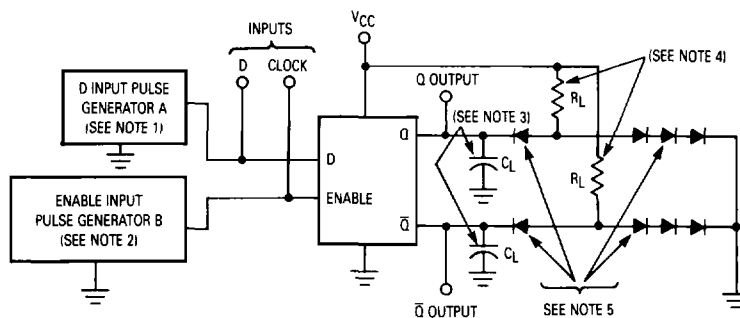

Switching Test Circuit and Waveforms

WAVEFORMS

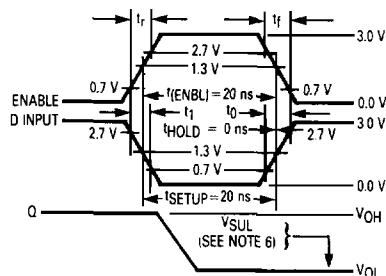
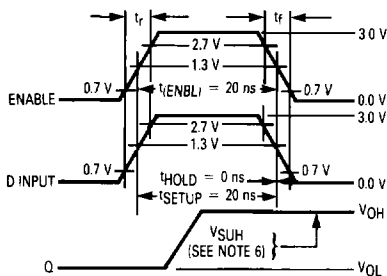

Setup and Hold Waveforms

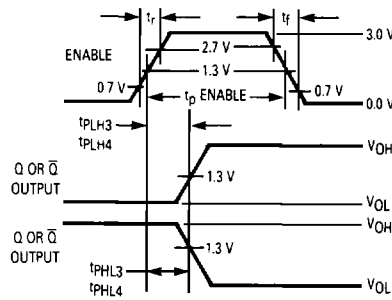
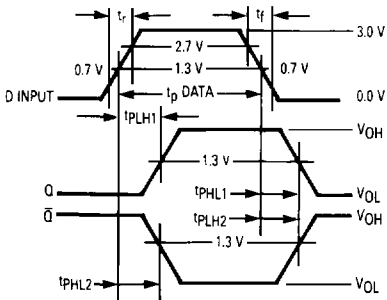

54LS75

Symbol	Parameter	Limits						Units	Test Condition (Unless Otherwise Specified)
		+ 25°C		+ 125°C		- 55°C			
		Subgroup 1		Subgroup 2		Subgroup 3			
		Min	Max	Min	Max	Min	Max		
V _{OH}	Logical "1" Output Voltage	2.5		2.5		2.5		V	V _{CC} = 4.5 V, I _{OH} = -0.4 mA, V _{IH} = 2.0 V or 0.7 V per truth table, Enable = (See Note 7).
V _{OL}	Logical "0" Output Voltage		0.4		0.4		0.4	V	V _{CC} = 4.5 V, I _{OL} = 4.0 mA, V _{IL} = 0.7 V or 2.0 V per truth table, Enable = (See Note 7).
V _{IC}	Input Clamping Voltage		-1.5					V	V _{CC} = 4.5 V, I _{IN} = -18 mA, other inputs are open.
I _{IH1}	Logical "1" Input Current (D inputs)		20		20		20	μA	V _{CC} = 5.5 V, V _{IH} = 2.7 V, other input is open.
I _{IHH1}	Logical "1" Input Current (E _N inputs)		80		80		80	μA	V _{CC} = 5.5 V, V _{IH} = GND, V _{IN(E_N)} = 2.7 V.
I _{IH2}	Logical "1" Input Current (D inputs)		100		100		100	μA	V _{CC} = 5.5 V, V _{IH} = 5.5 V, V _{IN(E_N)} = GND.
I _{IHH2}	Logical "1" Input Current (E _N inputs)		400		400		400	μA	V _{CC} = 5.5 V, V _{IH} = GND, V _{IN(E_N)} = 5.5 V.
I _{IL1}	Logical "0" Input Current (D inputs)	-0.16	-0.4	-0.16	-0.4	-0.16	-0.4	mA	V _{CC} = 5.5 V, V _{IL} = 0.4 V, V _{IN(E_N)} = 4.5 V.
I _{IL2}	Logical "0" Input Current (E _N inputs)	-0.64	-1.6	-0.64	-1.6	-0.64	-1.6	mA	V _{CC} = 5.5 V, V _{IN(E_N)} = 0.4 V, other input = 4.5 V.
I _{OS}	Output Short Circuit Current	-15	-100	-15	-100	-15	-100	mA	V _{CC} = 5.5 V, V _{IN(E_N)} = 4.5 V, other inputs = 4.5 V GND.
I _{CC}	Power Supply Current		12		12		12	mA	V _{CC} = 5.5 V, V _{IN} = GND (all inputs).
V _{IH}	Logical "1" Input Voltage	2.0		2.0		2.0		V	V _{CC} = 4.5 V.
V _{IL}	Logical "0" Input Voltage		0.7		0.7		0.7	V	V _{CC} = 4.5 V.
	Functional Tests	Subgroup 7		Subgroup 8A		Subgroup 8B			per Truth Table with V _{CC} = 5.0 V, V _{INL} = 0.4 V, and V _{INH} = 2.5 V.

54LS75

Symbol	Parameter	Limits						Units	Test Condition (Unless Otherwise Specified)
		+ 25°C		+ 125°C		- 55°C			
		Subgroup 9		Subgroup 10		Subgroup 11			
		Min	Max	Min	Max	Min	Max		
t _{PHL1} t _{PHL1}	Propagation Delay /Data-Output Data to Q	3.0	22 17	3.0	29 24	3.0	29 24	ns ns	V _{CC} = 5.0 V, C _L = 50 pF, R _L = 2.0 kΩ ± 5.0%. V _{CC} = 5.0 V, C _L = 15 pF, R _L = 2.0 kΩ ± 5.0%.
t _{PLH1} t _{PLH1}	Propagation Delay /Data-Output Data to Q	3.0	32 27	3.0	42 37	3.0	42 37	ns ns	V _{CC} = 5.0 V, C _L = 50 pF, R _L = 2.0 kΩ ± 5.0%. V _{CC} = 5.0 V, C _L = 15 pF, R _L = 2.0 kΩ ± 5.0%.
t _{PHL2} t _{PHL2}	Propagation Delay /Data-Output Data to \bar{Q}	3.0	20 15	3.0	26 21	3.0	26 21	ns ns	V _{CC} = 5.0 V, C _L = 50 pF, R _L = 2.0 kΩ ± 5.0%. V _{CC} = 5.0 V, C _L = 15 pF, R _L = 2.0 kΩ ± 5.0%.
t _{PLH2} t _{PLH2}	Propagation Delay /Data-Output Data to \bar{Q}	3.0	25 20	3.0	32 27	3.0	32 27	ns ns	V _{CC} = 5.0 V, C _L = 50 pF, R _L = 2.0 kΩ ± 5.0%. V _{CC} = 5.0 V, C _L = 15 pF, R _L = 2.0 kΩ ± 5.0%.
t _{PHL3} t _{PHL3}	Propagation Delay /Data-Output E _N to Q	3.0	30 25	3.0	39 34	3.0	39 34	ns ns	V _{CC} = 5.0 V, C _L = 50 pF, R _L = 2.0 kΩ ± 5.0%. V _{CC} = 5.0 V, C _L = 15 pF, R _L = 2.0 kΩ ± 5.0%.
t _{PLH3} t _{PLH3}	Propagation Delay /Data-Output E _N to Q	3.0	32 27	3.0	42 37	3.0	42 37	ns ns	V _{CC} = 5.0 V, C _L = 50 pF, R _L = 2.0 kΩ ± 5.0%. V _{CC} = 5.0 V, C _L = 15 pF, R _L = 2.0 kΩ ± 5.0%.
t _{PHL4} t _{PHL4}	Propagation Delay /Data-Output E _N to \bar{Q}	3.0	20 15	3.0	26 21	3.0	26 21	ns ns	V _{CC} = 5.0 V, C _L = 50 pF, R _L = 2.0 kΩ ± 5.0%. V _{CC} = 5.0 V, C _L = 15 pF, R _L = 2.0 kΩ ± 5.0%.
t _{PLH4} t _{PLH4}	Propagation Delay /Data-Output E _N to \bar{Q}	3.0	35 30	3.0	46 44	3.0	46 44	ns ns	V _{CC} = 5.0 V, C _L = 50 pF, R _L = 2.0 kΩ ± 5.0%. V _{CC} = 5.0 V, C _L = 15 pF, R _L = 2.0 kΩ ± 5.0%.
VS _{UH}	Logical "1" Setup Voltage	2.5		2.5		2.5		V	V _{CC} = 5.0 V, C _L = 50 pF, R _L = 2.0 kΩ ± 5.0%.
VS _{UL}	Logical "0" Setup Voltage		0.4		0.4		0.4	V	V _{CC} = 5.0 V, C _L = 50 pF, R _L = 2.0 kΩ ± 5.0%.

NOTES:

1. The D input pulse generator has the following characteristics:
V_{GEN} = 3.0 V, t_r ≤ 15 ns, t_f ≤ 6.0 ns, t_p = 30 ns and Z_{OUT} = 50 Ω except when measuring V_{SETUP}.
2. The enable pulse generator is identical to the D input pulse generator.
3. C_L = 15 pF ± 10%, which includes probe and jig capacitance.
4. R_L = 2.0 kΩ ± 5.0%.
5. All diodes are 1N3064 or equivalent.
6. V_{SETUP} is to be measured 500 ns minimum after input transition to assure that the device has latched with minimum setup and maximum hold conditions applied to inputs.
7. Apply 0 V/3.0 V - 5.0 V/0 V momentary pulse 500 ns minimum prior to measurement.
8. For all t_{PLH} and VS_{UH} tests, preset output into the ZERO state prior to making test.
9. For all t_{PHL} and VS_{UL} tests, preset output into ONE state prior to making test.
10. The limits specified for C_L = 15 pF are guaranteed but not tested.