

Quad Precision Op Amp (LT1014) Dual Precision Op Amp (LT1013)

FEATURES

- Single Supply Operation
 - Input Voltage Range Extends to Ground
 - Output Swings to Ground while Sinking Current
- Pin Compatible to 1458 and 324 with Precision Specs
- *Guaranteed* Offset Voltage 150 μ V Max.
- *Guaranteed* Low Drift 2 μ V/ $^{\circ}$ C Max.
- *Guaranteed* Offset Current 0.8nA Max.
- *Guaranteed* High Gain
 - 5mA Load Current 1.5 Million Min.
 - 17mA Load Current 0.8 Million Min.
- *Guaranteed* Low Supply Current 500 μ A Max.
- Low Voltage Noise, 0.1Hz to 10Hz 0.55 μ Vp-p
- Low Current Noise—Better than OP-07, 0.07 pA/ \sqrt Hz

APPLICATIONS

- Battery-Powered Precision Instrumentation
 - Strain Gauge Signal Conditioners
 - Thermocouple Amplifiers
 - Instrumentation Amplifiers
- 4mA–20mA Current Loop Transmitters
- Multiple Limit Threshold Detection
- Active Filters
- Multiple Gain Blocks

DESCRIPTION

The LT1014 is the first precision quad operational amplifier which directly upgrades designs in the industry standard 14-pin DIP LM324/LM348/OP-11/4156 pin configuration. It is no longer necessary to compromise specifications, while saving board space and cost, as compared to single operational amplifiers.

The LT1014's low offset voltage of 50 μ V, drift of 0.3 μ V/ $^{\circ}$ C, offset current of 0.15nA, gain of 8 million, common-mode rejection of 117dB, and power supply rejection of 120dB qualify it as four truly precision operational amplifiers. Particularly important is the low offset voltage, since no offset null terminals are provided in the quad configuration. Although supply current is only 350 μ A per amplifier, a new output stage design sources and sinks in excess of 20mA of load current, while retaining high voltage gain.

Similarly, the LT1013 is the first precision dual op amp in the 8-pin industry standard configuration, upgrading the performance of such popular devices as the MC1458/1558, LM158 and OP-221. The LT1013's specifications are similar to (even somewhat better than) the LT1014's.

Both the LT1013 and LT1014 can be operated off a single 5V power supply: input common-mode range includes ground; the output can also swing to within a few millivolts of ground. Crossover distortion, so apparent on previous single-supply designs, is eliminated. A full set of specifications is provided with \pm 15V and single 5V supplies.

3 Channel Thermocouple Thermometer

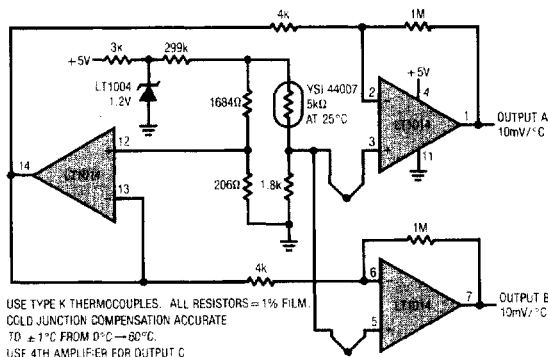

LT1014 Distribution of Offset Voltage

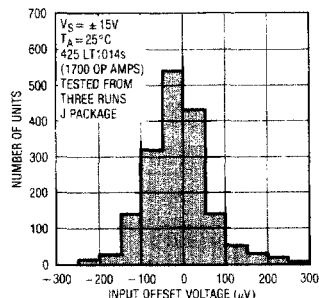

LT1013/LT1014

ABSOLUTE MAXIMUM RATINGS

Supply Voltage	$\pm 22V$
Differential Input Voltage	$\pm 30V$
Input Voltage	Equal to Positive Supply Voltage
.....	5V Below Negative Supply Voltage
Output Short Circuit Duration	Indefinite
Storage Temperature Range	
All Grades	$-85^{\circ}C$ to $150^{\circ}C$

Lead Temperature (Soldering, 10 sec.)	$300^{\circ}C$
Operating Temperature Range	
LT1013AM/LT1013M/	
LT1014AM/LT1014M	$-55^{\circ}C$ to $125^{\circ}C$
LT1013AC/LT1013C/LT1013D	
LT1014AC/LT1014C/LT1014D	$0^{\circ}C$ to $70^{\circ}C$
LT1013I/LT1014I	$-40^{\circ}C$ to $85^{\circ}C$

PACKAGE/ORDER INFORMATION

<p>TOP VIEW</p> <p>OUTPUT A 1, 2, 3, 4, 5, 6, 7, 8 OUTPUT B</p> <p>-IN A -IN B</p> <p>V- (CASE) H PACKAGE B LEAD TO 6 METAL CAN</p>	ORDER PART NUMBER	<p>TOP VIEW</p> <p>OUTPUT A 1, 2, 3, 4, 5, 6, 7, 8 OUTPUT B</p> <p>-IN A -IN B</p> <p>V+ V-</p> <p>J PACKAGE S LEAD CERAMIC DIP N PACKAGE B LEAD PLASTIC DIP</p>	<p>TOP VIEW</p> <p>OUTPUT A 1, 2, 3, 4, 5, 6, 7, 8 OUTPUT B</p> <p>-IN A -IN B</p> <p>V+ V-</p> <p>+IN A +IN B</p> <p>OUTPUT D OUTPUT C</p> <p>-IN D -IN C</p> <p>J PACKAGE 14-LEAD CERAMIC DIP N PACKAGE 14-LEAD PLASTIC DIP</p>	ORDER PART NUMBER
	<p>LT1013AMH</p> <p>LT1013MH</p> <p>LT1013ACH</p> <p>LT1013CH</p>			<p>LT1013AMJ8</p> <p>LT1013MJ8</p> <p>LT1013ACJ8</p> <p>LT1013CJ8</p> <p>LT1013CN8</p> <p>LT1013DN8</p> <p>LT1013IN8</p>
<p>TOP VIEW</p> <p>+IN A 1, 2, 3, 4, 5, 6, 7, 8 -IN A</p> <p>V- +IN B -IN B</p> <p>SO PACKAGE B LEAD PLASTIC SOIC</p> <p>NOTE: THIS PIN CONFIGURATION DIFFERS FROM THE STANDARD 8-PIN QUAD IN-LINE CONFIGURATION.</p>	ORDER PART NUMBER	<p>TOP VIEW</p> <p>OUTPUT A 1, 2, 3, 4, 5, 6, 7, 8 OUTPUT B</p> <p>-IN A -IN B</p> <p>V+ V-</p> <p>+IN A +IN B</p> <p>OUTPUT D OUTPUT C</p> <p>-IN D -IN C</p> <p>NC 15</p> <p>S PACKAGE 16-LEAD PLASTIC SOI</p>	ORDER PART NUMBER	
	<p>LT1013DS8</p> <p>LT1013IS8</p>		<p>LT1014DS</p> <p>LT1014IS</p>	
	PART MARKING		PART MARKING	
	1013 1013I		LT1014DS LT1014IS	

ELECTRICAL CHARACTERISTICS $V_S = \pm 15V$, $V_{CM} = 0V$, $T_A = 25^{\circ}C$ unless otherwise noted

SYMBOL	PARAMETER	CONDITIONS	LT1013AM/AC LT1014AM/AC			LT1013C/D/I/M LT1014C/D/I/M			UNITS
			MIN	TYP	MAX	MIN	TYP	MAX	
V_{OS}	Input Offset Voltage	LT1013	—	40	150	—	60	300	μV
		LT1014	—	50	180	—	60	300	μV
		LT1013D/I, LT1014D/I	—	—	—	—	200	800	μV
	Long Term Input Offset Voltage Stability		—	0.4	—	—	0.5	—	$\mu V/Mo.$
I_{OS}	Input Offset Current		—	0.15	0.8	—	0.2	1.5	nA
I_B	Input Bias Current		—	12	20	—	15	30	nA
e_n	Input Noise Voltage	0.1Hz to 10Hz	—	0.55	—	—	0.55	—	$\mu Vp-p$
e_n	Input Noise Voltage Density	$f_0 = 10Hz$	—	24	—	—	24	—	nV/\sqrt{Hz}
		$f_0 = 1000Hz$	—	22	—	—	22	—	nV/\sqrt{Hz}
i_n	Input Noise Current Density	$f_0 = 10Hz$	—	0.07	—	—	0.07	—	pA/\sqrt{Hz}
	Input Resistance—Differential Common-Mode	(Note 1)	100	400	—	70	300	—	M Ω
			—	5	—	—	4	—	G Ω

ELECTRICAL CHARACTERISTICS

$V_S = \pm 15V$, $V_{CM} = 0V$, $T_A = 25^\circ C$ unless otherwise noted

SYMBOL	PARAMETER	CONDITIONS	LT1013AM/AC LT1014AM/AC			LT1013C/D/I/M LT1014C/D/I/M			UNITS
			MIN	TYP	MAX	MIN	TYP	MAX	
A_{VOL}	Large Signal Voltage Gain	$V_D = \pm 10V$, $R_L = 2k$ $V_D = \pm 10V$, $R_L = 600\Omega$	1.5 0.8	8.0 2.5	—	1.2 0.5	7.0 2.0	—	$V/\mu V$ $V/\mu V$
	Input Voltage Range		+13.5 -15.0	+13.8 -15.3	—	+13.5 -15.0	+13.8 -15.3	—	V V
CMRR	Common-Mode Rejection Ratio	$V_{CM} = +13.5V$, $-15.0V$	100	117	—	97	114	—	dB
PSRR	Power Supply Rejection Ratio	$V_S = \pm 2V$ to $\pm 18V$	103	120	—	100	117	—	dB
	Channel Separation	$V_D = \pm 10V$, $R_L = 2k$	123	140	—	120	137	—	dB
V_{OUT}	Output Voltage Swing	$R_L = 2k$	± 13	± 14	—	± 12.5	± 14	—	V
	Slew Rate		0.2	0.4	—	0.2	0.4	—	$V/\mu s$
I_S	Supply Current	Per Amplifier	—	0.35	0.50	—	0.35	0.55	mA

Note 1: This parameter is guaranteed by design and is not tested. Typical parameters are defined as the 60% yield of parameter distributions of individual amplifiers; i.e., out of 100 LT1014s (or 100 LT1013s) typically 240 op amps (or 120) will be better than the indicated specification.

ELECTRICAL CHARACTERISTICS

$V_S^+ = +5V$, $V_S^- = 0V$, $V_{OUT} = 1.4V$, $V_{CM} = 0V$, $T_A = 25^\circ C$ unless otherwise noted

SYMBOL	PARAMETER	CONDITIONS	LT1013AM/AC LT1014AM/AC			LT1013C/D/I/M LT1014C/D/I/M			UNITS
			MIN	TYP	MAX	MIN	TYP	MAX	
V_{OS}	Input Offset Voltage	LT1013	—	60	250	—	90	450	μV
		LT1014	—	70	280	—	90	450	μV
		LT1013D/I, LT1014D/I	—	—	—	—	250	950	μV
I_{OS}	Input Offset Current		—	0.2	1.3	—	0.3	2.0	nA
I_B	Input Bias Current		—	15	35	—	18	50	nA
A_{VOL}	Large Signal Voltage Gain	$V_D = 5mV$ to $4V$, $R_L = 500\Omega$	—	1.0	—	—	1.0	—	$V/\mu V$
	Input Voltage Range		+3.5 0	+3.8 -0.3	—	+3.5 0	+3.8 -0.3	—	V V
V_{OUT}	Output Voltage Swing	Output Low, No Load	—	15	25	—	15	25	mV
		Output Low, 600Ω to Ground	—	5	10	—	5	10	mV
		Output Low, $I_{SINK} = 1mA$	—	220	350	—	220	350	mV
		Output High, No Load	4.0	4.4	—	4.0	4.4	—	V
		Output High, 600Ω to Ground	3.4	4.0	—	3.4	4.0	—	V
I_S	Supply Current	Per Amplifier	—	0.31	0.45	—	0.32	0.50	mA

ELECTRICAL CHARACTERISTICS $V_S = \pm 15V, V_{CM} = 0V, -55^\circ C \leq T_A \leq 125^\circ C$ unless otherwise noted

SYMBOL	PARAMETER	CONDITIONS	LT1013AM			LT1014AM			LT1013M/LT1014M			UNITS	
			MIN	TYP	MAX	MIN	TYP	MAX	MIN	TYP	MAX		
V_{OS}	Input Offset Voltage	$V_S = +5V, 0V; V_O = +1.4V$ $-55^\circ C \leq T_A \leq 100^\circ C$ $V_{CM} = 0.1V, T_A = 125^\circ C$ $V_{CM} = 0V, T_A = 125^\circ C$	●	—	80	300	—	90	350	—	110	550	μV
			●	—	80	450	—	90	480	—	100	750	μV
			●	—	120	450	—	150	480	—	200	750	μV
			●	—	250	900	—	300	960	—	400	1500	μV
	Input Offset Voltage Drift	(Note 2)	●	—	0.4	2.0	—	0.4	2.0	—	0.5	2.5	$\mu V/^\circ C$
I_{OS}	Input Offset Current	$V_S = +5V, 0V; V_O = +1.4V$	●	—	0.3	2.5	—	0.3	2.8	—	0.4	5.0	nA
			●	—	0.6	6.0	—	0.7	7.0	—	0.9	10.0	nA
I_B	Input Bias Current	$V_S = +5V, 0V; V_O = +1.4V$	●	—	15	30	—	15	30	—	18	45	nA
			●	—	20	80	—	25	90	—	28	120	nA
A_{VOL}	Large Signal Voltage Gain	$V_O = \pm 10V, R_L = 2k$	●	0.5	2.0	—	0.4	2.0	—	0.25	2.0	—	$V/\mu V$
CMRR	Common-Mode Rejection	$V_{CM} = +13.0V, -14.9V$	●	97	114	—	96	114	—	94	113	—	dB
PSRR	Power Supply Rejection Ratio	$V_S = \pm 2V$ to $\pm 18V$	●	100	117	—	100	117	—	97	116	—	dB
V_{OUT}	Output Voltage Swing	$R_L = 2k$ $V_S = +5V, 0V;$ $R_L = 600\Omega$ to Ground Output Low Output High	●	± 12	± 13.8	—	± 12	± 13.8	—	± 11.5	± 13.8	—	V
			●	—	6	15	—	6	15	—	6	18	mV
			●	3.2	3.8	—	3.2	3.8	—	3.1	3.8	—	V
			●	—	0.38	0.60	—	0.38	0.60	—	0.38	0.7	mA
I_S	Supply Current Per Amplifier	$V_S = +5V, 0V; V_O = +1.4V$	●	—	0.34	0.55	—	0.34	0.55	—	0.34	0.65	mA
			●	—	0.34	0.55	—	0.34	0.55	—	0.34	0.65	mA

ELECTRICAL CHARACTERISTICS

$V_S = \pm 15V, V_{CM} = 0V, -40^\circ C \leq T_A \leq 85^\circ C$ for LT1013I, LT1014I, $0^\circ C \leq T_A \leq 70^\circ C$ for LT1013C, LT1013D, LT1014C, LT1014D unless otherwise noted

SYMBOL	PARAMETER	CONDITIONS	LT1013AC			LT1014AC			LT1013C/D/I LT1014C/D/I			UNITS	
			MIN	TYP	MAX	MIN	TYP	MAX	MIN	TYP	MAX		
V_{OS}	Input Offset Voltage	LT1013D/I, LT1014D/I $V_S = +5V, 0V; V_O = 1.4V$ LT1013D/I, LT1014D/I $V_S = +5V, 0V; V_O = 1.4V$	●	—	55	240	—	65	270	—	80	400	μV
			●	—	—	—	—	—	—	—	230	1000	μV
			●	—	75	350	—	85	380	—	110	570	μV
			●	—	—	—	—	—	—	—	—	280	1200
	Average Input Offset Voltage Drift	(Note 2) LT1013D/I, LT1014D/I	●	—	0.3	2.0	—	0.3	2.0	—	0.4	2.5	$\mu V/^\circ C$
I_{OS}	Input Offset Current	$V_S = +5V, 0V, V_O = 1.4V$	●	—	0.2	1.5	—	0.2	1.7	—	0.3	2.8	nA
			●	—	0.4	3.5	—	0.4	4.0	—	0.5	6.0	nA
I_B	Input Bias Current	$V_S = +5V, 0V; V_O = 1.4V$	●	—	13	25	—	13	25	—	16	38	nA
			●	—	18	55	—	20	60	—	24	90	nA
A_{VOL}	Large Signal Voltage Gain	$V_O = \pm 10V, R_L = 2k$	●	1.0	5.0	—	1.0	5.0	—	0.7	4.0	—	$V/\mu V$
CMRR	Common-Mode Rejection Ratio	$V_{CM} = +13.0V, -15.0V$	●	98	116	—	98	116	—	94	113	—	dB
PSRR	Power Supply Rejection Ratio	$V_S = \pm 2V$ to $\pm 18V$	●	101	119	—	101	119	—	97	116	—	dB
V_{OUT}	Output Voltage Swing	$R_L = 2k$ $V_S = +5V, 0V, R_L = 600\Omega$ Output Low Output High	●	± 12.5	± 13.9	—	± 12.5	± 13.9	—	± 12.0	± 13.9	—	V
			●	—	6	13	—	6	13	—	6	13	mV
			●	3.3	3.9	—	3.3	3.9	—	3.2	3.9	—	V
			●	—	0.36	0.55	—	0.36	0.55	—	0.37	0.60	mA
I_S	Supply Current per Amplifier	$V_S = +5V, 0V; V_O = 1.4V$	●	—	0.32	0.50	—	0.32	0.50	—	0.34	0.55	mA
			●	—	0.32	0.50	—	0.32	0.50	—	0.34	0.55	mA

Note 2: This parameter is not 100% tested.

The ● denotes the specifications which apply over the full operating temperature range.

TYPICAL PERFORMANCE CHARACTERISTICS

Offset Voltage Drift with Temperature of Representative Units

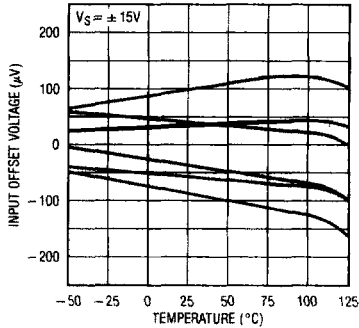

Offset Voltage vs Balanced Source Resistance

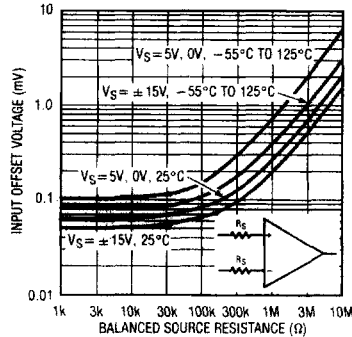

Warm-Up Drift

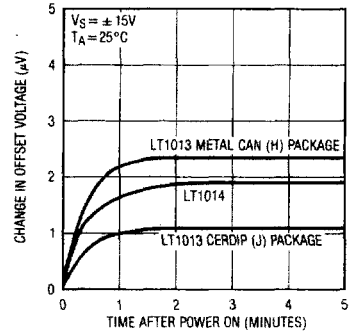

2

Common-Mode Rejection Ratio vs Frequency

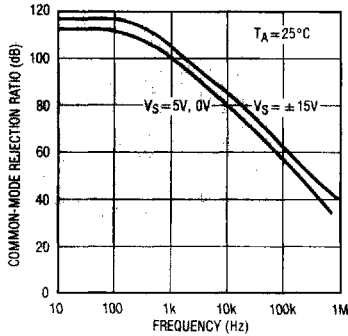

Power Supply Rejection Ratio vs Frequency

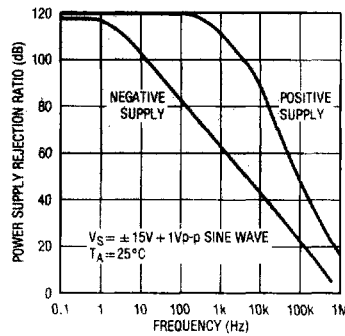

0.1Hz to 10Hz Noise

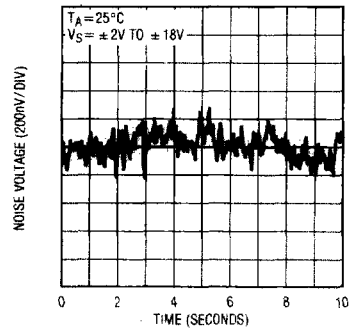

Noise Spectrum

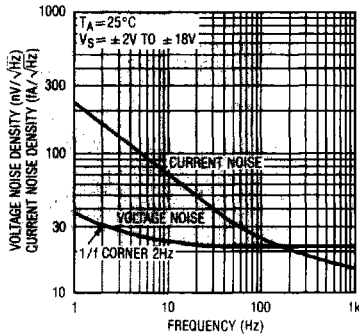

10Hz Voltage Noise Distribution

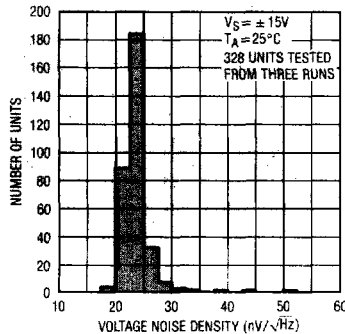

Supply Current vs Temperature

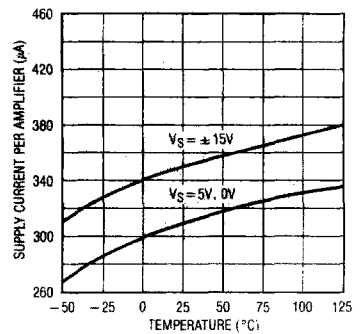

TYPICAL PERFORMANCE CHARACTERISTICS

Input Bias Current vs Common-Mode Voltage

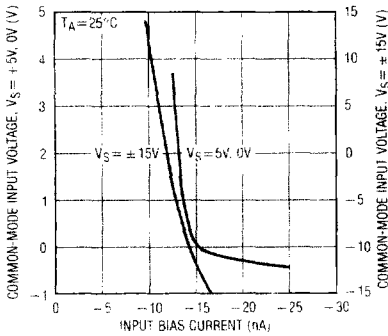

Input Offset Current vs Temperature

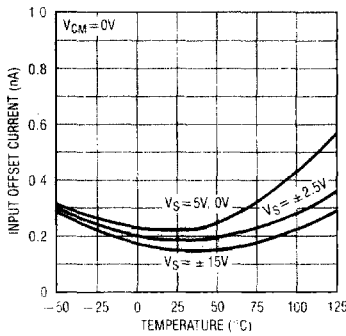

Input Bias Current vs Temperature

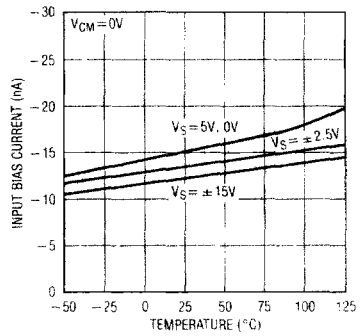

Output Saturation vs Sink Current vs Temperature

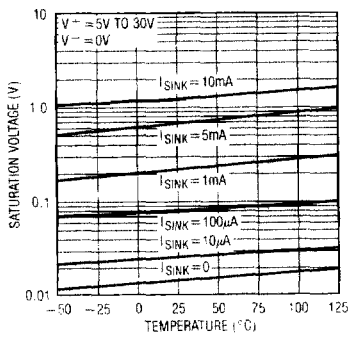

Small Signal Transient Response, V_S = ±15V

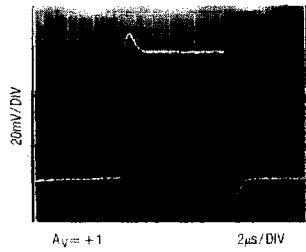

Large Signal Transient Response, V_S = ±15V

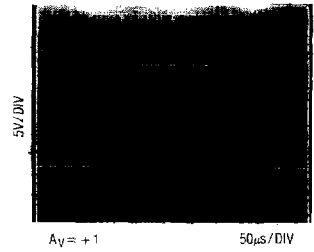

Small Signal Transient Response, V_S = 5V, 0V

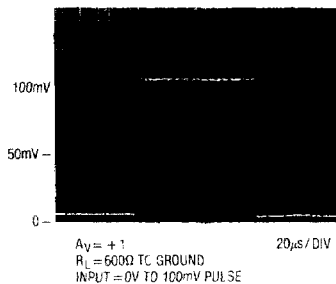

Large Signal Transient Response, V_S = 5V, 0V

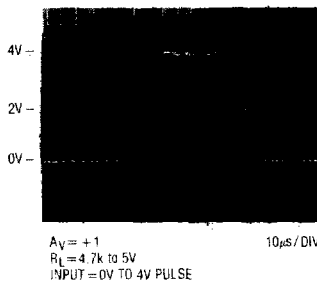

Large Signal Transient Response, V_S = 5V, 0V

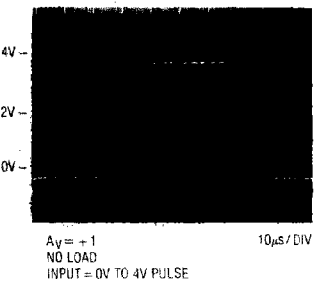

TYPICAL PERFORMANCE CHARACTERISTICS

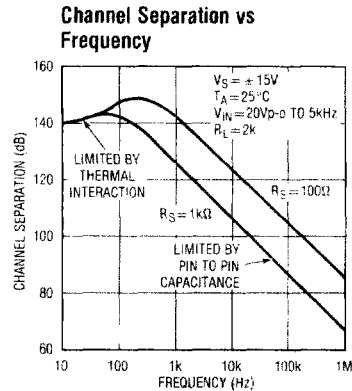
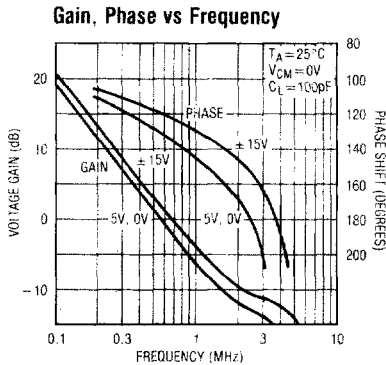
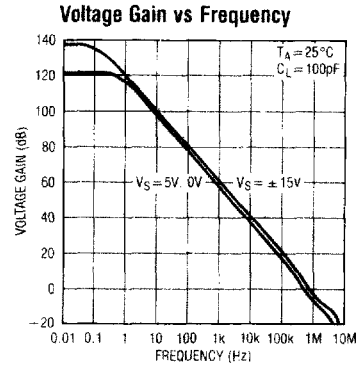
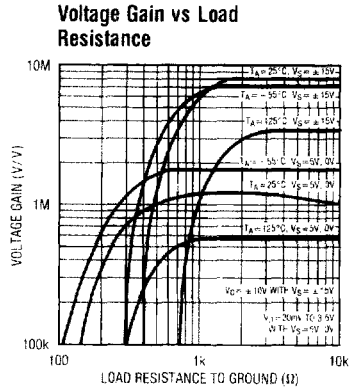
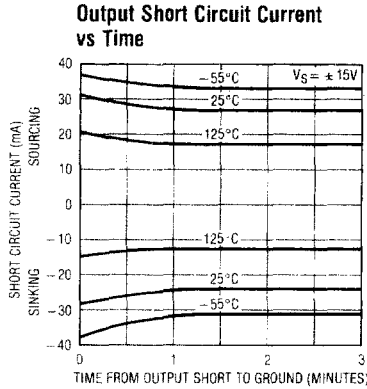

APPLICATIONS INFORMATION

Single Supply Operation

The LT1013/1014 are fully specified for single supply operation, i.e., when the negative supply is 0V. Input common-mode range includes ground; the output swings within a few millivolts of ground. Single supply operation, however, can create special difficulties, both at the input and at the output. The LT1013/LT1014 have specific circuitry which addresses these problems.

At the input, the driving signal can fall below 0V—inadvertently or on a transient basis. If the input is more than

a few hundred millivolts below ground, two distinct problems can occur on previous single supply designs, such as the LM124, LM158, OP-20, OP-21, OP-220, OP-221, OP-420:

a) When the input is more than a diode drop below ground, unlimited current will flow from the substrate (V^- terminal) to the input. This can destroy the unit. On the LT1013/1014, the 400 Ω resistors, in series with the input (see schematic diagram), protect the devices even when the input is 5V below ground.

APPLICATIONS INFORMATION

(b) When the input is more than 400mV below ground (at 25°C), the input stage saturates (transistors Q3 and Q4) and phase reversal occurs at the output. This can cause lock-up in servo systems. Due to a unique phase reversal protection circuitry (Q21, Q22, Q27, Q28), the LT1013/1014's outputs do not reverse, as illustrated below, even when the inputs are at $-1.5V$.

There is one circumstance, however, under which the phase reversal protection circuitry does not function: when the other op amp on the LT1013, or one specific amplifier of the other three on the LT1014, is driven hard into negative saturation at the output.

- Phase reversal protection does not work on amplifier:
- A when D's output is in negative saturation. B's and C's outputs have no effect.
 - B when C's output is in negative saturation. A's and D's outputs have no effect.
 - C when B's output is in negative saturation. A's and D's outputs have no effect.
 - D when A's output is in negative saturation. B's and C's outputs have no effect.

At the output, the aforementioned single supply designs either cannot swing to within 600mV of ground (OP-20) or cannot sink more than a few microamperes while swinging to ground (LM124, LM158). The LT1013/1014's all-NPN output stage maintains its low output resistance and high gain characteristics until the output is saturated.

In dual supply operations, the output stage is crossover distortion-free.

Comparator Applications

The single supply operation of the LT1013/1014 lends itself to its use as a precision comparator with TTL compatible output:

In systems using both op amps and comparators, the LT1013/1014 can perform multiple duties; for example, on the LT1014, two of devices can be used as op amps and the other two as comparators.

Voltage Follower with Input Exceeding the Negative Common-Mode Range

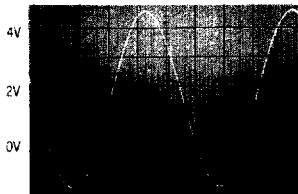

6Vp-p INPUT, $-1.5V$ TO $4.5V$

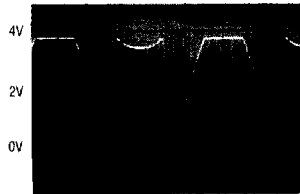

LM324 LM358, OP-20
EXHIBIT OUTPUT PHASE
REVERSAL

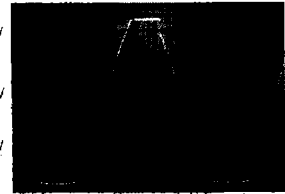

LT1013/LT1014
NO PHASE REVERSAL

Comparator Rise Response Time 10mV, 5mV, 2mV Overdrives

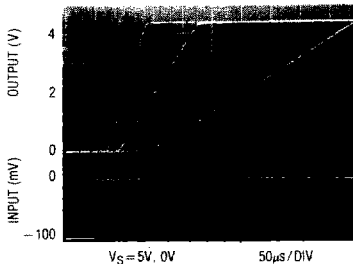

$V_S = 5V, 0V$ 50 μ s/DIV

Comparator Fall Response Time to 10mV, 5mV, 2mV Overdrives

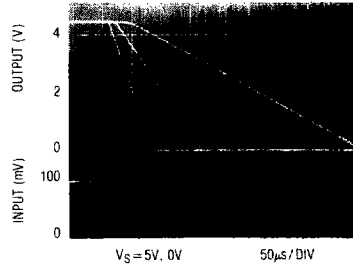

$V_S = 5V, 0V$ 50 μ s/DIV

APPLICATIONS INFORMATION

Low Supply Operation

The minimum supply voltage for proper operation of the LT1013/1014 is 3.4V (three Ni-Cad batteries). Typical supply current at this voltage is 290μA, therefore power dissipation is only one milliwatt per amplifier.

Noise Testing

For application information on noise testing and calculations, please see the LT1007 or LT1008 data sheet.

Test Circuit for Offset Voltage and Offset Drift with Temperature

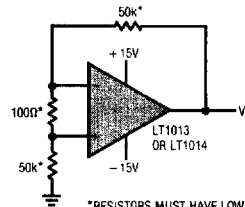

*RESISTORS MUST HAVE LOW THERMOELECTRIC POTENTIAL.
 **THIS CIRCUIT IS ALSO USED AS THE BURN-IN CONFIGURATION, WITH SUPPLY VOLTAGES INCREASED TO ±20V.
 $V_O = 1000V_{OS}$

2

TYPICAL APPLICATIONS

50MHz Thermal rms to DC Converter

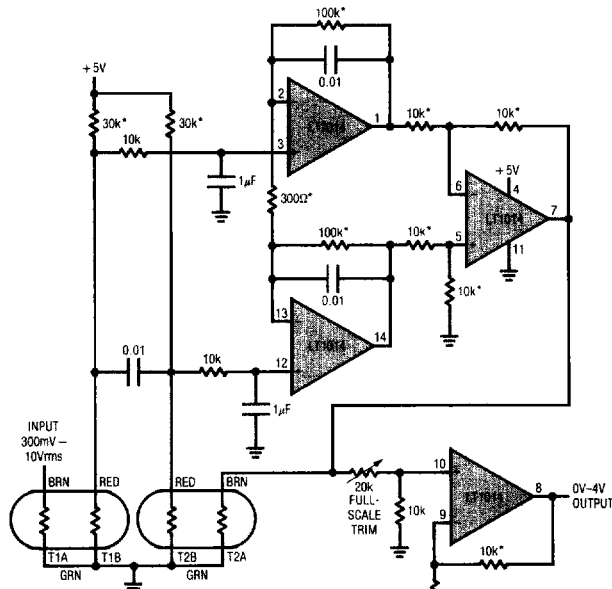

2% ACCURACY, DC-50MHz.
 100:1 CREST FACTOR CAPABILITY.
 *0.1% RESISTOR.
 T1-T2 = YELLOW SPRINGS INST. CO. THERMISTOR COMPOSITE #44018.
 ENCLOSE T1 AND T2 IN STYROFOAM.
 7.5mW DISSIPATION.

5V Single Supply Dual Instrumentation Amplifier

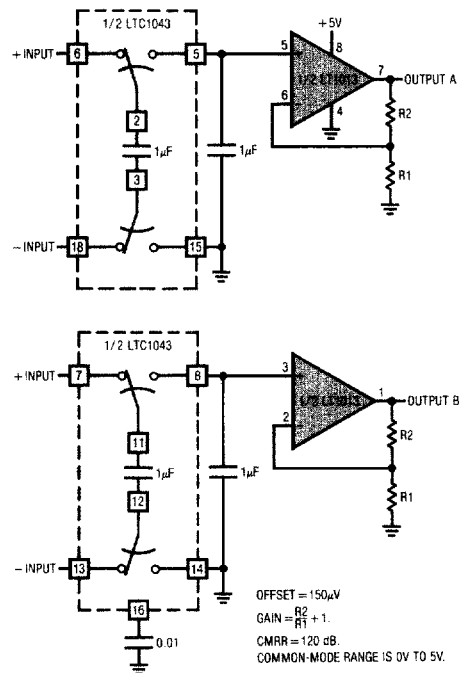

OFFSET = 150μV
 GAIN = $\frac{R_2}{R_1} + 1$.
 CMRR = 120 dB.
 COMMON-MODE RANGE IS 0V TO 5V.

TYPICAL APPLICATIONS

Hot Wire Anemometer

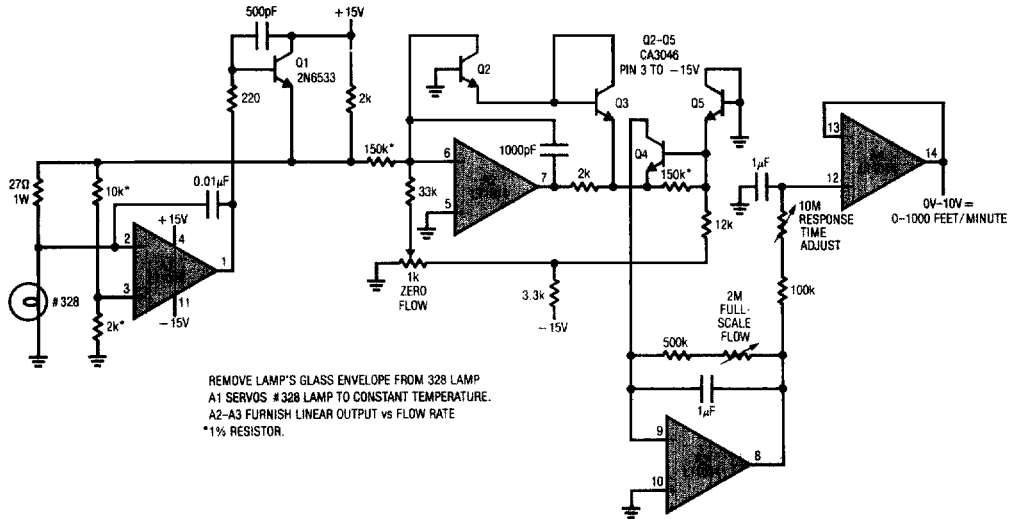

Liquid Flowmeter

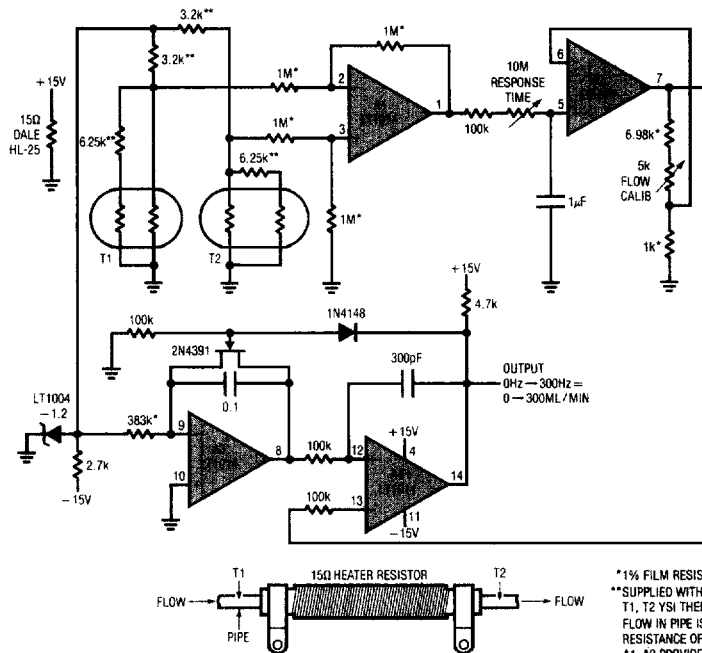

TYPICAL APPLICATIONS

5V Powered Precision Instrumentation Amplifier

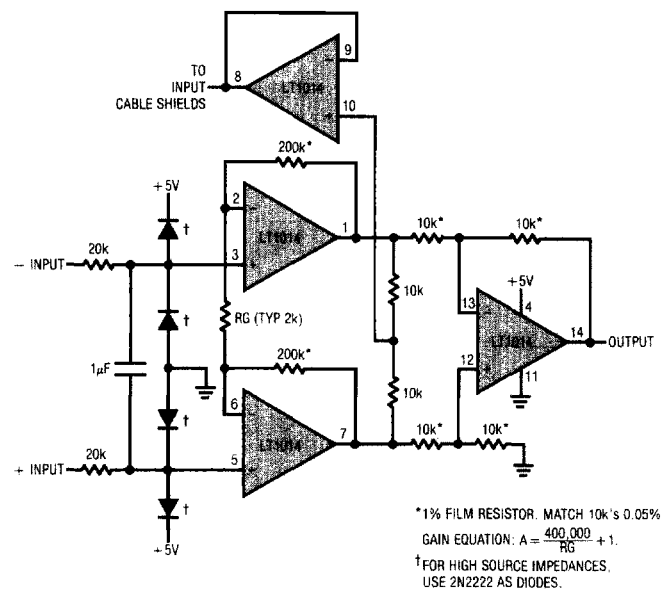

2

9V Battery Powered Strain Gage Signal Conditioner

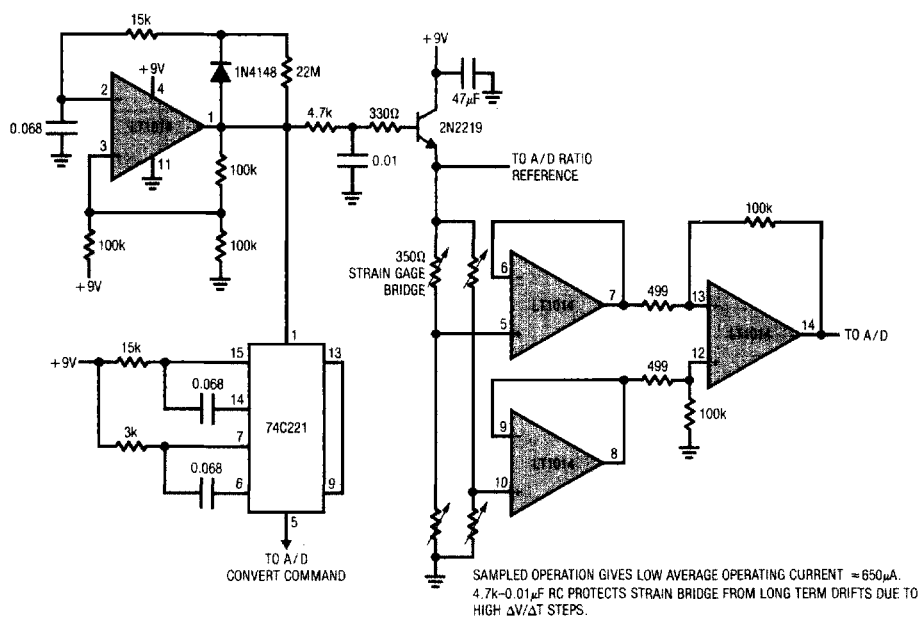

TYPICAL APPLICATIONS

**5V Powered Motor Speed Controller
No Tachometer Required**

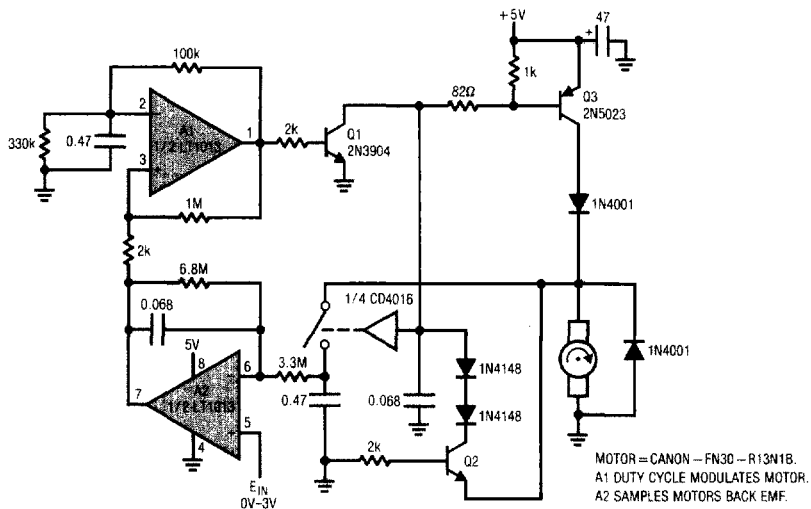

5V Powered EEPROM Pulse Generator

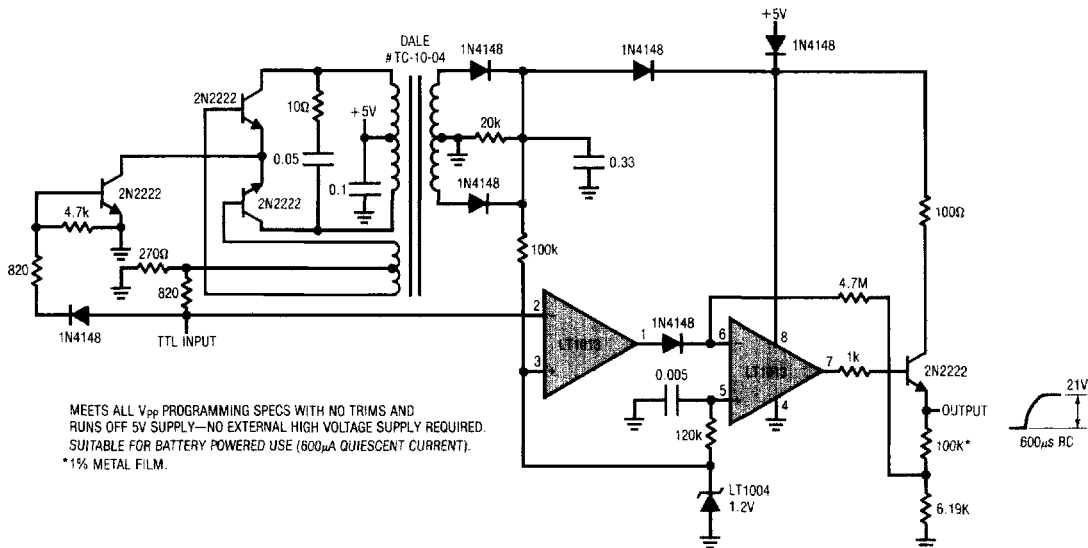

TYPICAL APPLICATIONS

Methane Concentration Detector with Linearized Output

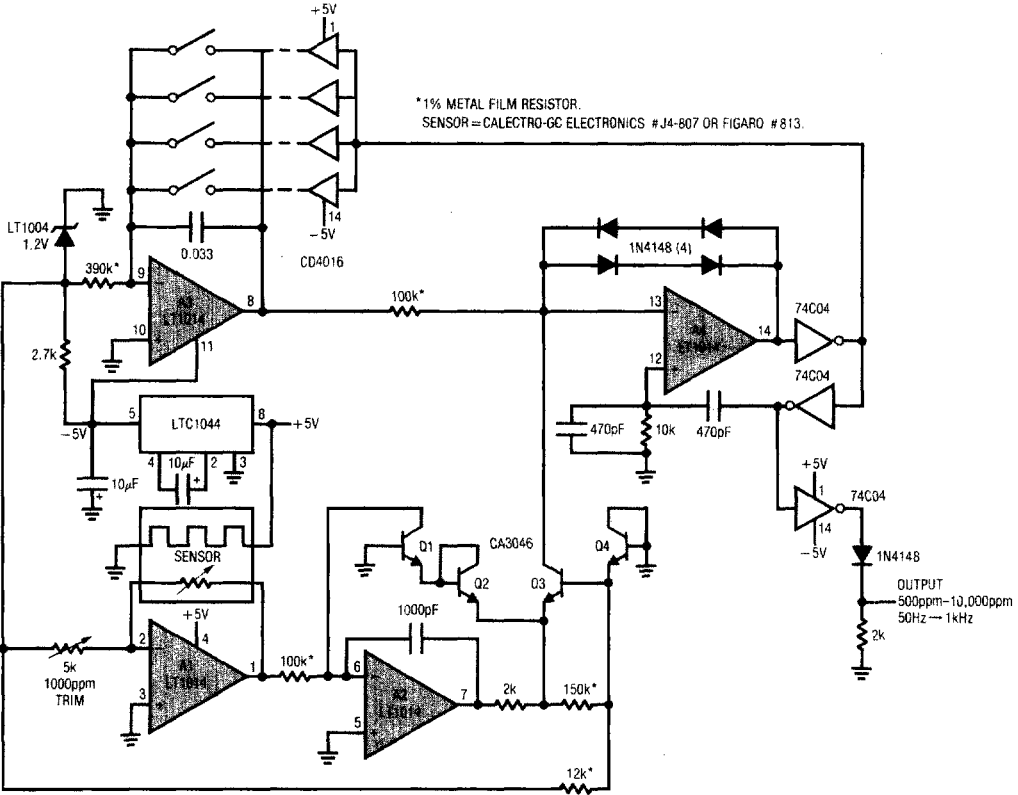

2

Low Power 9V to 5V Converter

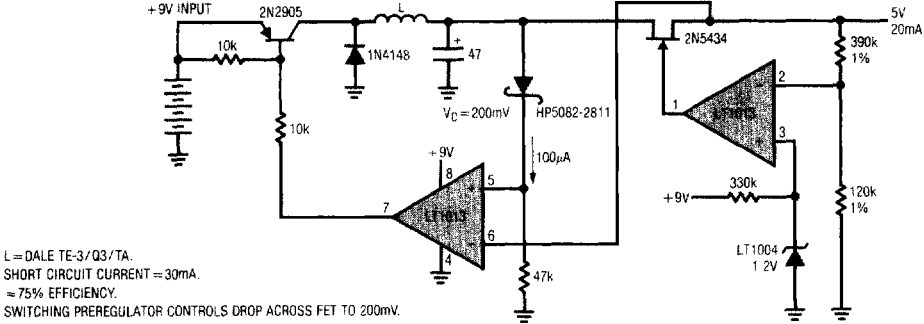

TYPICAL APPLICATIONS

5V Powered 4mA-20mA Current Loop Transmitter †

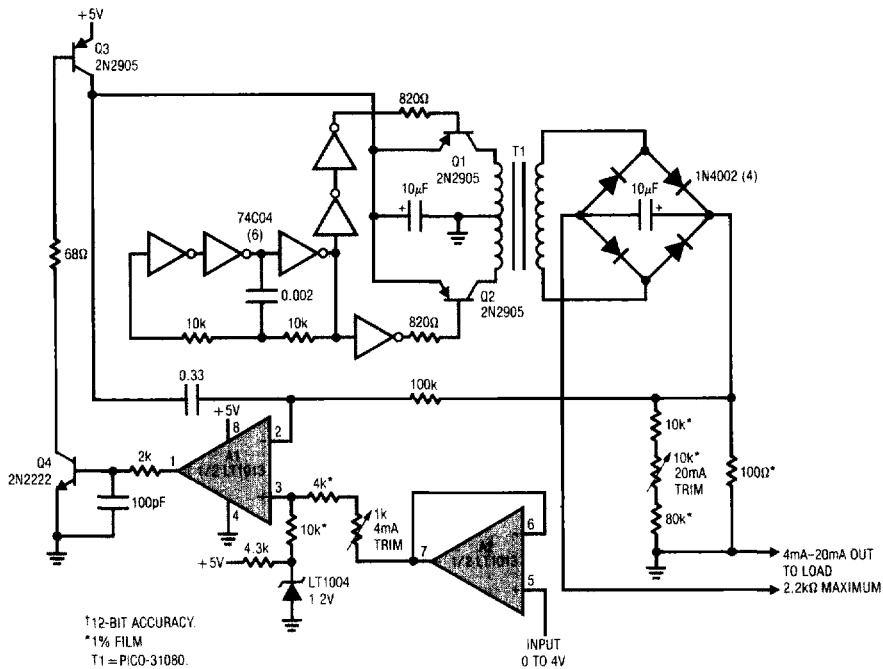

Fully Floating Modification to 4mA-20mA Current Loop †

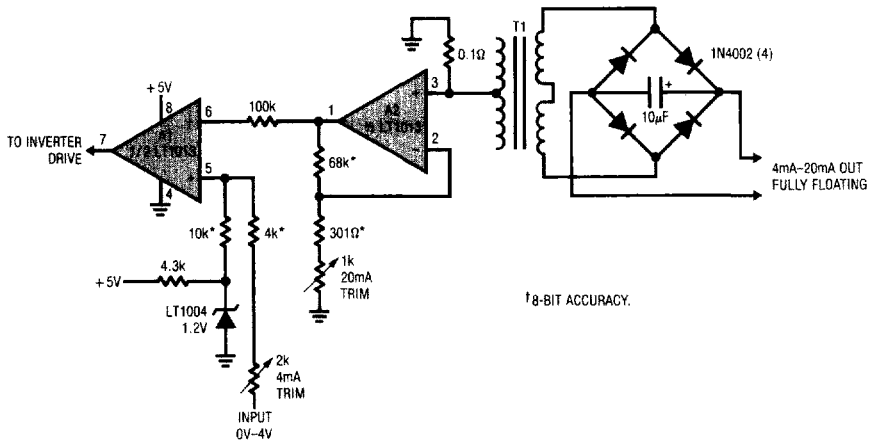

TYPICAL APPLICATIONS

5V Powered, Linearized Platinum RTD Signal Conditioner

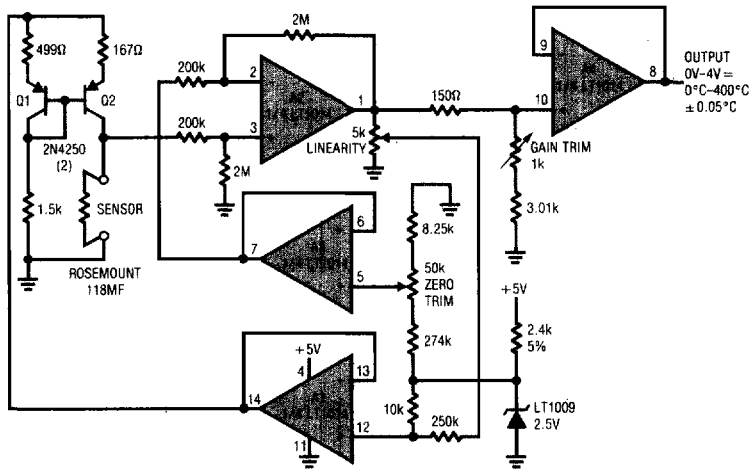

2

ALL RESISTORS ARE TRW-MAR-6 METAL FILM.
 RATIO MATCH 2M-200k ± 0.01%.
 TRIM SEQUENCE:
 SET SENSOR TO 0° VALUE
 ADJUST ZERO FOR 0V OUT.
 SET SENSOR TO 100° VALUE.
 ADJUST GAIN FOR 1.000V OUT.
 SET SENSOR TO 400°
 ADJUST LINEARITY FOR 4.000V OUT. REPEAT AS REQUIRED.

Strain Gage Bridge Signal Conditioner

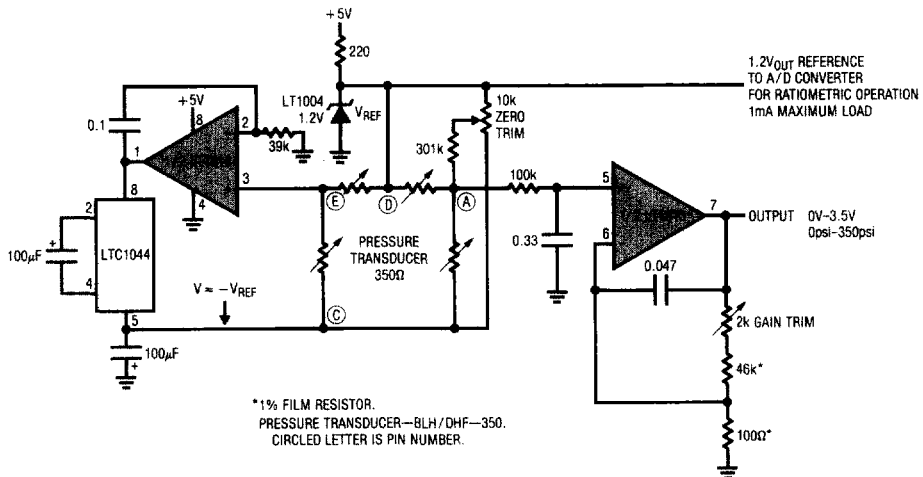

*1% FILM RESISTOR.
 PRESSURE TRANSDUCER—BLH/DHF—350.
 CIRCLED LETTER IS PIN NUMBER.

TYPICAL APPLICATIONS

LVDT Signal Conditioner

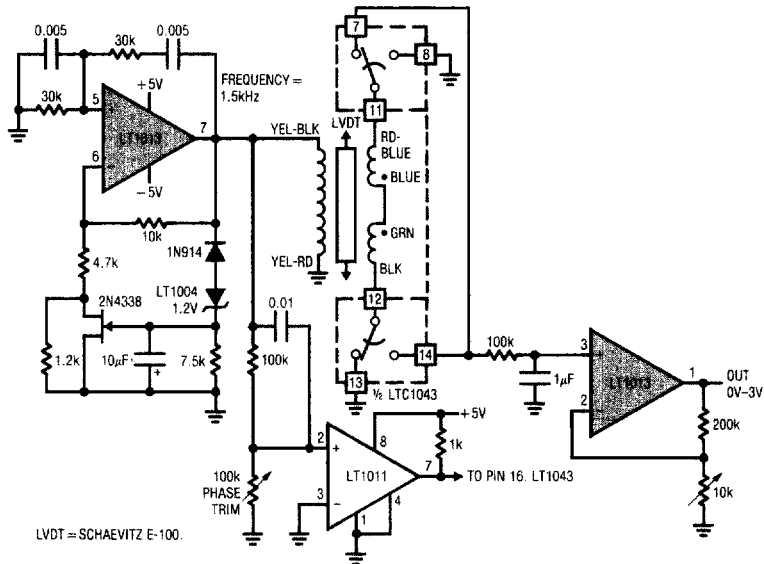

Triple Op Amp Instrumentation Amplifier with Bias Current Cancellation

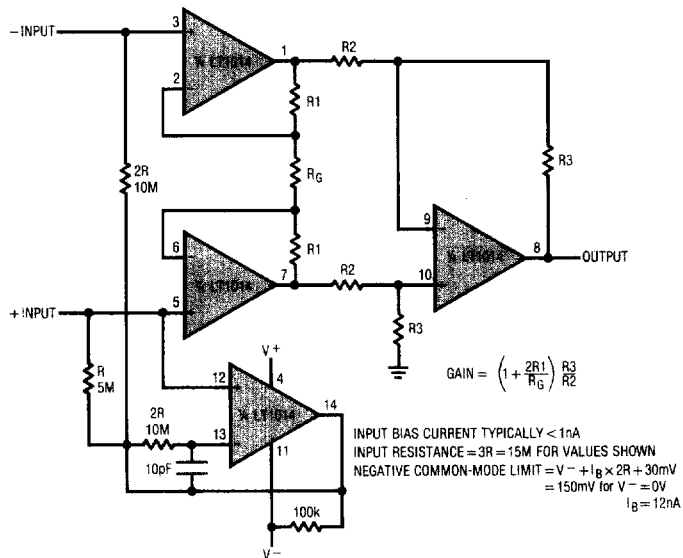

TYPICAL APPLICATIONS

Low Dropout Regulator for 6V Battery

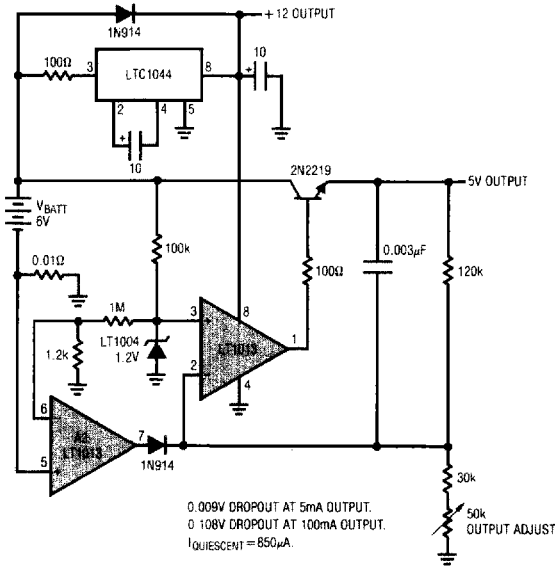

Voltage Controlled Current Source with Ground Referred Input and Output

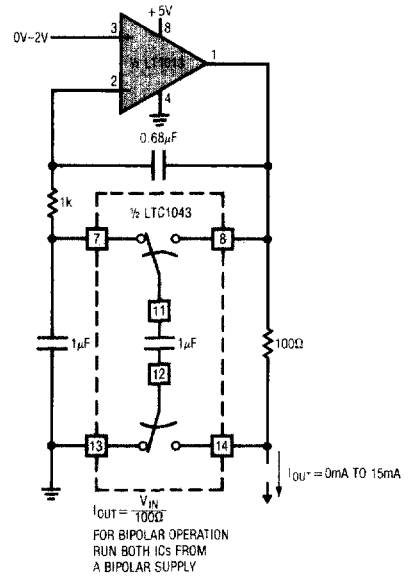

2

6V to ±15V Regulating Converter

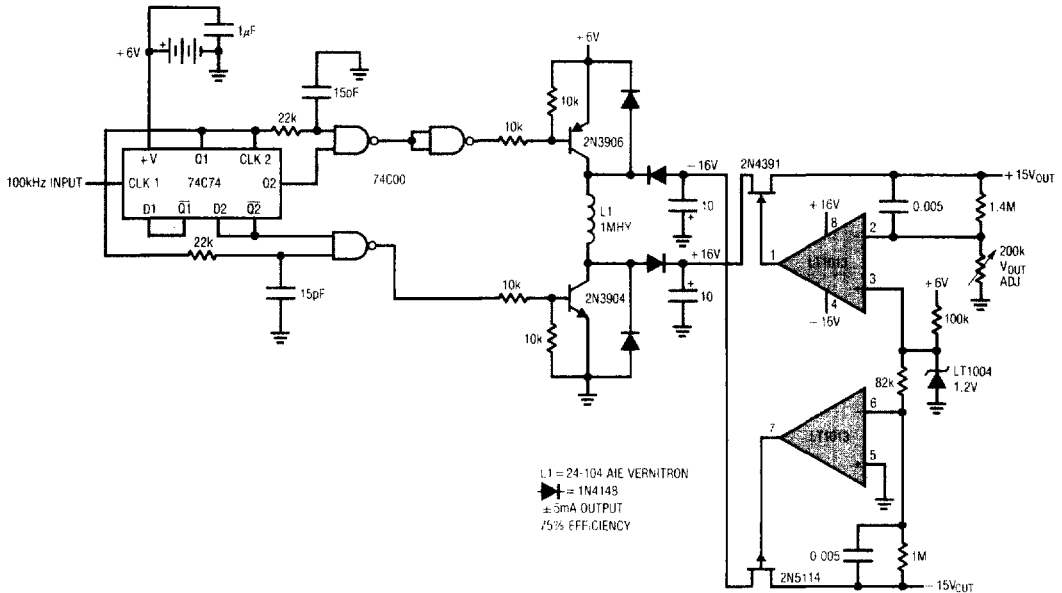

TYPICAL APPLICATIONS

Low Power, 5V Driven, Temperature Compensated Crystal Oscillator (TXCO)†

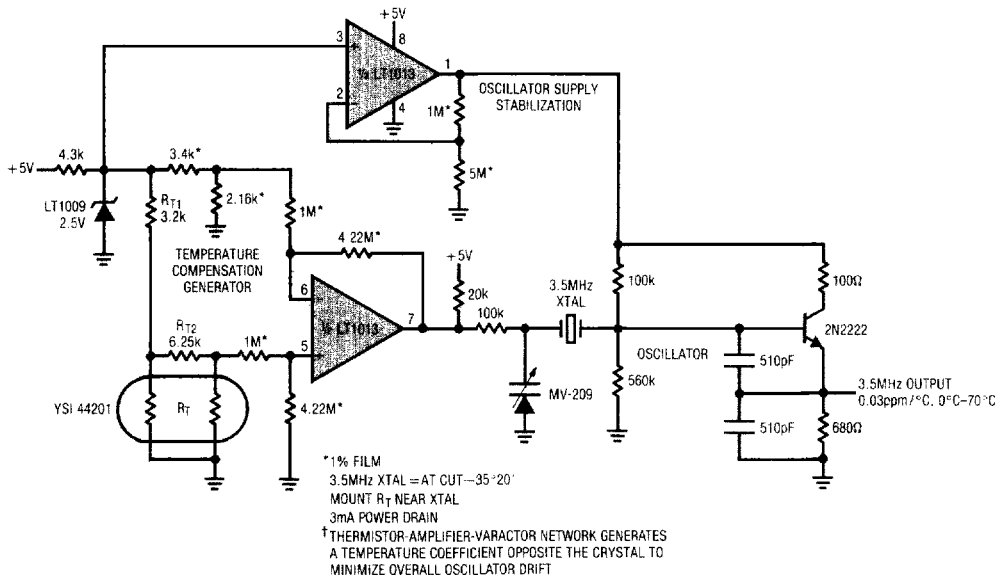

Step-Up Switching Regulator for 6V Battery

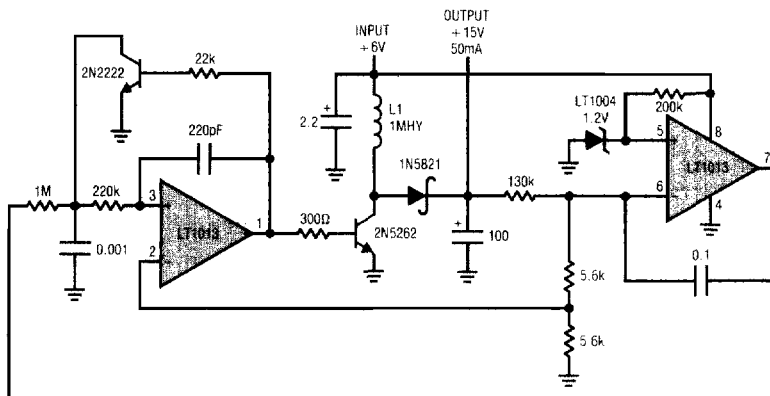

L1 = AIE—VERNITRON 24—104
 78% EFFICIENCY

SCHEMATIC DIAGRAM

1/2 LT1013, 1/4 LT1014

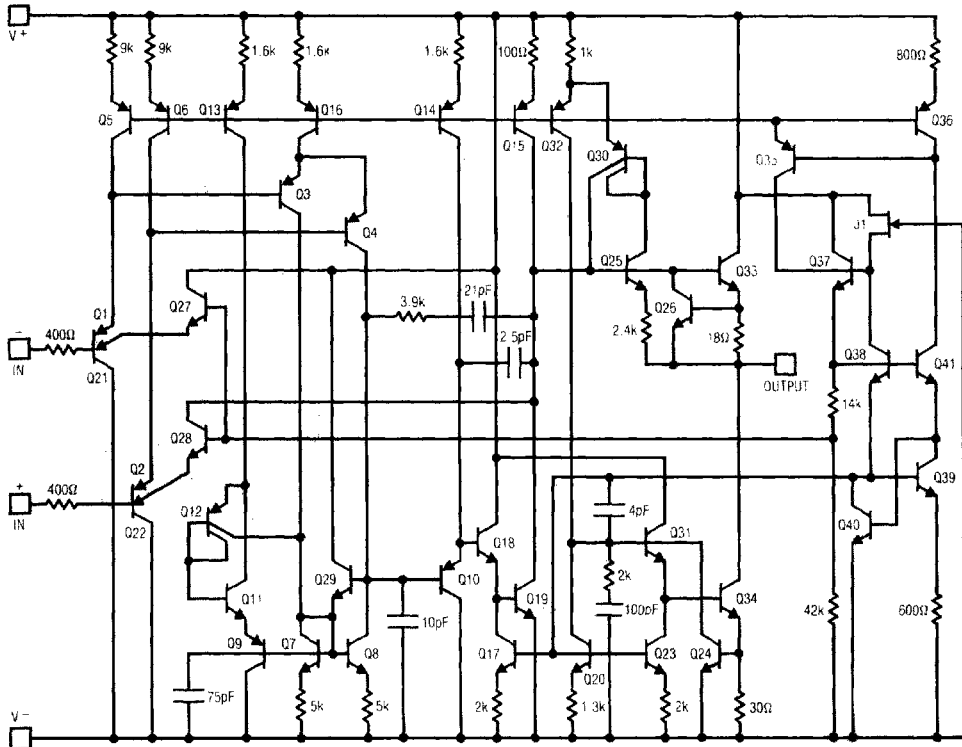

2