

- QP26LS31 – Quad High Speed Differential Line Driver**
QP26LS32 – Quad Differential Line Receiver
(200mv input sensitivity over $\pm 7V$ input range)
QP26LS33 – Quad Differential Line Receiver
(500mv input sensitivity over $\pm 15V$ input range)

General Description

The QP26LSxx family of interface products were re-engineered in a modern wafer fabrication process to replace AMD 26LSxx devices. All features of the AMD devices were duplicated; the devices are “plug and play” compatible. The circuit design and wafer fab process selected duplicates the electrical characteristics of the original devices, including parasitic performance. “Failsafe” characteristics were duplicated for the line receivers.

The QP26LSxx family is designed to meet the requirements of RS-422, RS-423, Federal Standards 1020 and 1030 for balanced and unbalanced digital data transmission.

The QP26LS31 is designed to provide unipolar differential drive to twisted-pair or parallel-wire transmission lines. The device provides both enable and disable functions common to all four drivers. It features tri-state outputs and logical OR-ed complementary enable inputs. The inputs are all LS compatible and are all one unit load.

The QP26LS32 features an input sensitivity of 200mV over the input voltage range of $\pm 7V$ while the QP26LS33 features an input sensitivity of 500mV over the input voltage range of $\pm 15V$. Both provide an enable and disable function common to all four receivers. Both feature tri-state outputs with 8mA sink capability and incorporate a fail-safe input-output relationship that keeps the outputs high when the inputs are open.

The family is constructed using Advanced Low-Power Schottky processing.

QP Semiconductor products are not authorized for use in any space applications. The inclusion of QP Semiconductor products in space applications implies that the space application manufacturer assumes all risk of such use and in doing so indemnifies QP Semiconductor against all charges.

Block Diagrams

QP26LS31

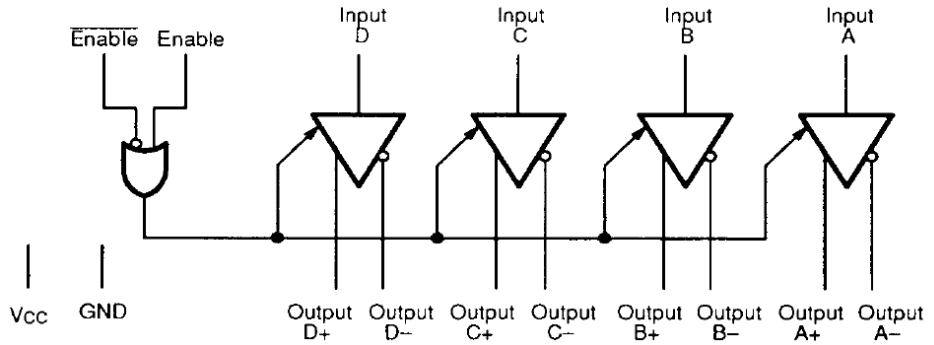

QP26LS32
QP26LS33

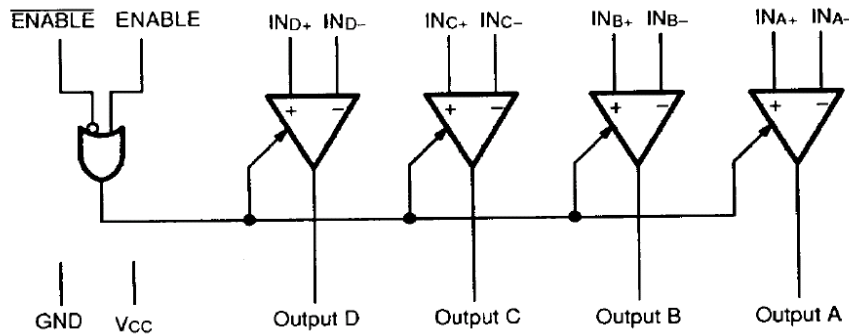

Connection Diagrams

QP26LS31

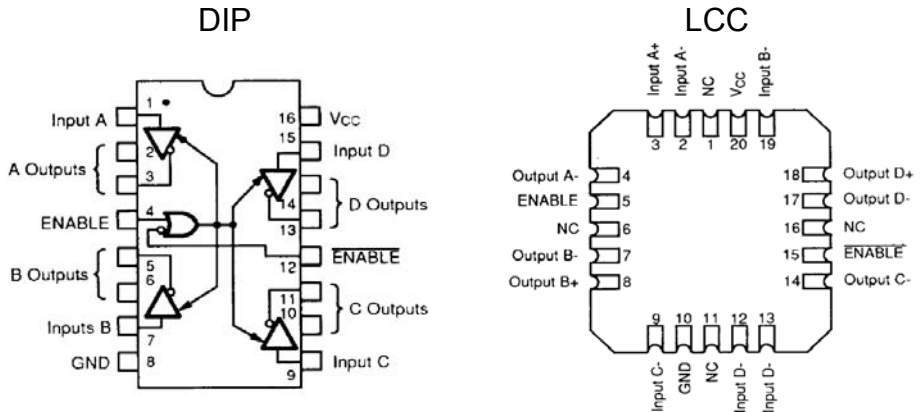

QP26LS32
QP26LS33

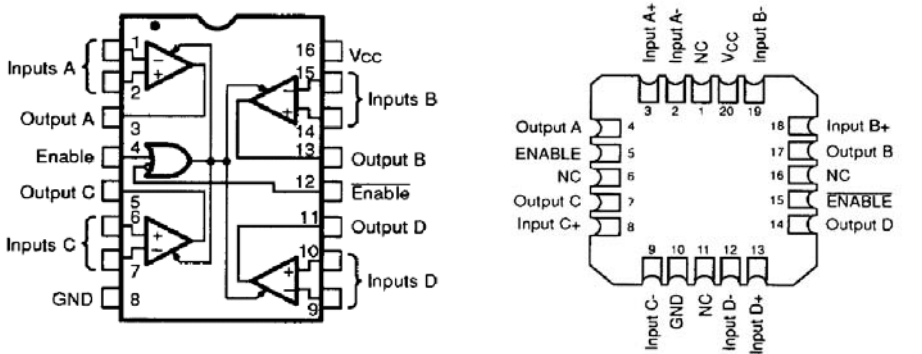

Absolute Maximum Ratings

Stresses above the AMR may cause permanent damage, extended operation at AMR may degrade performance and affect reliability

Condition	Units	Notes
26LS31		

QP26LS31, QP26LS32 & QP26LS33

Power Supply and Input Voltage	7.0	Volts DC
Output Voltage	5.5	Volts DC
Storage Temperature Range	-65 to +150	°C
Lead Temperature (soldering, 10 seconds)	+300	°C
Maximum Power Dissipation (P _D)	450	mW
Junction Temperature (T _J)	+150	°C

26LS32 and 26LS33		
Power Supply Voltage (V _{CC})	7.0	Volts DC
Common Mode Range	±25	Volts DC
Differential Input Voltage	±25	Volts DC
Enable Voltage	7.0	Volts DC
Output Sink Current	50	mA
Storage Temperature Range	-65 to +150	°C
Power Dissipation (P _D)	500	mW
Lead Temperature (soldering, 10 seconds)	+300	°C
Junction Temperature (T _J)	+150	°C

Recommended Operating Conditions			
Condition		Units	Notes
26LS31			
Supply Voltage Range (V _{CC})	4.5 to 5.5	Volts DC	
Minimum High-Level Input Voltage (V _{IH})	2.0	Volts DC	
Maximum Low-Level Input Voltage (V _{IL})	0.8	Volts DC	
Ambient Operating Range (T _A)	-55C to +125	°C	/1
26LS32 and 26LS33			
Supply Voltage Range (V _{CC})	4.5 to 5.5	Volts DC	
Minimum High-Level Input Voltage (V _{IH})	2.0	Volts DC	
Maximum Low-Level Input Voltage (V _{IL})	0.8	Volts DC	
Ambient Operating Range (T _A)	-55C to +125	°C	/1
Input Hysteresis (V _{HYST})	50	mV Typical	
/1 – Maximum PD, Maximum T _J Are Not to Be Exceeded			

TABLE I – ELECTRICAL PERFORMANCE CHARACTERISTICS					
Test	Symbol	Conditions -55°C ≤ T _A ≤ +125°C Unless Otherwise Specified	Min	Max	Unit
26LS31					
Output High Voltage	V _{OH}	V _{CC} = 4.5V, I _{OH} = -20mA	2.5		V
Output Low Voltage	V _{OL}	V _{CC} = 4.5V, I _{OH} = 20mA		0.5	V
Input High Voltage	V _{IH}	V _{CC} = 4.5V	2.0		V
Input Low Voltage	V _{IL}	V _{CC} = 5.5V		0.8	V
Input Low Current	I _{IL}	V _{CC} = 5.5V, V _{IN} = 0.4V	0.10	-0.36	mA

TABLE I – ELECTRICAL PERFORMANCE CHARACTERISTICS

Test	Symbol	Conditions -55°C ≤ TA ≤ +125°C Unless Otherwise Specified	Min	Max	Unit
Input High Current	I _{IH}	V _{CC} = 5.5V, V _{IN} = 2.7V	-2.0	20	μA
Input Reverse Current	I _I	V _{CC} = 5.5V, V _{IN} = 7.0V	-0.01	0.1	mA
Off-State (high impedance) Output Current	I _O	V _{CC} = 5.5V, V _O = 2.5V V _{CC} = 5.5V, V _O = 0.5V		20 -20	μA μA
Input Clamp Voltage	V _I	V _{CC} = 4.5V, I _{IN} = -18mA		-1.5	V
Output Short Circuit Current	I _{OS}	V _{CC} = 5.5V	-30	-150	mA
Power Supply Current	I _{CC}	V _{CC} = 5.5V All outputs disabled		80	mA
Propagation Delay, Output to Output	t _{SKREW}	V _{CC} = 5.0V 25°C C _L = 30pf -55 & 125°C		6.0 9.0	ns ns
Propagation Delay, Input to Output	t _{PLH} t _{PHL}	V _{CC} = 5.0V 25°C C _L = 30pf -55 & 125°C V _{CC} = 5.0V 25°C C _L = 30pf -55 & 125°C		20 30 20 30	ns ns ns ns
Output Disable Time, ENABLE to OUTPUT	t _{PLZ} t _{PHL}	V _{CC} = 5.0V 25°C C _L = 30pf -55 & 125°C V _{CC} = 5.0V 25°C C _L = 30pf -55 & 125°C		35 53 30 45	ns ns ns ns
Output Enable Time, ENABLE to OUTPUT	t _{PZL} t _{PZH}	V _{CC} = 5.0V 25°C C _L = 30pf -55 & 125°C V _{CC} = 5.0V 25°C C _L = 30pf -55 & 125°C		45 68 40 60	ns ns ns ns
26LS32 and 26LS33					
Differential Input Voltage Sensitivity	V _{TH}	V _{OUT} = V _{OL} or V _{OH} 26LS32 -7V ≤ V _{CM} ≤ +7V 26LS33 -15V ≤ V _{CM} ≤ +15V	-0.2 -0.5	+0.2 +0.5	V V
Input Resistance	R _{IN}	-15V ≤ V _{CM} ≤ +15V (one input ac ground)	6.0		kΩ
Input Current (under test)	I _{IN}	V _{IN} = +15V (other input -15V ≤ V _{IN} ≤ +15V)		2.3	mA
Output High Voltage	V _{OH}	V _{CC} = 4.5V, ΔV _{IN} = 1.0V, V _{ENABLEBAR} = 0.8V, I _{OH} = -440μA	2.5		V
Output Low Voltage	V _{OL}	V _{CC} = 4.5V, ΔV _{IN} = -1.0V, V _{ENABLEBAR} = 0.8V, I _{OL} = 4mA V _{CC} = 4.5V, ΔV _{IN} = -1.0V, V _{ENABLEBAR} = 0.8V, I _{OL} = 8mA		0.4 0.45	V V
Enable Low Voltage	V _{IL}	V _{CC} = 5.5V		0.8	V
Enable High Voltage	V _{IH}	V _{CC} = 4.5V	2.0		V
Enable Clamp Voltage	V _{IC}	V _{CC} = 4.5V, I _{IN} = -18mA V _{CC} = 5.5V		-1.5V	V

TABLE I – ELECTRICAL PERFORMANCE CHARACTERISTICS

Test	Symbol	Conditions -55°C ≤ TA ≤ +125°C Unless Otherwise Specified	Min	Max	Unit
Off-State (high impedance) Output Current	I _O	V _{CC} = 5.5V, V _O = 2.4V V _{CC} = 5.5V, V _O = 0.4V		20 -20	μA μA
Enable Low Current	I _{IL}	V _{IN} = 0.4V, V _{CC} = 5.5V		-0.36	mA
Enable High Current Sensitivity	I _{IH}	V _{IN} = 2.7V, V _{CC} = 5.5V		20	μA
Output Short Circuit Current	I _{OS}	V _O = 0V, V _{CC} = 5.5V, , ΔV _{IN} = 1.0V	-15	-85	mA
Supply Current	I _{CC}	V _{CC} = 5.5V, Data Inputs = GND, Outputs Disabled		70	mA
Enable Input High Current	I _I	V _{IN} = 5.5, V _{CC} = 5.5V		100	μA
Propagation Delay Input to Output	T _{PLH} T _{PHL}	V _{CC} = 5.0V, C _L = 15pF 25°C -55°C and 125°C 25°C -55°C and 125°C		25 38 25 38	ns ns ns ns
Output Disable Time, ENABLE to Output	T _{PLZ} T _{PHZ}	V _{CC} = 5.0V, C _L = 15pF 25°C -55°C and 125°C 25°C -55°C and 125°C		30 45 22 33	ns ns ns ns
Output Enable Time, Enable to Output	T _{PZL} T _{PZH}	V _{CC} = 5.0V, C _L = 15pF 25°C -55°C and 125°C 25°C -55°C and 125°C		22 33 22 33	ns ns ns ns

Ordering Information

Military Part Number	Package (Mil-Std-1835)	Generic
5962-7802301M2A	CQCC1-N20	26LS31
5962-7802301MEA	GDIP1-T16 CDIP2-T16	26LS31
5962-7802301MFA	GDIP2-F16 CDFP3-F16	26LS31
5962-7802301Q2A	CQCC1-N20	26LS31
5962-7802001M2A	CQCC1-N20	26LS32
5962-7802001MEA	GDIP1-T16 CDIP2-T16	26LS32
5962-7802001MFA	GDIP2-F16 CDFP3-F16	26LS32
5962-7802002M2A	CQCC1-N20	26LS33
5962-7802002MEA	GDIP1-T16 CDIP2-T16	26LS33
5962-7802002MFA	GDIP2-F16 CDFP3-F16	26LS33

QP Semiconductor supports Source Control Drawing (SCD), die sales and custom package development for this product family.

Notes:

QP26LS31, QP26LS32 & QP26LS33

This datasheet is informational only, these devices are manufactured to the requirements of the listed Standard Microcircuit Drawings (SMD's or 5962 drawings) and/or JAN Slash Sheets (M38510).

Package outline information and specifications are defined by the listed SMD or JAN drawing and are normally cross referenced in those drawings to Mil-Std-1835 package dimension requirements.

The listed drawings, Mil-PRF-38535, Mil-Std-883 and Mil-Std-1835 are available online at <http://www.dsccl.dla.mil/>

Additional information is available at our website <http://www.qpsemi.com>