

SN54ABT16833, SN74ABT16833 DUAL 8-BIT TO 9-BIT PARITY BUS TRANSCEIVERS

SCBS097D – FEBRUARY 1991 – REVISED JANUARY 1997

- Members of the Texas Instruments *Widebus™* Family
- State-of-the-Art *EPIC-II B™* BiCMOS Design Significantly Reduces Power Dissipation
- Latch-Up Performance Exceeds 500 mA Per JEDEC Standard JESD-17
- Typical V_{OLP} (Output Ground Bounce) < 1 V at $V_{CC} = 5$ V, $T_A = 25^\circ\text{C}$
- Distributed V_{CC} and GND Pin Configuration Minimizes High-Speed Switching Noise
- Flow-Through Architecture Optimizes PCB Layout
- High-Drive Outputs ($-32\text{-mA } I_{OH}$, $64\text{-mA } I_{OL}$)
- Parity-Error Flag With Parity Generator/Checker
- Register for Storage of Parity-Error Flag
- Package Options Include Plastic 300-mil Shrink Small-Outline (DL) and Thin Shrink Small-Outline (DGG) Packages and 380-mil Fine-Pitch Ceramic Flat (WD) Package Using 25-mil Center-to-Center Spacings

SN54ABT16833 . . . WD PACKAGE
SN74ABT16833 . . . DGG OR DL PACKAGE
(TOP VIEW)

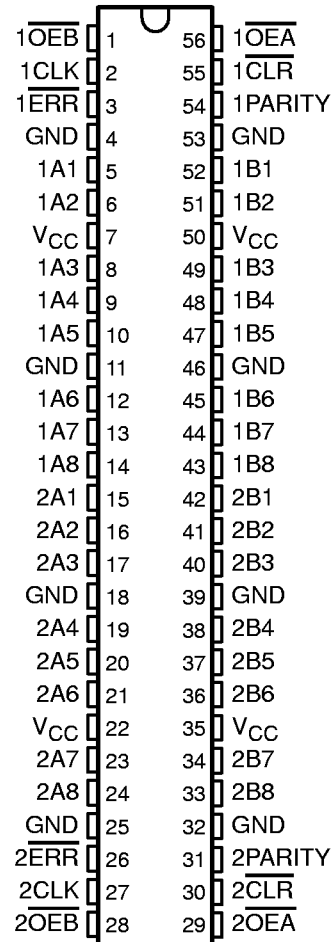

description

The 'ABT16833 consist of two noninverting 8-bit to 9-bit parity bus transceivers and are designed for communication between data buses. For each transceiver, when data is transmitted from the A bus to the B bus, an odd-parity bit is generated and output on the parity I/O pin (1PARITY or 2PARITY). When data is transmitted from the B bus to the A bus, 1PARITY (or 2PARITY) is configured as an input and combined with the B-input data to generate an active-low error flag if odd parity is not detected.

The error ($1\overline{ERR}$ or $2\overline{ERR}$) output is configured as an open-collector output. The B-to-A parity-error flag is clocked into $1\overline{ERR}$ (or $2\overline{ERR}$) on the low-to-high transition of the clock ($1\overline{CLK}$ or $2\overline{CLK}$) input. $1\overline{ERR}$ (or $2\overline{ERR}$) is cleared (set high) by taking the clear ($1\overline{CLR}$ or $2\overline{CLR}$) input low.

The output-enable ($\overline{OE}A$ and $\overline{OE}B$) inputs can be used to disable the device so that the buses are effectively isolated. When both $\overline{OE}A$ and $\overline{OE}B$ are low, data is transferred from the A bus to the B bus and inverted parity is generated. Inverted parity is a forced error condition that gives the designer more system diagnostic capability.

To ensure the high-impedance state during power up or power down, \overline{OE} should be tied to V_{CC} through a pullup resistor; the minimum value of the resistor is determined by the current-sinking capability of the driver.



Please be aware that an important notice concerning availability, standard warranty, and use in critical applications of Texas Instruments semiconductor products and disclaimers thereto appears at the end of this data sheet.

Widebus and EPIC-II B are trademarks of Texas Instruments Incorporated.

UNLESS OTHERWISE NOTED this document contains PRODUCTION DATA information current as of publication date. Products conform to specifications per the terms of Texas Instruments standard warranty. Production processing does not necessarily include testing of all parameters.

 **TEXAS
INSTRUMENTS**

Copyright © 1997, Texas Instruments Incorporated

SN54ABT16833, SN74ABT16833 DUAL 8-BIT TO 9-BIT PARITY BUS TRANSCEIVERS

SCBS097D – FEBRUARY 1991 – REVISED JANUARY 1997

description (continued)

The SN54ABT16833 is characterized for operation over the full military temperature range of -55°C to 125°C . The SN74ABT16833 is characterized for operation from -40°C to 85°C .

FUNCTION TABLE

INPUTS						OUTPUT AND I/O				FUNCTION
$\overline{\text{OEB}}$	$\overline{\text{OEA}}$	$\overline{\text{CLR}}$	CLK	Ai Σ OF H	Bi† Σ OF H	A	B	PARITY	$\overline{\text{ERR}}\ddagger$	
L	H	X	X	Odd Even	NA	NA	A	L H	NA	A data to B bus and generate parity
H	L	H	\uparrow	NA	Odd Even	B	NA	NA	H L	B data to A bus and check parity
X	X	L	X	X	X	X	NA	NA	H	Check error-flag register
H	H	H	No \uparrow	X	X _d Even	Z	Z	Z	NC	In this mode, $\overline{\text{ERR}}\S$ shows inverted parity of the A bus.
		L	No \uparrow	H						
		H	\uparrow	H						
L	L	X	X	Odd Even	NA	NA	A	H L	NA	A data to B bus and generate inverted parity

NA = not applicable, NC = no change, X = don't care

† Summation of high-level inputs includes PARITY along with Bi inputs.

‡ Output states shown assume $\overline{\text{ERR}}$ was previously high.

§ In this mode, $\overline{\text{ERR}}$ (when clocked) shows inverted parity of the A bus.



SN54ABT16833, SN74ABT16833 DUAL 8-BIT TO 9-BIT PARITY BUS TRANSCEIVERS

SCBS097D – FEBRUARY 1991 – REVISED JANUARY 1997

logic symbol†

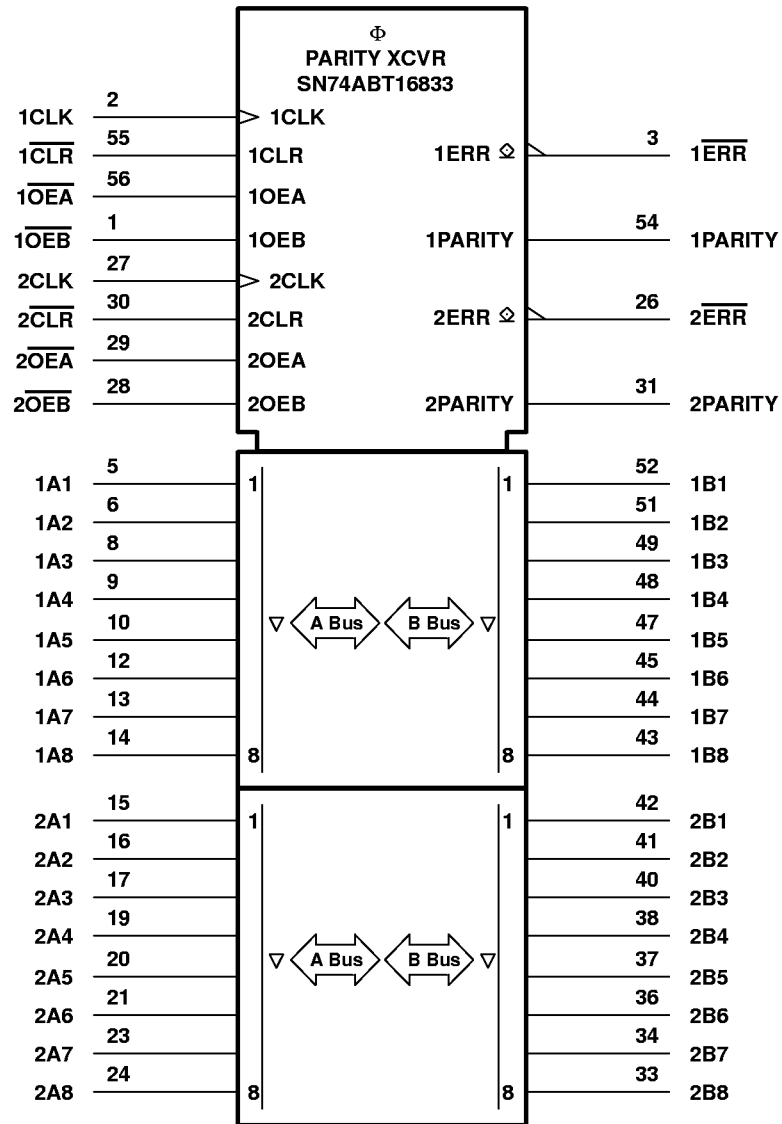

† This symbol is in accordance with ANSI/IEEE Std 91-1984 and IEC Publication 617-12.

SN54ABT16833, SN74ABT16833 DUAL 8-BIT TO 9-BIT PARITY BUS TRANSCEIVERS

SCBS097D – FEBRUARY 1991 – REVISED JANUARY 1997

logic diagram (positive logic)

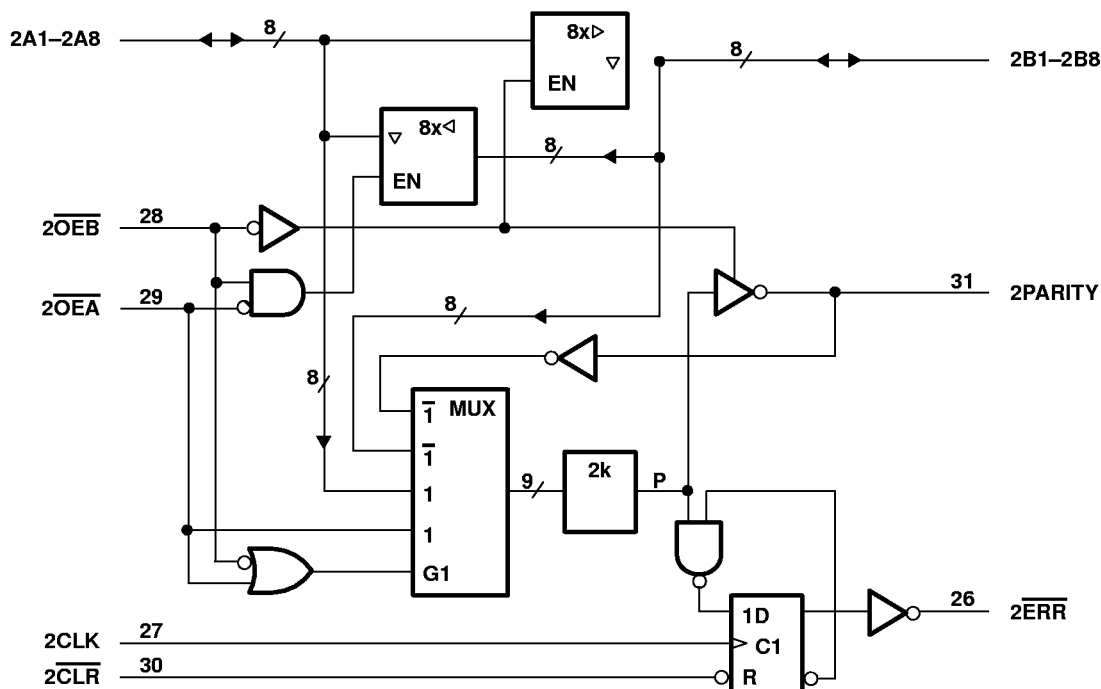
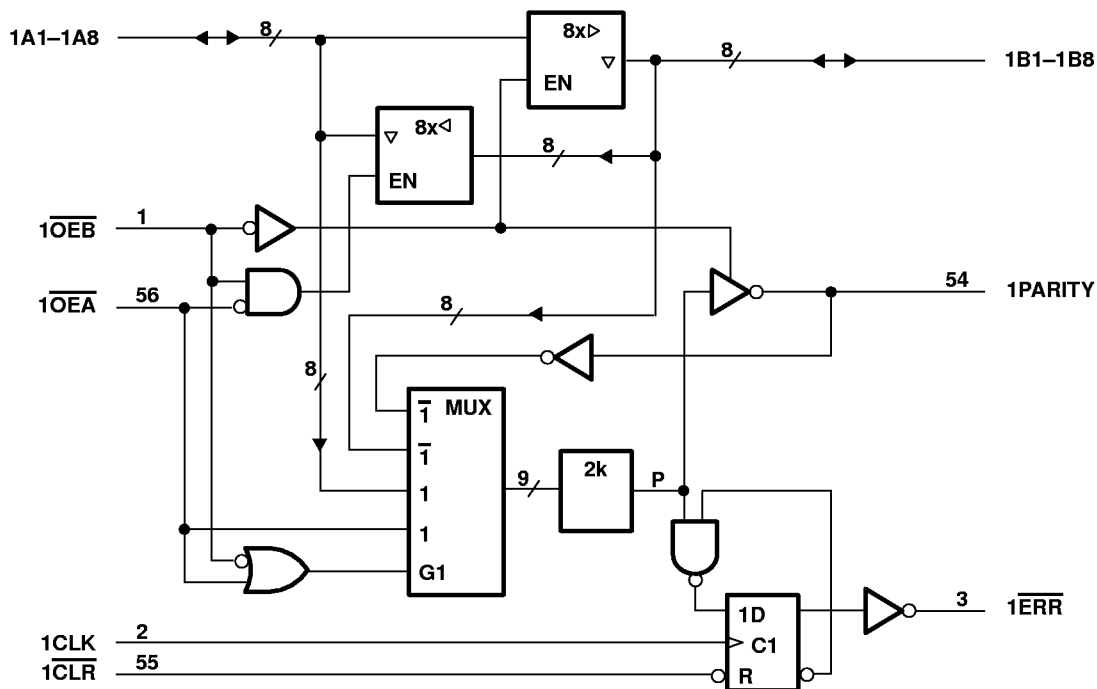

SN54ABT16833, SN74ABT16833 DUAL 8-BIT TO 9-BIT PARITY BUS TRANSCEIVERS

SCBS097D – FEBRUARY 1991 – REVISED JANUARY 1997

ERROR-FLAG FUNCTION TABLE

INPUTS		INTERNAL TO DEVICE	OUTPUT PRE-STATE	OUTPUT ERR	FUNCTION
$\overline{\text{CLR}}$	CLK	POINT P	$\overline{\text{ERR}}_{n-1} \dagger$		
H	\uparrow	H	H	H	Sample
H	\uparrow	X	L	L	
H	\uparrow	L	X	L	
L	X	X	X	H	Clear

\dagger State of $\overline{\text{ERR}}$ before changes at $\overline{\text{CLR}}$, CLK, or point P

error-flag waveforms

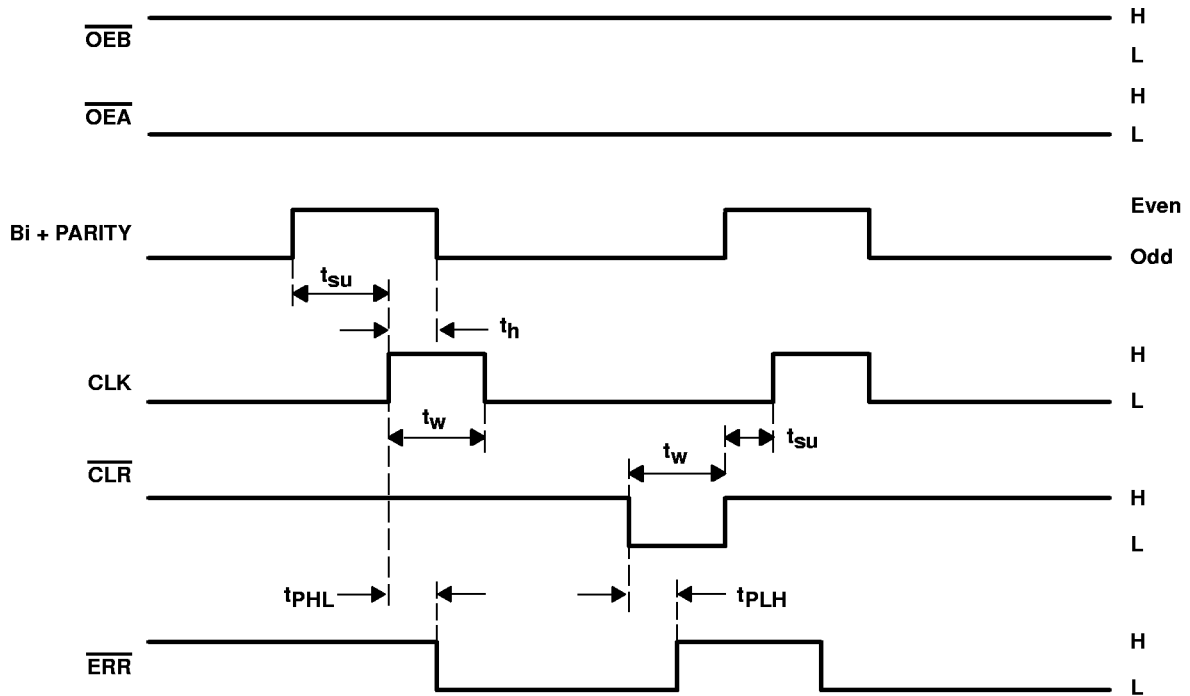

SN54ABT16833, SN74ABT16833 DUAL 8-BIT TO 9-BIT PARITY BUS TRANSCEIVERS

SCBS097D – FEBRUARY 1991 – REVISED JANUARY 1997

absolute maximum ratings over operating free-air temperature range (unless otherwise noted)†

Supply voltage range, V_{CC}	-0.5 V to 7 V
Input voltage range, V_I (except I/O ports) (see Note 1)	-0.5 V to 7 V
Voltage range applied to any output in the high or power-off state, V_O	-0.5 V to 5.5 V
Current into any output in the low state, I_O : SN54ABT16833	96 mA
SN74ABT16833	128 mA
Input clamp current, I_{IK} ($V_I < 0$)	-18 mA
Output clamp current, I_{OK} ($V_O < 0$)	-50 mA
Package thermal impedance, θ_{JA} (see Note 2): DGG package	81°C/W
DL package	74°C/W
Storage temperature range, T_{stg}	-65°C to 150°C

† Stresses beyond those listed under “absolute maximum ratings” may cause permanent damage to the device. These are stress ratings only, and functional operation of the device at these or any other conditions beyond those indicated under “recommended operating conditions” is not implied. Exposure to absolute-maximum-rated conditions for extended periods may affect device reliability.

- NOTES: 1. The input and output negative-voltage ratings may be exceeded if the input and output clamp-current ratings are observed.
2. The package thermal impedance is calculated in accordance with EIA/JEDEC Std JESD51.

recommended operating conditions (see Note 3)

	SN54ABT16833		SN74ABT16833		UNIT
	MIN	MAX	MIN	MAX	
V_{CC} Supply voltage	4.5	5.5	4.5	5.5	V
V_{IH} High-level input voltage	2		2		V
V_{IL} Low-level input voltage		0.8		0.8	V
V_I Input voltage	0	V_{CC}	0	V_{CC}	V
V_{OH} High-level output voltage		ERR		5.5	V
I_{OH} High-level output current		Except ERR		-24	mA
I_{OL} Low-level output current		48		64	mA
$\Delta t/\Delta v$ Input transition rise or fall rate		Outputs enabled		10	ns/V
T_A Operating free-air temperature	-55	125	-40	85	°C

NOTE 3: Unused pins (input or I/O) must be held high or low to prevent them from floating.

SN54ABT16833, SN74ABT16833 DUAL 8-BIT TO 9-BIT PARITY BUS TRANSCEIVERS

SCBS097D – FEBRUARY 1991 – REVISED JANUARY 1997

electrical characteristics over recommended operating free-air temperature range (unless otherwise noted)

PARAMETER		TEST CONDITIONS		T _A = 25°C			SN54ABT16833		SN74ABT16833		UNIT
				MIN	TYP†	MAX	MIN	MAX	MIN	MAX	
V _{IK}		V _{CC} = 4.5 V, I _I = -18 mA		-1.2			-1.2		-1.2		V
V _{OH}	All outputs except $\overline{\text{ERR}}$	V _{CC} = 4.5 V, I _{OH} = -3 mA		2.5	3		2.5			V	
		V _{CC} = 5 V, I _{OH} = -3 mA		3	3.4		3		3		
		V _{CC} = 4.5 V		I _{OH} = -24 mA				2			
				I _{OH} = -32 mA		2*	2.7			2	
V _{OL}		V _{CC} = 4.5 V		I _{OL} = 24 mA		0.25	0.55	0.55			
				I _{OL} = 64 mA		0.3	0.55*			0.55	
V _{hys}				100							mV
I _{OH}	$\overline{\text{ERR}}$	V _{CC} = 4.5 V, V _{OH} = 5.5 V		20			20		20		μA
I _{off}		V _{CC} = 0, V _I or V _O ≤ 4.5 V		±100					±100		μA
I _{CEX}	Outputs high	V _{CC} = 5.5 V, V _O = 5.5 V		50			50		50		μA
I _I	Control inputs	V _{CC} = 5.5 V, V _I = V _{CC} or GND		±1			±1		±1		μA
	A or B ports			±100			±100		±100		
I _{IL}	A or B ports	V _{CC} = 0, V _I = GND		-50			-50		-50		μA
I _O ‡		V _{CC} = 5.5 V, V _O = 2.5 V		-50	-100	-180	-50	-180	-50	-180	mA
I _{OZH} §		V _{CC} = 5.5 V, V _O = 2.7 V		50			50		50		μA
I _{OZL} §		V _{CC} = 5.5 V, V _O = 0.5 V		-50			-50		-50		μA
I _{CC}	A or B ports	V _{CC} = 5.5 V, I _O = 0, V _I = V _{CC} or GND		Outputs high		1.5	2	2		2	
				Outputs low		28	36	36		36	
				Outputs disabled		1	2	2		2	
ΔI _{CC} ¶		V _{CC} = 5.5 V, One input at 3.4 V, Other inputs at V _{CC} or GND		50			50		50		μA
C _i	Control inputs	V _I = 2.5 V or 0.5 V		3							pF
C _{io}	A or B ports	V _O = 2.5 V or 0.5 V		9							pF

* On products compliant to MIL-PRF-38535, this parameter does not apply.

† All typical values are at V_{CC} = 5 V.

‡ Not more than one output should be tested at a time, and the duration of the test should not exceed one second.

§ The parameters I_{OZH} and I_{OZL} include the input leakage current.

¶ This is the increase in supply current for each input that is at the specified TTL voltage level rather than V_{CC} or GND.

PRODUCT PREVIEW information concerns products in the formative or design phase of development. Characteristic data and other specifications are design goals. Texas Instruments reserves the right to change or discontinue these products without notice.



POST OFFICE BOX 655303 • DALLAS, TEXAS 75265

SN54ABT16833, SN74ABT16833 DUAL 8-BIT TO 9-BIT PARITY BUS TRANSCEIVERS

SCBS097D – FEBRUARY 1991 – REVISED JANUARY 1997

timing requirements over recommended ranges of supply voltage and operating free-air temperature (unless otherwise noted) (see Figure 1)

		$V_{CC} = 5\text{ V},$ $T_A = 25^\circ\text{C}$		SN54ABT16833		SN74ABT16833		UNIT
		MIN	MAX	MIN	MAX	MIN	MAX	
t_w	Pulse duration, CLK high or low	3		3		3		ns
t_{su}	Setup time before CLK \uparrow	A port	4.5		4.5		4.5	ns
		$\overline{\text{CLR}}$	1		1		1	
		$\overline{\text{OEA}}$	5		5		5	
t_h	Hold time after CLK \uparrow	0		0		0		ns

switching characteristics over recommended ranges of supply voltage and operating free-air temperature (unless otherwise noted) (see Figure 1)

PARAMETER	FROM (INPUT)	TO (OUTPUT)	$V_{CC} = 5\text{ V},$ $T_A = 25^\circ\text{C}$			SN54ABT16833		SN74ABT16833		UNIT
			MIN	TYP	MAX	MIN	MAX	MIN	MAX	
t_{PLH}	A or B	B or A	1.5	2.5	3.3	1.5	4.2	1.5	4.1	ns
t_{PHL}			2	3.1	3.9	2	4.5	2	4.3	
t_{PZH}	$\overline{\text{OE}}$	A or B	2	3.9	4.9	2	5.8	2	5.6	ns
t_{PZL}			2.5	4.3	5.1	2.5	6.2	2.5	6	
t_{PHZ}	$\overline{\text{OE}}$	A or B	2	3.6	4.5	2	5.5	2	5.4	ns
t_{PLZ}			1.5	3	3.8	1.5	4.7	1.5	4.3	
t_{PLH}	A or $\overline{\text{OE}}$	PARITY	2	4.6	5.4	2	7	2	6.7	ns
t_{PHL}			2	4.3	5.1	2	6.5	2	6.1	
t_{PZH}	$\overline{\text{OE}}$	PARITY	2	3.6	5	2	5.8	2	5.7	ns
t_{PZL}			2.5	4.4	5.8	2.5	6.7	2.5	6.5	
t_{PHZ}	$\overline{\text{OE}}$	PARITY	1.5	3.2	4	1.5	4.8	1.5	4.7	ns
t_{PLZ}			1.5	2.9	3.7	1.5	4.2	1.5	4.1	
t_{PLH}	CLK, $\overline{\text{CLR}}$	$\overline{\text{ERR}}$	2	3.4	4.2	2	4.8	2	4.6	ns
t_{PHL}	CLK		2	2.8	3.6	2	4.1	2	3.9	

PRODUCT PREVIEW information concerns products in the formative or design phase of development. Characteristic data and other specifications are design goals. Texas Instruments reserves the right to change or discontinue these products without notice.



POST OFFICE BOX 655303 • DALLAS, TEXAS 75265

PARAMETER MEASUREMENT INFORMATION

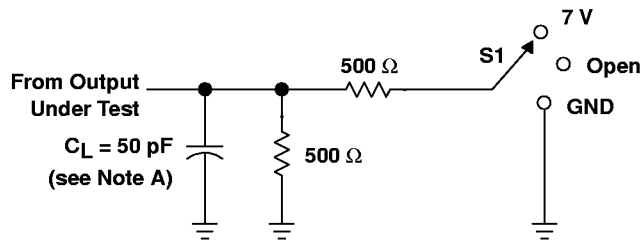

LOAD CIRCUIT

TEST	S1
t_{PLH}/t_{PHL}	Open
t_{PLZ}/t_{PZL}	7 V
t_{PHZ}/t_{PZH}	Open

$\overline{\text{ERR}}$	S1
t_{PHL} (see Note E)	7 V
t_{PLH} (see Note F)	7 V

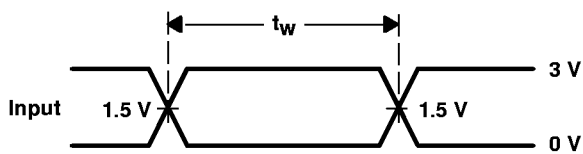

VOLTAGE WAVEFORMS
PULSE DURATION

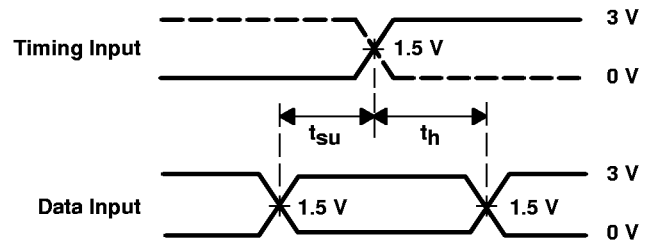

VOLTAGE WAVEFORMS
SETUP AND HOLD TIMES

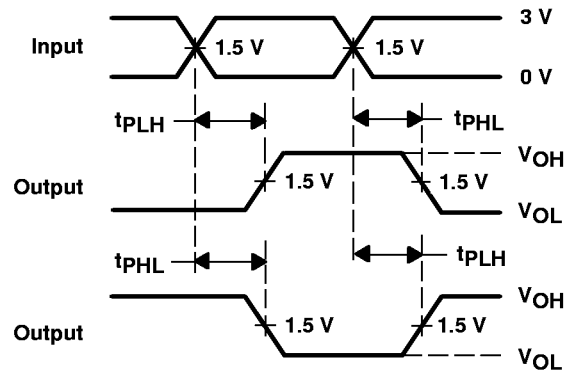

VOLTAGE WAVEFORMS
PROPAGATION DELAY TIMES
INVERTING AND NONINVERTING OUTPUTS

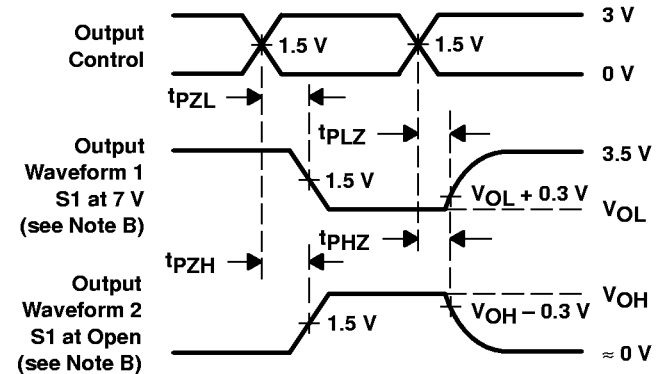

VOLTAGE WAVEFORMS
ENABLE AND DISABLE TIMES
LOW- AND HIGH-LEVEL ENABLING

- NOTES: A. C_L includes probe and jig capacitance.
 B. Waveform 1 is for an output with internal conditions such that the output is low except when disabled by the output control. Waveform 2 is for an output with internal conditions such that the output is high except when disabled by the output control.
 C. All input pulses are supplied by generators having the following characteristics: PRR \leq 10 MHz, $Z_O = 50 \Omega$, $t_r \leq 2.5$ ns, $t_f \leq 2.5$ ns.
 D. The outputs are measured one at a time with one transition per measurement.
 E. t_{PHL} is measured at 1.5 V.
 F. t_{PLH} is measured at $V_{OL} + 0.3$ V.

Figure 1. Load Circuit and Voltage Waveforms